



**THE CHALLENGE
OF THE
NEW OPTICAL FIBRE
TECHNOLOGIES**

**26th November 2002
Botanical Gardens
Birmingham**

The Way We Were
1GbE and 10GbE
OF Categories
Channel Design
Cleaning
SFF Connecting Hardware
Testing
FIA Support Documentation



THE CHALLENGE OF THE NEW OPTICAL FIBRE TECHNOLOGIES

Mike Gilmore, The Cabling Partnership

The Challenge of the New Optical Fibre Technologies

The Cabling Partnership

www.it-cabling.com

e-Ready Building

www.e-readybuilding.com

PO Box MT65, LEEDS, LS17 8YD, United Kingdom

Tel: +44 (0) 113 232 3721 Fax: +44 (0) 113 232 3724

Mike Gilmore, Senior Partner



Secretary: ISO/IEC JTC1 SC25 WG3: Generic Cabling
Member: ISO/IEC JTC1 SC25 Project Team: SOHO



Convenor (1994-2002): CENELEC TC215 WG1: IT Cabling



Chairman: BSI TCT7/-/1: IT Cabling
Chairman: BSI TCT7/-/3: IT Cabling Support Group
Technical and Standards Director, Fibreoptic Industry Association

mike.gilmore@btinternet.com



THE CHALLENGE OF THE NEW OPTICAL FIBRE TECHNOLOGIES

Mike Gilmore, The Cabling Partnership

The Way We Were

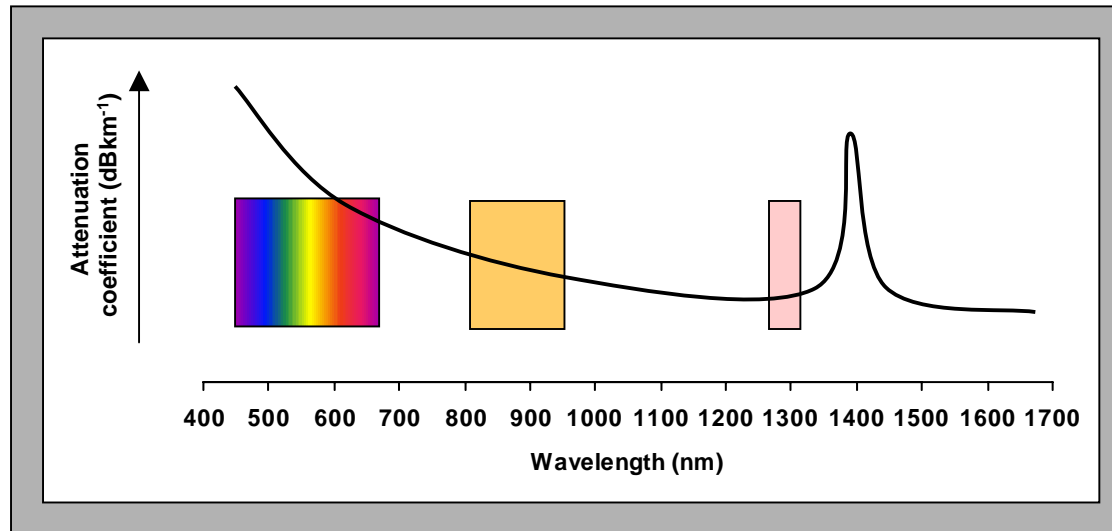

Mbs ⁻¹	Network name	62.5/125		50/125	
		OPB (dB)	L _{max} (m)	OPB (dB)	L _{max} (m)
	850 nm MMF				
10	ISO/IEC 8802-3: 10BASE-FL/FB	12.5	2000	6.8	1514
4/16	ISO/IEC TR 11802-4: 4 & 16 Mb/s Token Ring	13.0	2000	8.0	1857
	1300 nm MMF				
100	ISO/IEC 9314-3: FDDI PMD	11.0	2000	6.0	2000
100	ISO/IEC 8802-3: 100BASE-FX	11.0	2000	5.3	2000

62.5/125 seems to offer an advantage



THE CHALLENGE OF THE NEW OPTICAL FIBRE TECHNOLOGIES

Mike Gilmore, The Cabling Partnership

1 GbE Technologies

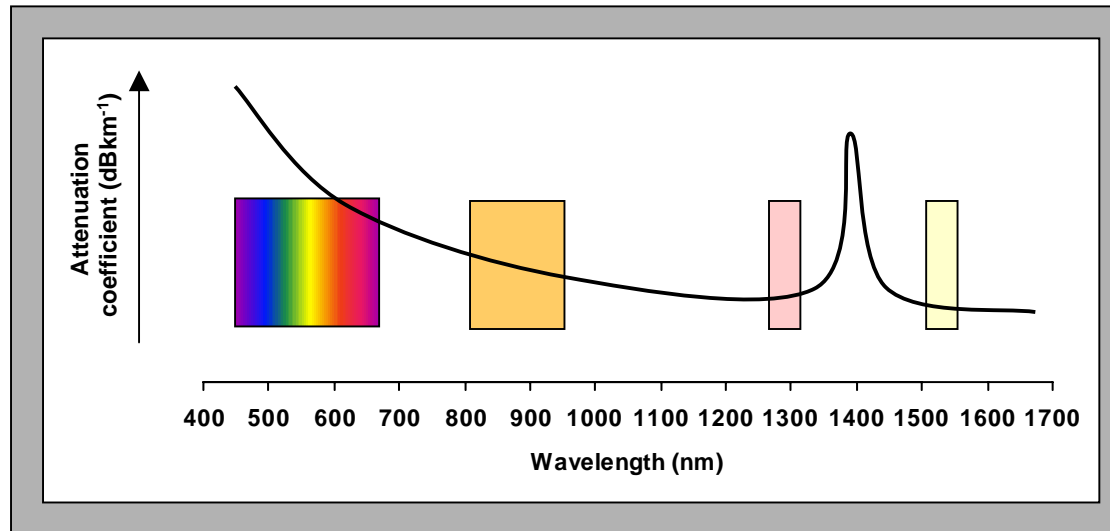

	850nm		1300nm		1310nm
	62.5/125	50/125	62.5/125	50/125	SMF
OFL Modal Bandwidth (MHz.km)	200	500	500	500	
Assumed OF attenuation (dBkm ⁻¹)	3.75	3.50	1.5	1.5	0.5
	1000BASE		-SX		-LX
			830nm	1270nm	
Maximum channel length (m)	275	550	550	550	5000
Max. OF cable attenuation (dB)	1.1	2.06	0.85	0.85	2.57
Connecting hardware allowance (dB)	1.5	1.5	1.5	1.5	2.0
Maximum Channel Insertion Loss (dB)	2.60	3.56	2.35	2.35	4.57



THE CHALLENGE OF THE NEW OPTICAL FIBRE TECHNOLOGIES Mike Gilmore, The Cabling Partnership

10 GbE Technologies

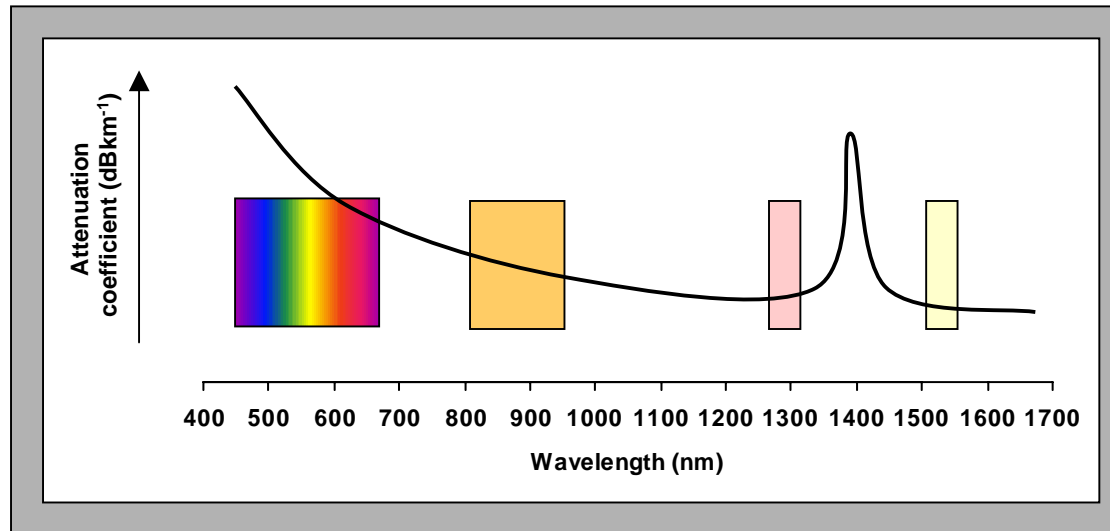

	850nm		1300nm	1310nm		1550nm
	62.5/125	50/125	MMF	SMF		
OFL Modal Bandwidth (MHz.km)	200	500	500			
Assumed OF attenuation (dBkm ⁻¹)	3.50	3.50	1.5	0.4		0.5
10GBASE	-SR/SW		-LX4	-LR/LW	-LX4	-ER/EW
	830nm		1269-1356 nm	1270nm	1269-1356 nm	1550nm
Maximum channel length (m)	33	82	300	10000	10000	40000
Max. OF cable attenuation (dB)	0.12	0.30	0.46	4.20	4.20	
Connecting hardware allowance (dB)	1.5	1.5	1.5	2	2	
Maximum Channel Insertion Loss (dB)	1.62	1.80	1.96	6.20	6.20	10.9



THE CHALLENGE OF THE NEW OPTICAL FIBRE TECHNOLOGIES Mike Gilmore, The Cabling Partnership

Optical Fibre Cable Categories

IT CABLING STANDARDS



ISO/IEC 11801 Ed. 2 (2002)
(to be published Q3, 2002)



EN 50173 Ed. 2 (2002)
(to be published Q3, 2002)

	Wavelength	Multimode OF			Wavelength	Singlemode OF
		50/125 or 62.5/125	OM2	OM3		
Attenuation coefficient (max)	850nm	3,5 dBkm ⁻¹			1310nm	1,0
	1300nm	1,5 dBkm ⁻¹			1550nm	1,0
Modal bandwidth OFL (MHz.km min)	850nm	200	500	1500		
	1300nm	500	500	500		
Modal bandwidth LL (MHz.km min)	850nm	-	-	2000		
	1300nm	-	-	-		
Propagation delay (ns.m ⁻¹ max)	850nm	5			1310nm	5
	1300nm					

Legacy OF

Legacy OF



THE CHALLENGE OF THE NEW OPTICAL FIBRE TECHNOLOGIES

Mike Gilmore, The Cabling Partnership

OM3 and 10GBASE-SR/SW

	62.5/125	50/125	50/125
	850nm		
	OM1	OM2	OM3
OFL Modal Bandwidth (MHz.km)	200	500	500
Assumed OF attenuation (dBkm ⁻¹)	3.50	3.50	3.50
10GBASE		-SR/SW	
	830nm		
Maximum channel length (m)	33	82	300
Max. OF cable attenuation (dB)	0.12	0.30	1.09
Connecting hardware allowance (dB)	1.5	1.5	1.5
Maximum Channel Insertion Loss (dB)	1.62	1.80	2.59



THE CHALLENGE OF THE NEW OPTICAL FIBRE TECHNOLOGIES

Mike Gilmore, The Cabling Partnership

“Mission-Critical” Infrastructures

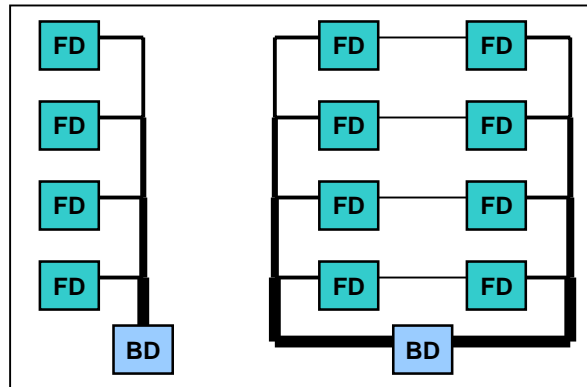
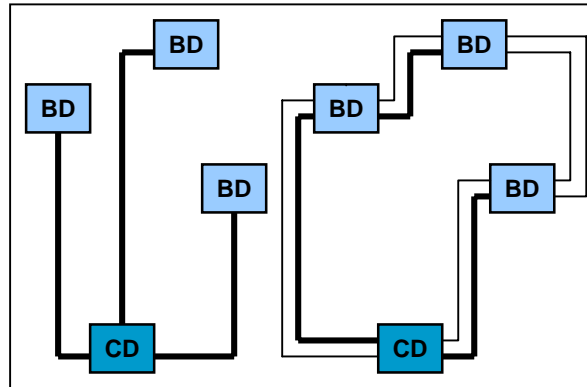



THE CHALLENGE OF THE NEW OPTICAL FIBRE TECHNOLOGIES

Mike Gilmore, The Cabling Partnership

Component Length Equivalence

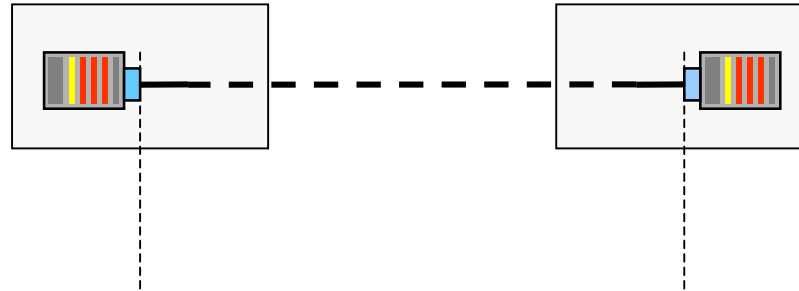

MMF COMPONENT EQUIVALENCE		
	@ 850nm	@ 1300nm
Cable	3.5 dBkm ⁻¹	1.5 dBkm ⁻¹
Connector	0.75 dB	0.75 dB
	214 m	500 m
Splice	0.30 dB	0.30 dB
	86 m	200 m

SMF COMPONENT EQUIVALENCE		
	@ 1310nm	@ 1550nm
Cable	1.0 dBkm ⁻¹	0.5 dBkm ⁻¹
Connector	0.75 dB	0.75 dB
	750 m	1500 m
Splice	0.30 dB	0.30 dB
	300 m	600 m



THE CHALLENGE OF THE NEW OPTICAL FIBRE TECHNOLOGIES

Mike Gilmore, The Cabling Partnership

Creative Diversity

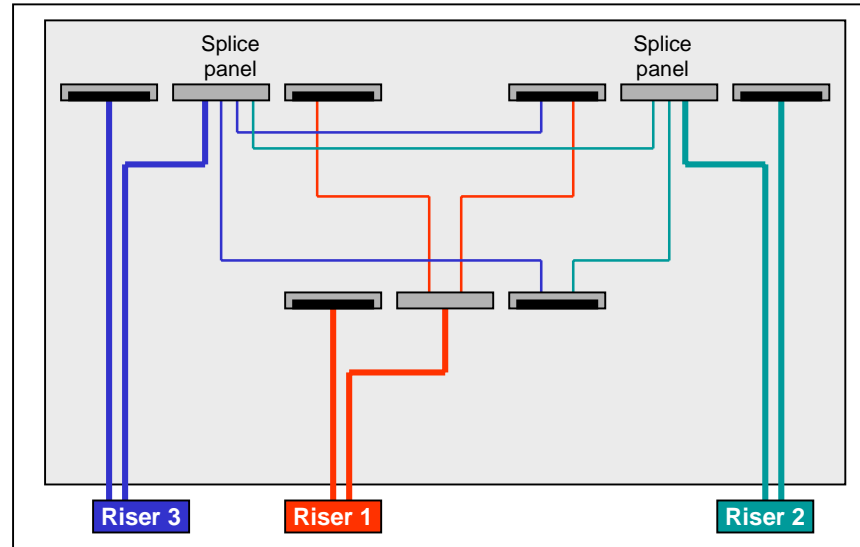



THE CHALLENGE OF THE NEW OPTICAL FIBRE TECHNOLOGIES

Mike Gilmore, The Cabling Partnership

Cleaning

Connector end-face Epoxy adhesive

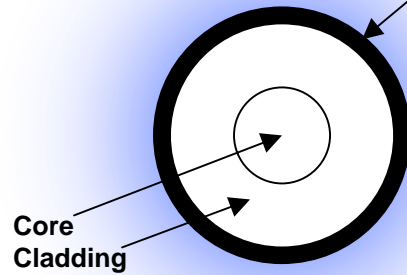

Contamination radius r_1
Contamination radius r_2

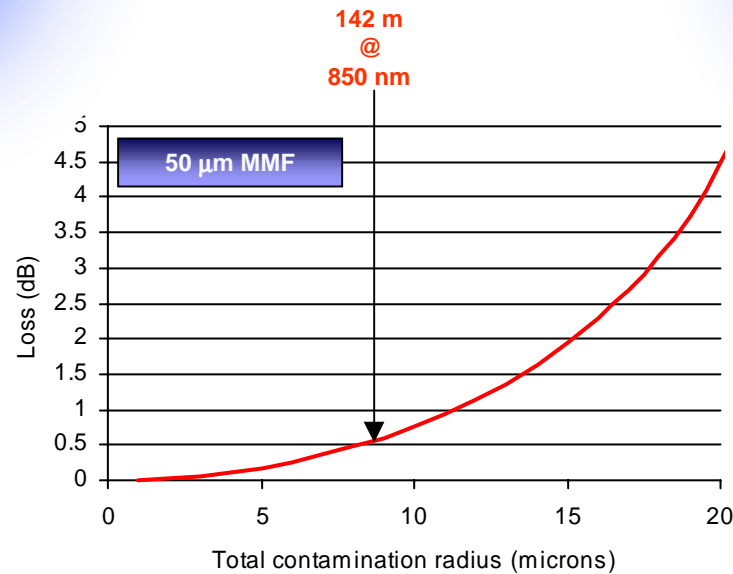
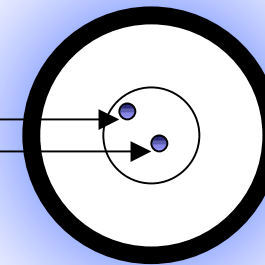



THE CHALLENGE OF THE NEW OPTICAL FIBRE TECHNOLOGIES

Mike Gilmore, The Cabling Partnership

Testing

ARENA	REFERENCE	TITLE
IEC	61280-4-1	Fibre optic communication subsystem basic test procedures - Part 4-1: Fibre optic cable plant - Multimode fibre optic cable plant
IEC	61280-4-2	Fibre optic communication subsystem basic test procedures - Part 4-2: Fibre optic cable plant - Single-mode fibre optic cable plant
EN	50346	Information Technology - Testing of installed cabling
TIA/EIA	526-14-A	OFSTP-14A Optical Power Loss Measurement of Installed Multimode Fiber Cable Plant (ANSI/TIA/EIA-526-14A-98)
TIA/EIA	526-7	OFSTP-7 Measurement of Optical Power Loss of Installed Single-Mode Fiber Cable Plant (ANSI/TIA/EIA-526-7-98)

LSPM = Light Source - Power Meter

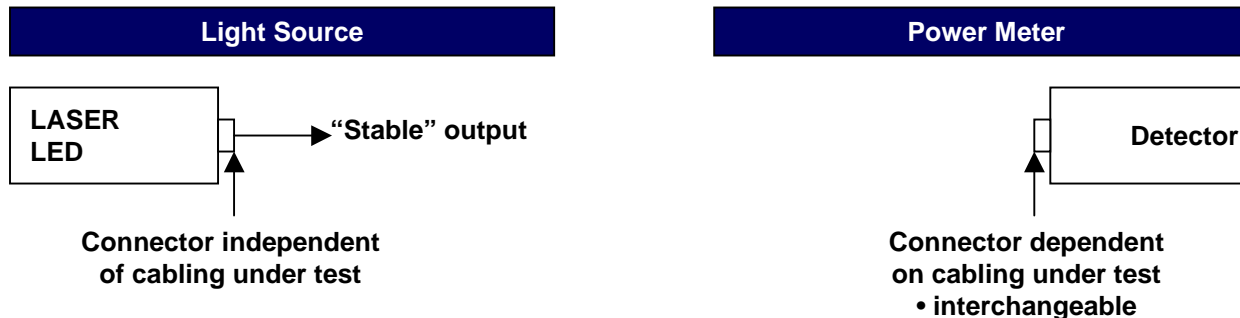



THE CHALLENGE OF THE NEW OPTICAL FIBRE TECHNOLOGIES

Mike Gilmore, The Cabling Partnership

Duplex and Duplex-able "SFF" Connectors

OptiJack



MT-RJ



Volition (3M) - SG

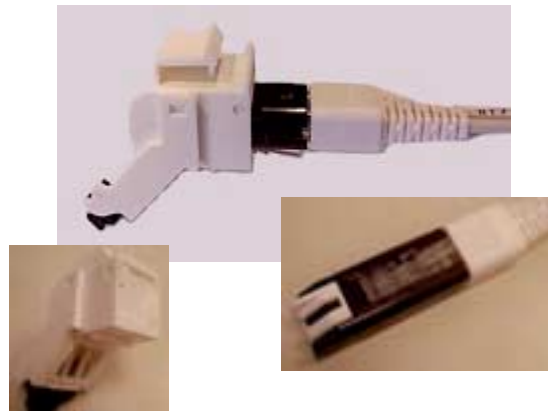

LC (Lucent)

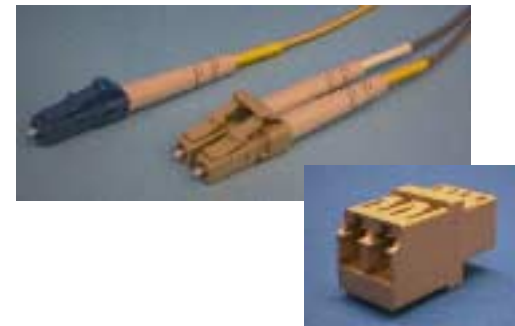



THE CHALLENGE OF THE NEW OPTICAL FIBRE TECHNOLOGIES

Mike Gilmore, The Cabling Partnership

Test Equipment

Grade 1 • simplex • single wavelength		Component- based
Grade 2 • simplex • dual wavelength		Component- based
Grade 3 • simplex • auto dual wavelength		System-based
Grade 4 • duplex • dual wavelength		System-based
Grade 5 • duplex • auto dual wavelength		System-based



Includes single location Grade 3



THE CHALLENGE OF THE NEW OPTICAL FIBRE TECHNOLOGIES

Mike Gilmore, The Cabling Partnership

FIA Technical Support Documents

 	
THE FIBREOPTIC INDUSTRY ASSOCIATION www.fibreoptic.org.uk	
TSD	DESIGN
2000-1-1	OPTICAL FIBRE CABLING: LAN APPLICATION SUPPORT GUIDE
2000-1-3	OPTICAL FIBRE CABLING: DARK FIBRE SUPPORT GUIDE
TSD	OPERATION
2000-3-3	POLARITY MAINTENANCE
TSD	INSTALLATION
2000-4-2-1	TESTING OF INSTALLED CABLING: ATTENUATION USING LSPM EQUIPMENT
2000-4-2-2	TESTING OF INSTALLED CABLING: ATTENUATION USING OTDR EQUIPMENT
TSD	SAFETY
2000-5-1	OPTICAL POWER: SAFETY LEVELS
2000-5-2	OPTICAL FIBRE: HANDLING OF PROCESSING CHEMICALS
2000-5-3	OPTICAL FIBRE: DISPOSAL OF WASTE
MODELLING TOOLS	
CABLING STRUCTURES COST MODEL	



Thank you for your time