

Testing Multimode Optical Fibre Infrastructures

Prepared and delivered for



Bisham Abbey
18th October 2001

AGENDA

Introduction

OF: Testing Philosophies
Duplex and SFF Testing

Break

Gigabit Ethernet
Launch Conditions

OTDR vs. LSPM

Conclusions

Close

Mike Gilmore

The Cabling Partnership

www.it-cabling.com

e-Ready Building

www.e-readybuilding.com

PO Box MT65, LEEDS, LS17 8YD, United Kingdom

Tel: +44 (0) 113 232 3721 Fax: +44 (0) 113 232 3724

Mike Gilmore



ISO/IEC JTC1 SC25

**Secretary: WG3: Generic Cabling
Member: Project Team: SOHO**



BSI

**Chairman TCT7/-/1: IT Cabling
Chairman TCT7/-/3: IT Cabling**



CENELEC

50173 Ed.2 (2002)

Convenor: TC215 WG1: IT Cabling

**Fibreoptic Industry Association
Standards Director
Technical Director**

FIA

The Fibreoptic Industry Association

AGENDA

Introduction

OF: Testing Philosophies
Duplex and SFF Testing

Break

Gigabit Ethernet
Launch Conditions

OTDR vs. LSPM

Conclusions

Close

FIA Documentation Update

DESIGN		
FIA-TSD-2000-1-1	OPTICAL FIBRE CABLING: LAN APPLICATION SUPPORT GUIDE	JANUARY 2001
	Revision to include mode conditioning cords and 10GBASE-xyz	JANUARY 2002
INSTALLATION		
FIA-TSD-2000-4-2-1	TESTING OF INSTALLED CABLING: ATTENUATION USING LSPM EQUIPMENT	JANUARY 2002
SAFETY		
FIA-TSD-2000-5-1	OPTICAL POWER: SAFETY LEVELS	DECEMBER 2001
FIA-TSD-2000-5-2	OPTICAL FIBRE: HANDLING OF PROCESSING CHEMICALS	
FIA-TSD-2000-5-3	OPTICAL FIBRE: DISPOSAL OF WASTE	

MODELLING TOOLS	
CABLING STRUCTURES COST MODEL	DECEMBER 2001

AGENDA

Introduction

OF: Testing Philosophies
Duplex and SFF Testing

Break

Gigabit Ethernet
Launch Conditions

OTDR vs. LSPM

Conclusions

Close

OF - Testing Philosophies

Reference Points
General Implementations
The Alternative Approaches
Testing Regimes
LSPM Test Methods
Glossary
Cabling Configurations
Test Methods
Configuration A
Configuration B
Configuration C
Impact of Incorrect Methods
LSPM Measurement Accuracy

AGENDA

Introduction

OF: Testing Philosophies
Duplex and SFF Testing

Break

Gigabit Ethernet
Launch Conditions

OTDR vs. LSPM

Conclusions

Close

Reference Points

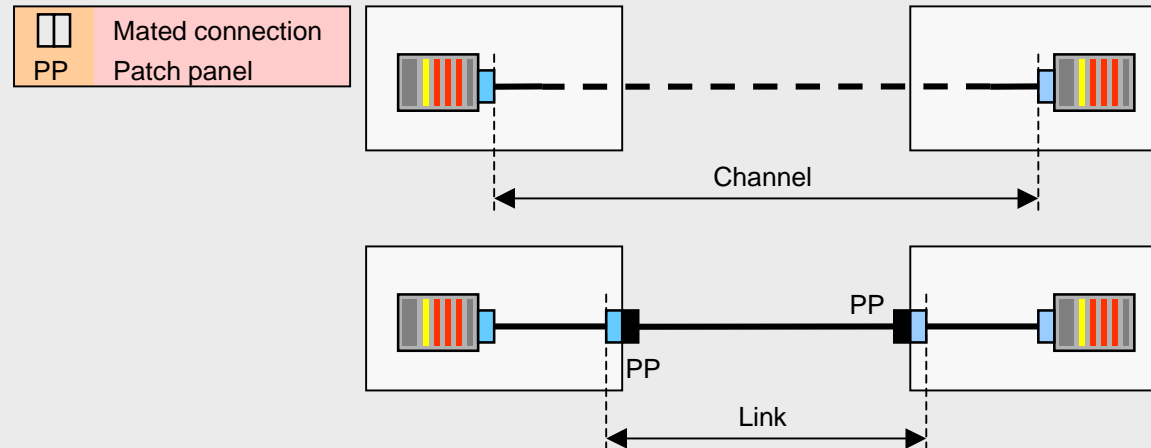

AGENDA

- Introduction
- OF: Testing Philosophies
- Duplex and SFF Testing
- Break
- Gigabit Ethernet
- Launch Conditions
- OTDR vs. LSPM
- Conclusions
- Close

General Implementations

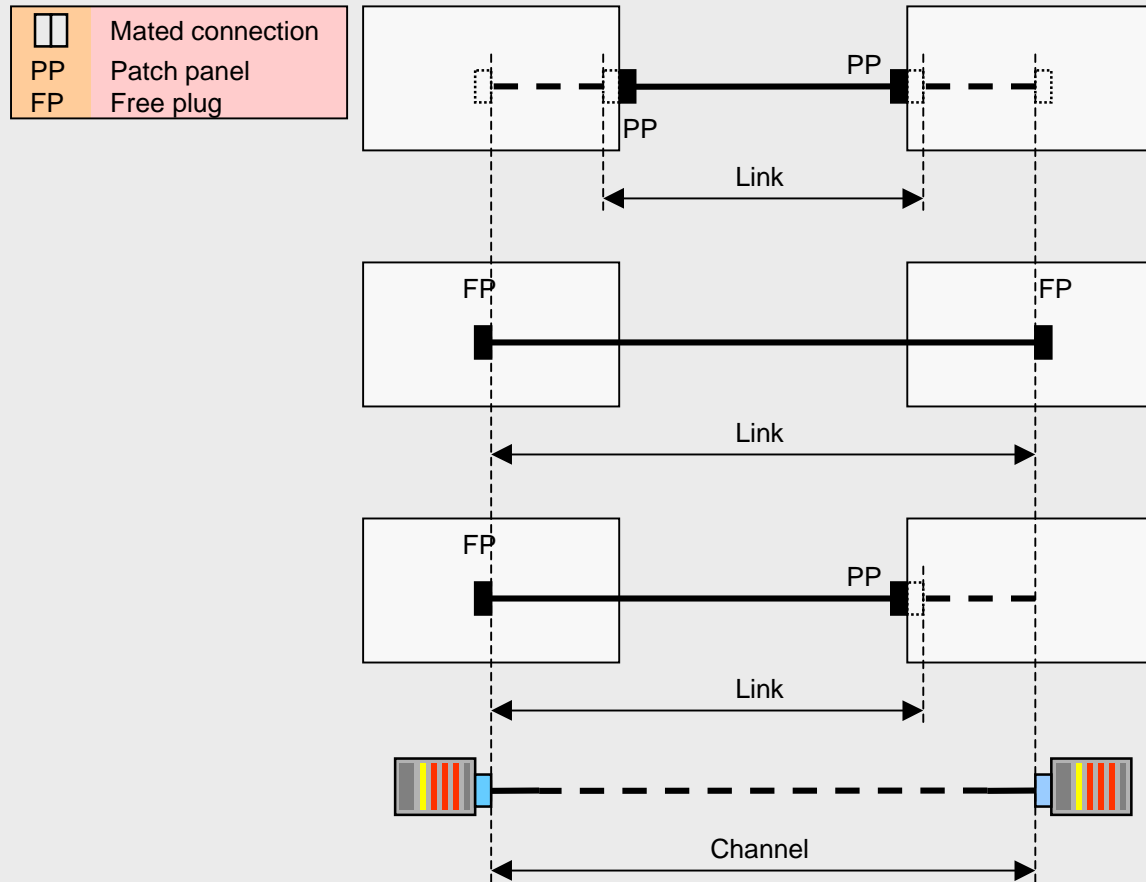

AGENDA

- Introduction
- OF: Testing Philosophies
- Duplex and SFF Testing
- Break
- Gigabit Ethernet
- Launch Conditions
- OTDR vs. LSPM
- Conclusions
- Close

The Alternative Approaches

	Optical power budget (dB)			
	MMF		SMF	
	850nm	1300nm	1310nm	
"Channel" approach	APPLICATION			
	ISO/IEC 8802-3: 10BASE-FL/FB	12,5 (6,8)		
	ISO/IEC 8802-5: TR 4/16 Mbit/s	13,0 (8,0)		
	ISO/IEC 9314-3 FDDI		11,0 (6,0)	
	ISO/IEC DIS 9314-4 FDDI		10,0	
	ISO/IEC 8802-3: 100BASE-FX		11,0 (6,0)	
	TR 100 Mbit/s		11,0 (6,0)	
	CD 14165-1: Fibre Channel-1062	4,0		6,0
	IEEE 802-3: 1000BASE-SX	2,6 (3,56)		
	IEEE 802-3: 1000BASE-LX		2,35	5,0
"Overall loss" approach	Maximum values x dB y dB z dB			
	Actual value Link < (x + y + z) dB			
"Component loss" approach	Maximum values x dB y dB z dB			
	Actual values < x dB < y dB < z dB			



AGENDA

- Introduction
- OF: Testing Philosophies
- Duplex and SFF Testing
- Break
- Gigabit Ethernet
- Launch Conditions
- OTDR vs. LSPM
- Conclusions
- Close

Testing Regimes

TEST REGIME	ITEMS UNDER TEST	TESTING APPROACH	TEST TOOL
Component Acceptance	Cables	Component	OTDR
	Cords	Overall loss	LSPM
		Component	LSPM
Legacy Cabling Acceptance	Links and channels	Overall loss	LSPM
		Component	OTDR
Partial Completion Tests	Links	Component	OTDR
Installed Cabling Acceptance	Links and channels	Overall loss	LSPM
		Component	OTDR
Fault Diagnosis	Links and channels	Component	OTDR



AGENDA

- Introduction
- OF: Testing Philosophies
- Duplex and SFF Testing
- Break
- Gigabit Ethernet
- Launch Conditions
- OTDR vs. LSPM
- Conclusions
- Close

LSPM Test Methods

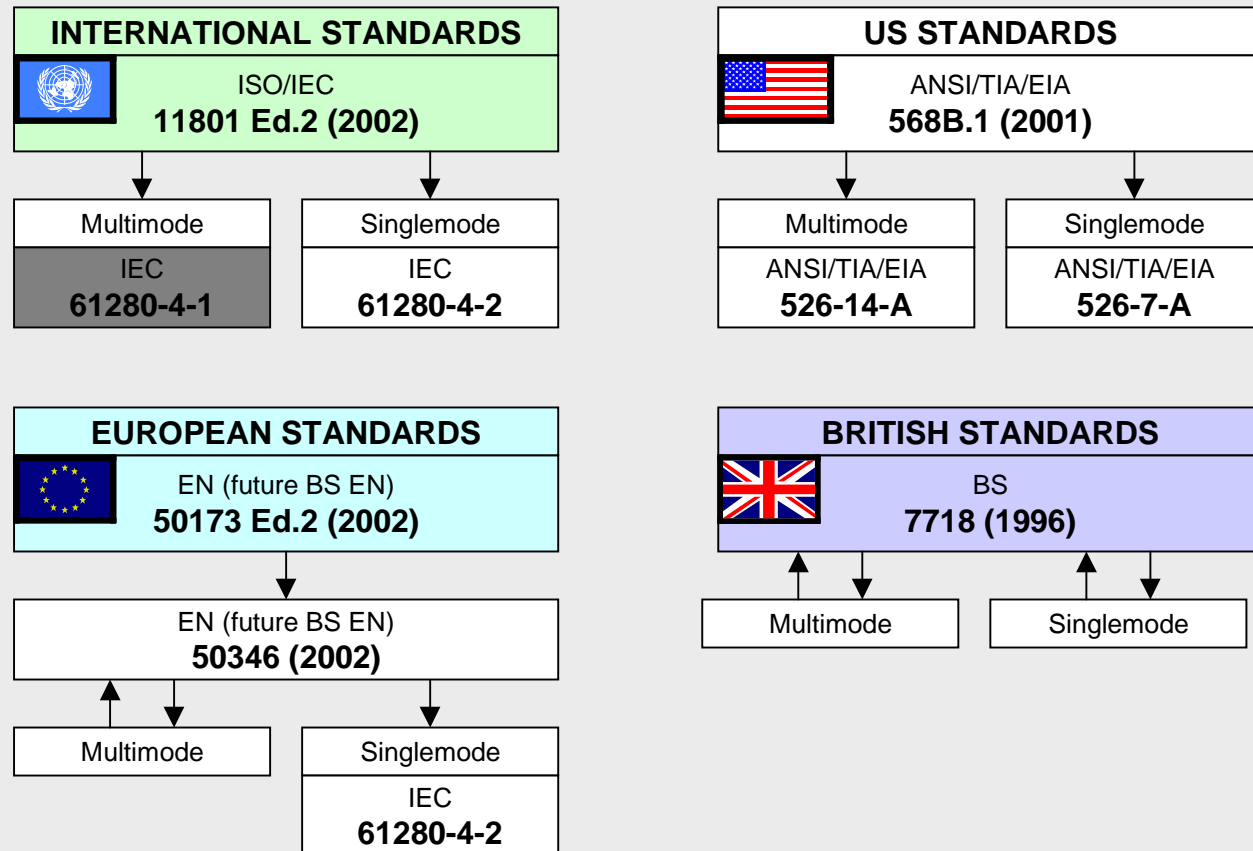

AGENDA

Introduction

OF: Testing Philosophies
Duplex and SFF Testing

Break

Gigabit Ethernet
Launch Conditions

OTDR vs. LSPM

Conclusions

Close

LSPM Test Method Glossary

ARENA	REFERENCE	TITLE
IEC	61280-4-1	Fibre optic communication subsystem basic test procedures - Part 4-1: Fibre optic cable plant - Multimode fibre optic cable plant attenuation
IEC	61280-4-2	Fibre optic communication subsystem basic test procedures - Part 4-2: Fibre optic cable plant - Single-mode fibre optic cable plant attenuation
EN	50346	Information Technology - Testing of installed cabling
TIA/EIA	526-14-A	OFSTP-14A Optical Power Loss Measurement of Installed Multimode Fiber Cable Plant (ANSI/TIA/EIA-526-14A-98)
TIA/EIA	526-7	OFSTP-7 Measurement of Optical Power Loss of Installed Single-Mode Fiber Cable Plant (ANSI/TIA/EIA-526-7-98)

AGENDA

- Introduction
- OF: Testing Philosophies
- Duplex and SFF Testing
- Break
- Gigabit Ethernet
- Launch Conditions
- OTDR vs. LSPM
- Conclusions
- Close

Cabling Configurations

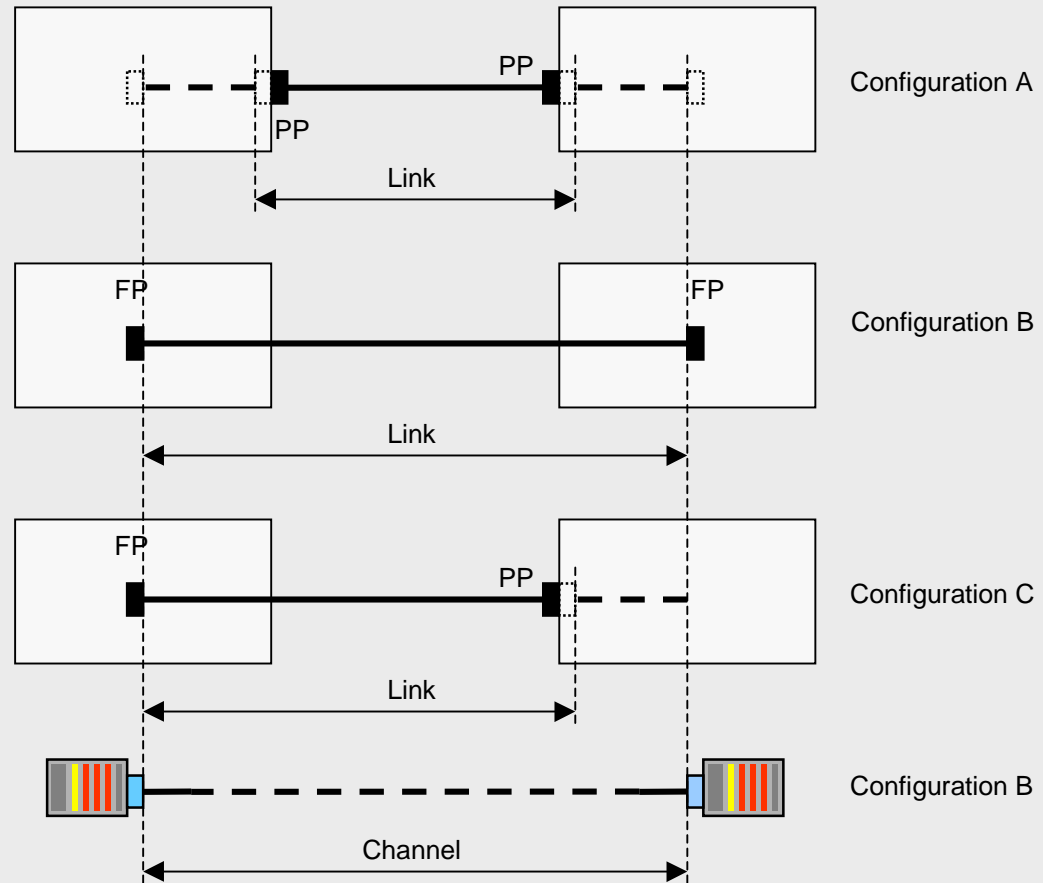



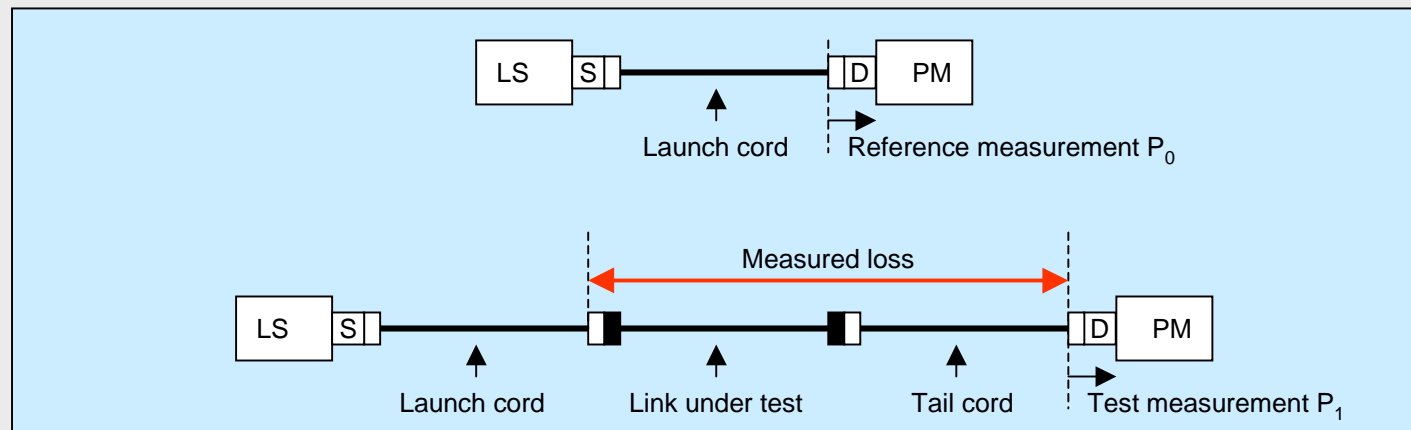
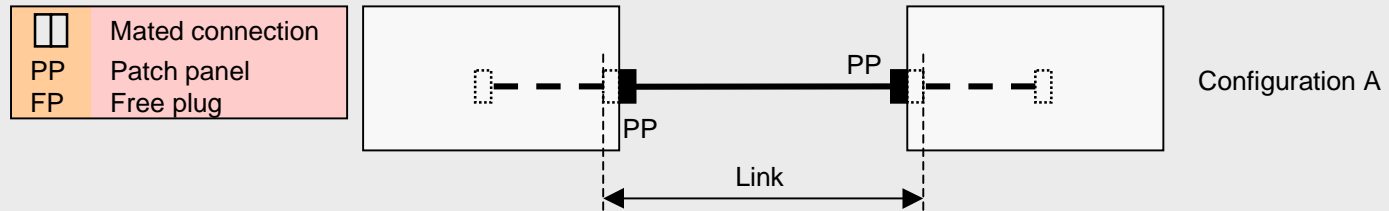

AGENDA

- Introduction
- OF: Testing Philosophies
- Duplex and SFF Testing
- Break
- Gigabit Ethernet
- Launch Conditions
- OTDR vs. LSPM
- Conclusions
- Close

Configuration A Test Method



Loss = $P_1 - P_0$ (dB)

	MMF: not applicable		MMF: EN 50346 Method 1		MMF:-526-14-A Method B
	SMF: IEC 61280-4-2 Method 1.A		SMF: IEC 61280-4-2 Method 1.A		SMF:-526-7 Method A.1
			BS 7718: Configuration A		





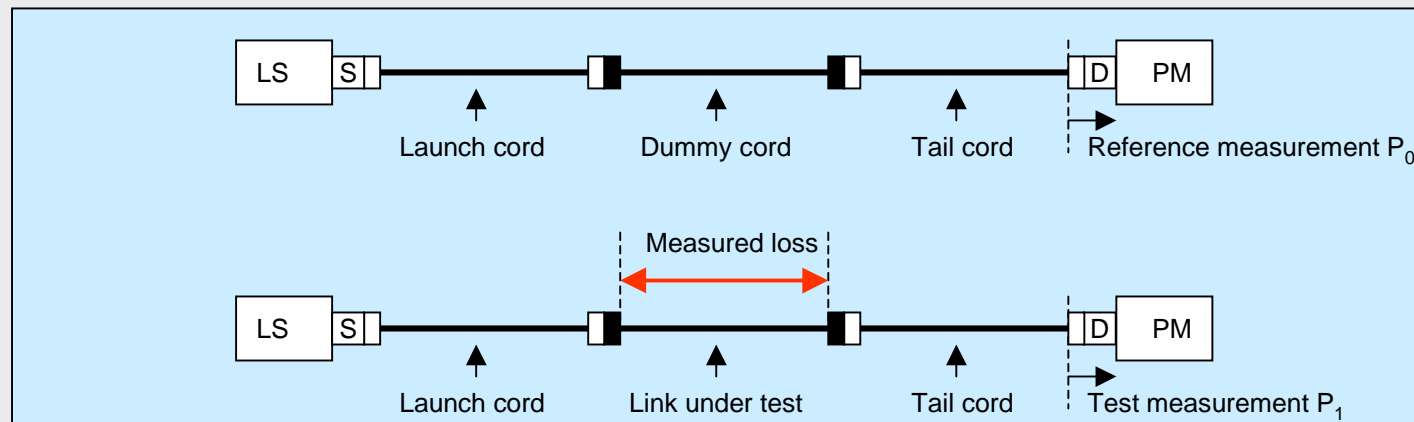
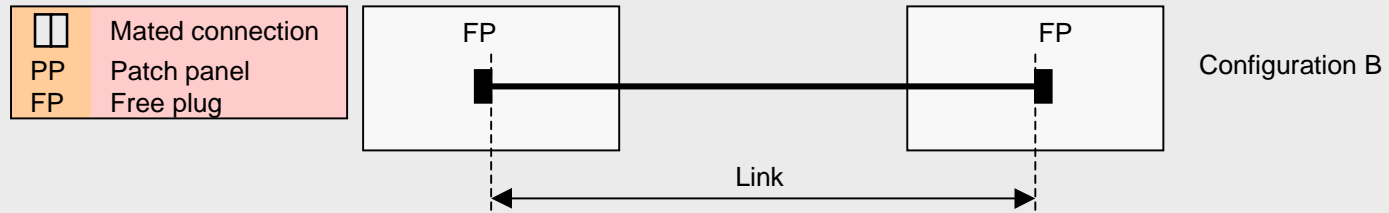

AGENDA

- Introduction
- OF: Testing Philosophies
- Duplex and SFF Testing
- Break
- Gigabit Ethernet
- Launch Conditions
- OTDR vs. LSPM
- Conclusions
- Close

Configuration B Test Method



Loss = P₁ - P₀ (dB)

	MMF: not applicable		MMF: EN 50346 Method 2		MMF:-526-14-A Method C
	SMF: IEC 61280-4-2 Method 1.C		SMF: IEC 61280-4-2 Method 1.C		SMF:-526-7
			BS 7718: Configuration B		





AGENDA

- Introduction
- OF: Testing Philosophies
- Duplex and SFF Testing
- Break
- Gigabit Ethernet
- Launch Conditions
- OTDR vs. LSPM
- Conclusions
- Close

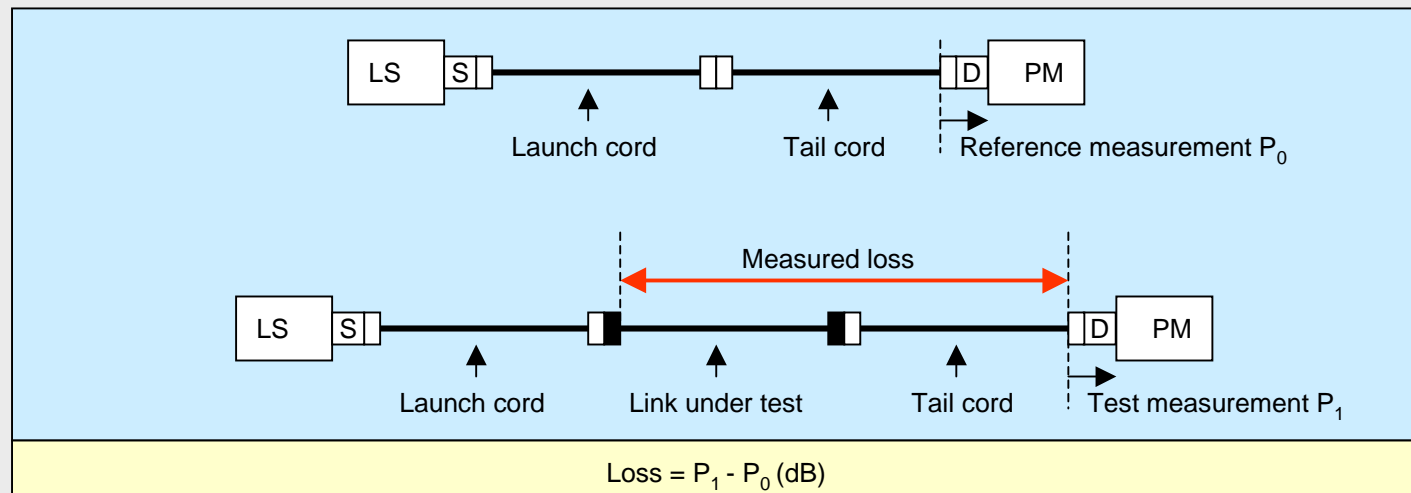
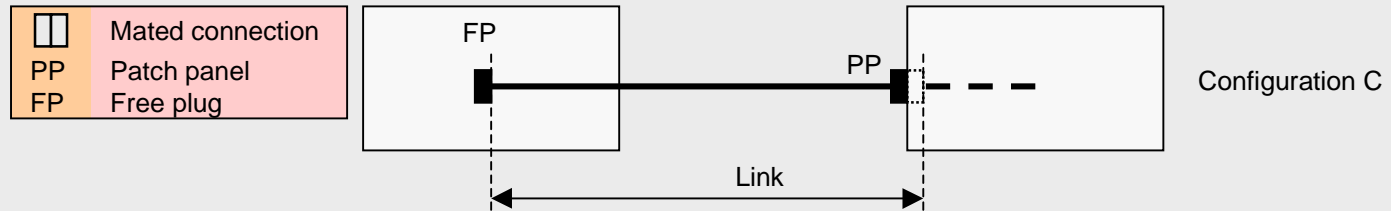
Configuration C Test Method



	MMF: not applicable		MMF:-526-14-A Method A
	SMF: IEC 61280-4-2 Method 1.B		SMF:-526-7
		BS 7718: Configuration C	



AGENDA

- Introduction
- OF: Testing Philosophies
Duplex and SFF Testing
- Break
- Gigabit Ethernet
Launch Conditions
- OTDR vs. LSPM
- Conclusions
- Close

Impact of Incorrect Methods

INSTALLED LINK	METHOD APPLIED	RESULT
CONFIGURATION A	CONFIGURATION A	CORRECT
	CONFIGURATION B	LOW BY 2 CONNECTIONS
	CONFIGURATION C	LOW BY 1 CONNECTION
CONFIGURATION B	CONFIGURATION A	HIGH BY 2 CONNECTIONS
	CONFIGURATION B	CORRECT
	CONFIGURATION C	HIGH BY 1 CONNECTION
CONFIGURATION C	CONFIGURATION A	HIGH BY 1 CONNECTION
	CONFIGURATION B	LOW BY 1 CONNECTION
	CONFIGURATION C	CORRECT

INSTALLED CHANNEL	METHOD APPLIED	RESULT
CONFIGURATION B	CONFIGURATION A	HIGH BY 2 CONNECTIONS
	CONFIGURATION B	CORRECT
	CONFIGURATION C	HIGH BY 1 CONNECTION

All measurements are subject to the fundamental accuracy of the technique



AGENDA

- Introduction
- OF: Testing Philosophies
- Duplex and SFF Testing
- Break
- Gigabit Ethernet
- Launch Conditions
- OTDR vs. LSPM
- Conclusions
- Close

LSPM Measurement Accuracy

CORE		$Loss = -10 \log_{10} \left[\left(\frac{d_2}{d_1} \right)^2 \right]$ <p>dB from large core to small core (0 dB from small to large)</p>
CORE		$Loss = -10 \log_{10} \left[\left(\frac{NA_2}{NA_1} \right)^2 \right]$ <p>dB from large NA to small NA (0 dB from small to large)</p>
CORE		$Loss = -10 \log_{10} \left[\frac{1}{90} \tan^{-1} \left(\frac{de}{x} \right) - \frac{2xe}{\pi d} \right]$ <p>dB in both directions</p> $e = \left[1 - \left(\frac{x}{d} \right)^2 \right]^{0.5}$

AGENDA

- Introduction
- OF: Testing Philosophies
- Duplex and SFF Testing
- Break
- Gigabit Ethernet
- Launch Conditions
- OTDR vs. LSPM
- Conclusions
- Close

LSPM Measurement Accuracy

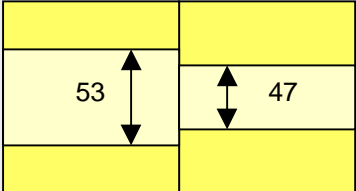
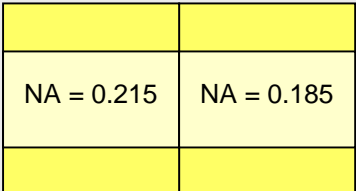
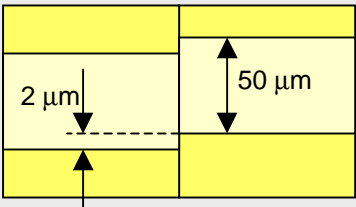
CORE		$Loss = -10 \log_{10} \left[\left(\frac{47}{53} \right)^2 \right]$	= -1.04 dB	Applied statistics and real manufacturing tolerances suggest combined value < -0.35 dB per joint
CORE		$Loss = -10 \log_{10} \left[\left(\frac{0.185}{0.215} \right)^2 \right]$	= -1.30 dB	
CORE		Loss	= -0.47 dB	

Measurement accuracy of LSPM systems = 0.7 dB plus other mismatches



AGENDA

Introduction

OF: Testing Philosophies
Duplex and SFF Testing

Break

Gigabit Ethernet
Launch Conditions

OTDR vs. LSPM

Conclusions

Close

Duplex and SFF Testing

- Duplex Cabling
 - General Test Methods
 - Configuration A
 - Configuration B
 - Duplex Test Equipment
 - Specific Test Methods
 - Uni-Directional Test Equipment
 - Configuration A
 - Channel
 - Bi-Directional Test Equipment
 - Configuration A
 - SFF Connections
 - Specific Test Methods
 - Configuration A
 - Channel
 - The Importance of Cords

AGENDA

- Introduction
- OF: Testing Philosophies
- Duplex and SFF Testing
- Break
- Gigabit Ethernet
- Launch Conditions
- OTDR vs. LSPM
- Conclusions
- Close

Duplex Cabling

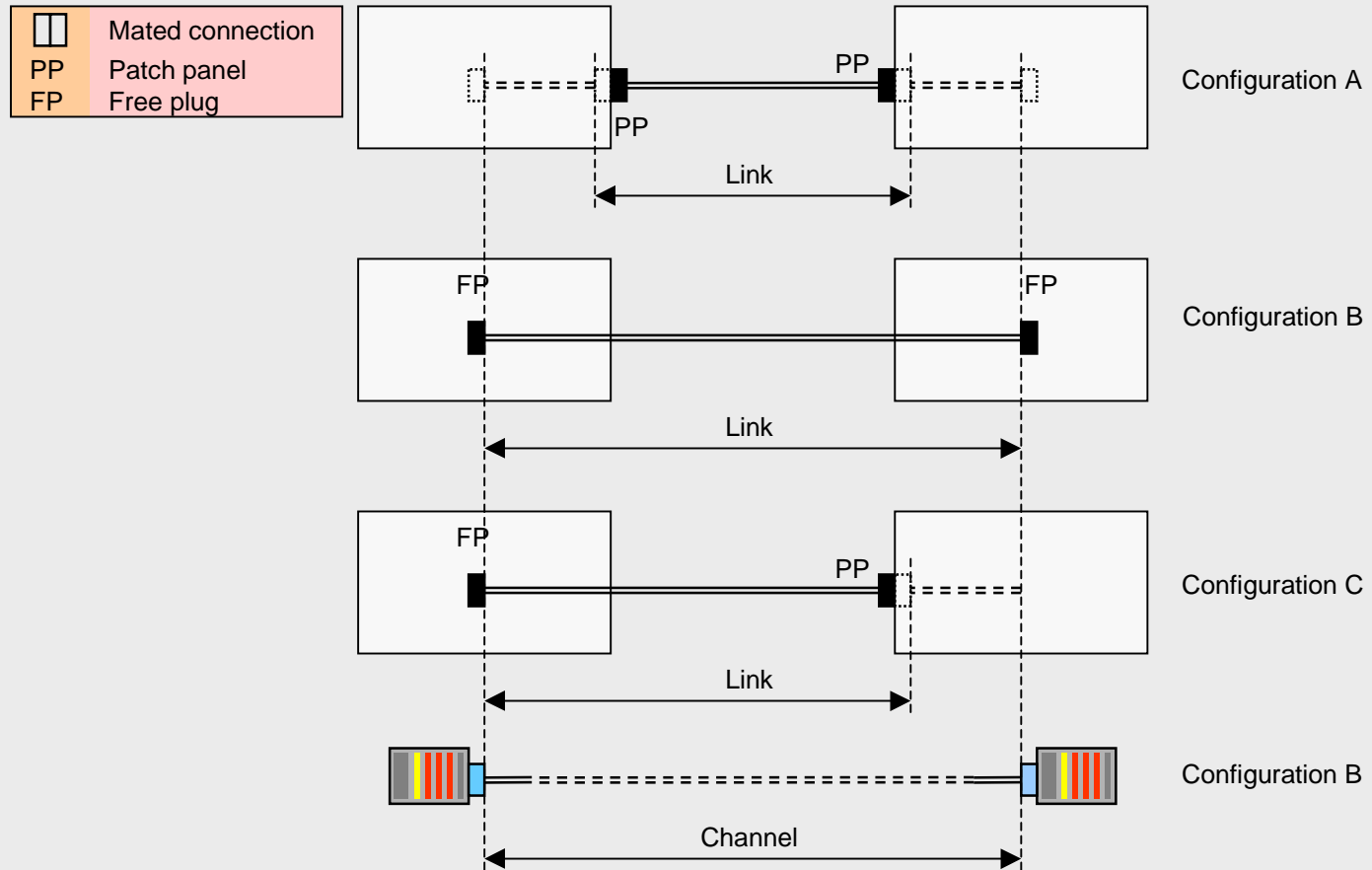



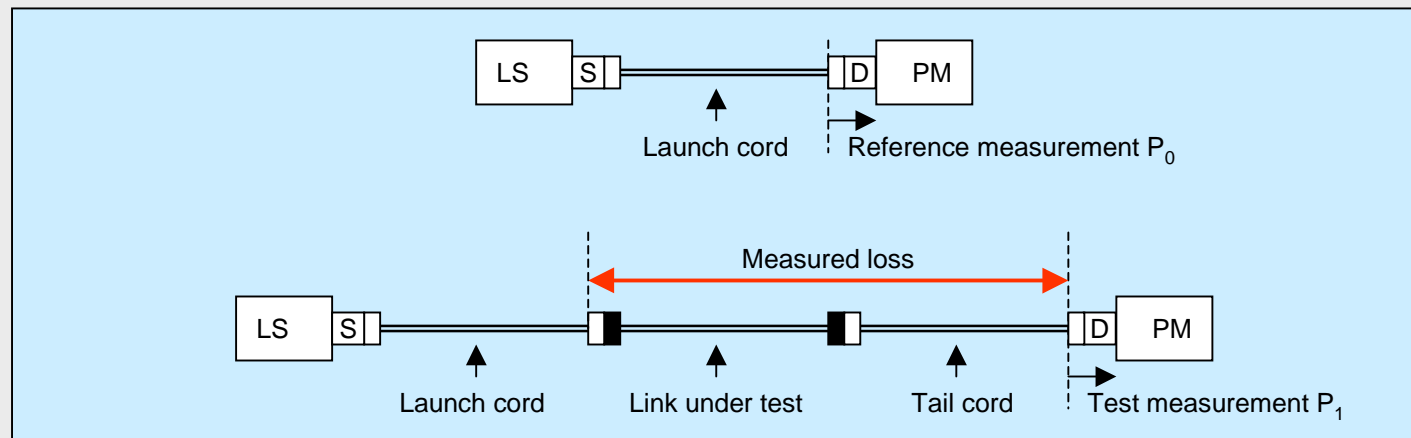
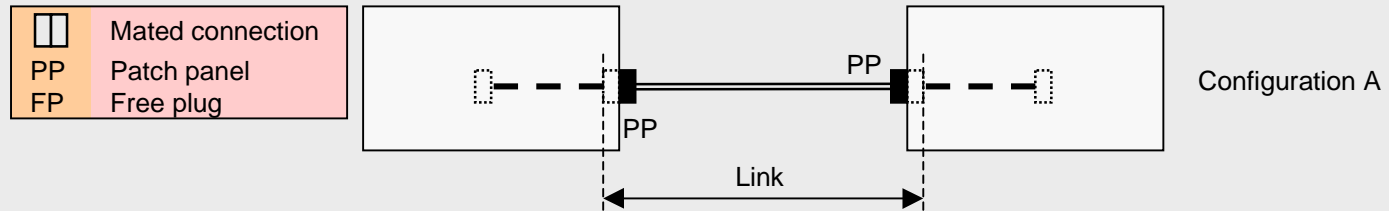

AGENDA

- Introduction
- OF: Testing Philosophies
- Duplex and SFF Testing
- Break
- Gigabit Ethernet
- Launch Conditions
- OTDR vs. LSPM
- Conclusions
- Close

Configuration A Test Method



Loss = $P_1 - P_0$ (dB)

	MMF: not applicable		MMF: EN 50346 Method 1		MMF:-526-14-A Method B
	SMF: IEC 61280-4-2 Method 1.A		SMF: IEC 61280-4-2 Method 1.A		SMF:-526-7 Method A.1
			BS 7718: Configuration A		





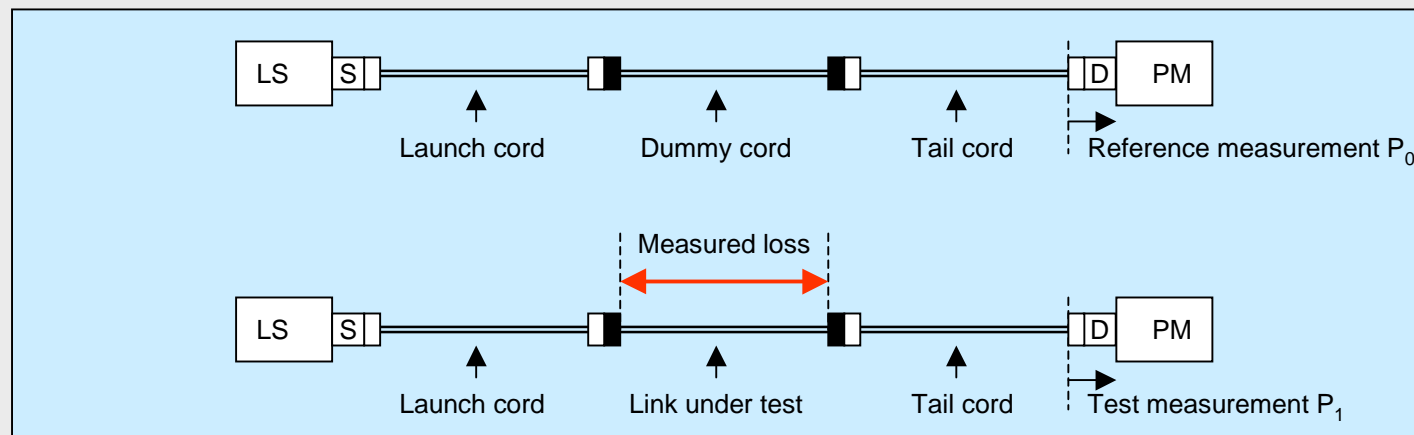
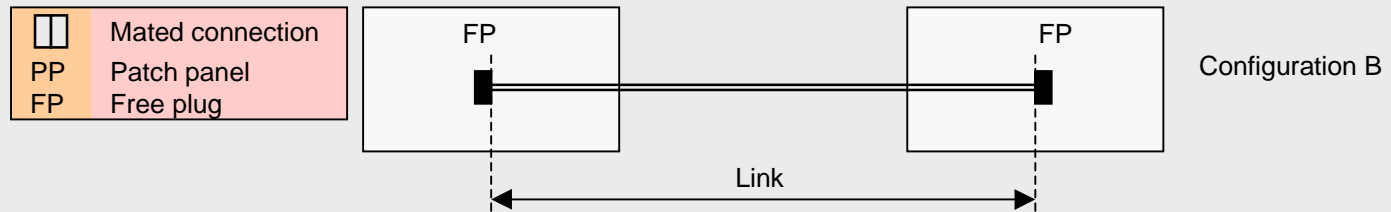

AGENDA

- Introduction
- OF: Testing Philosophies
- Duplex and SFF Testing
- Break
- Gigabit Ethernet
- Launch Conditions
- OTDR vs. LSPM
- Conclusions
- Close

Configuration B Test Method



Loss = $P_1 - P_0$ (dB)

	MMF: not applicable		MMF: EN 50346 Method 2		MMF:-526-14-A Method C
	SMF: IEC 61280-4-2 Method 1.C		SMF: IEC 61280-4-2 Method 1.C		SMF:-526-7
			BS 7718: Configuration B		



AGENDA

- Introduction
- OF: Testing Philosophies
- Duplex and SFF Testing
- Break
- Gigabit Ethernet
- Launch Conditions
- OTDR vs. LSPM
- Conclusions
- Close

Duplex Test Equipment

EQUIPMENT TYPE	EQUIPMENT TYPE	GENERAL RULES
Uni-directional duplex		Link testing rules Configuration A: OK Configuration B: OK Configuration C: OK Channel tests: OK
Bi-directional duplex		Link testing rules Configuration A: test as channel Configuration B: OK Configuration C: test as channel Channel tests: OK



AGENDA

- Introduction
- OF: Testing Philosophies
- Duplex and SFF Testing
- Break
- Gigabit Ethernet
- Launch Conditions
- OTDR vs. LSPM
- Conclusions
- Close

Link Configuration A Test - I

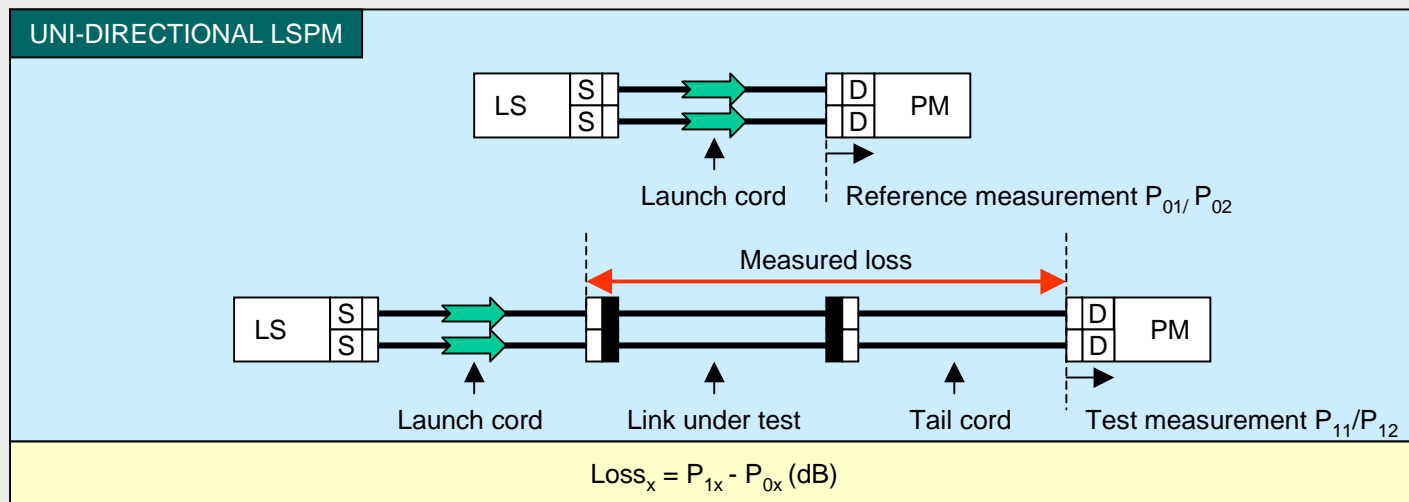
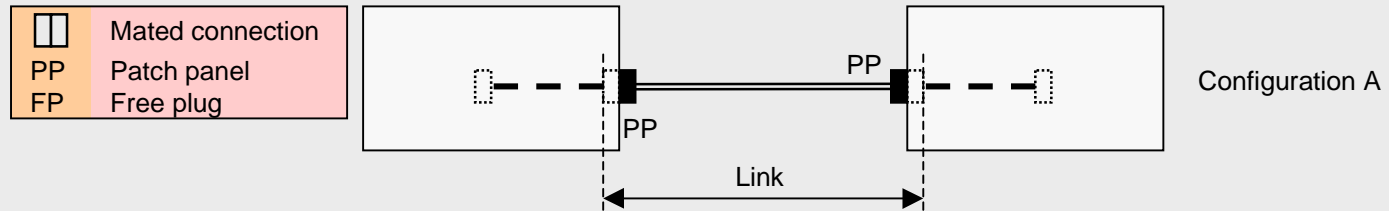

AGENDA

- Introduction
- OF: Testing Philosophies
- Duplex and SFF Testing
- Break
- Gigabit Ethernet
- Launch Conditions
- OTDR vs. LSPM
- Conclusions
- Close

Link Configuration A Test - II

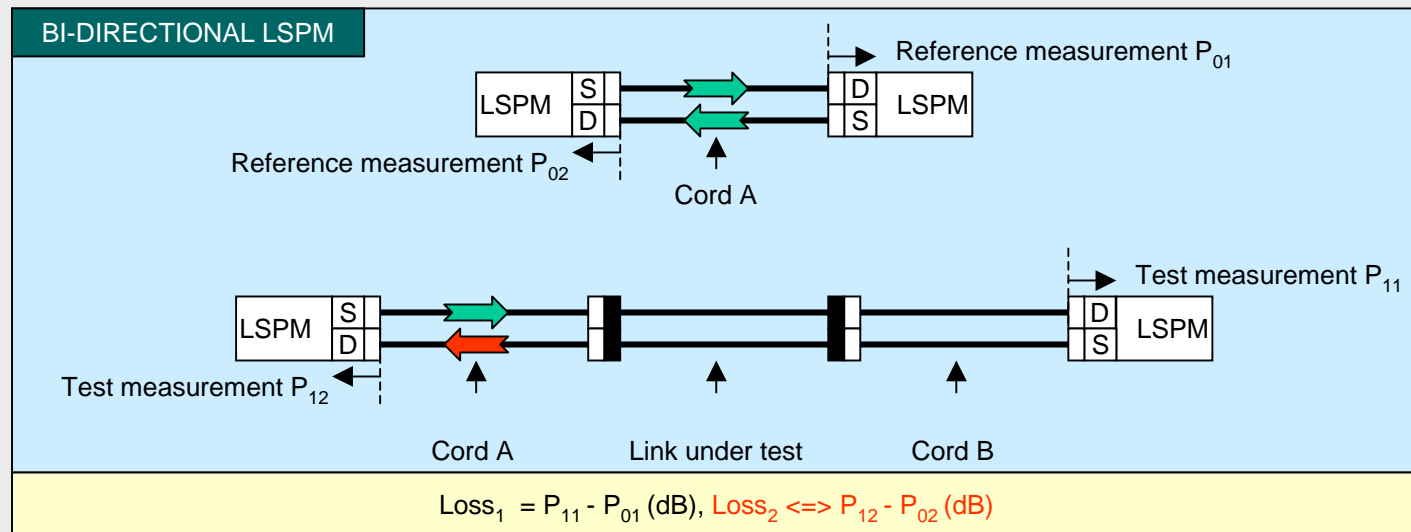
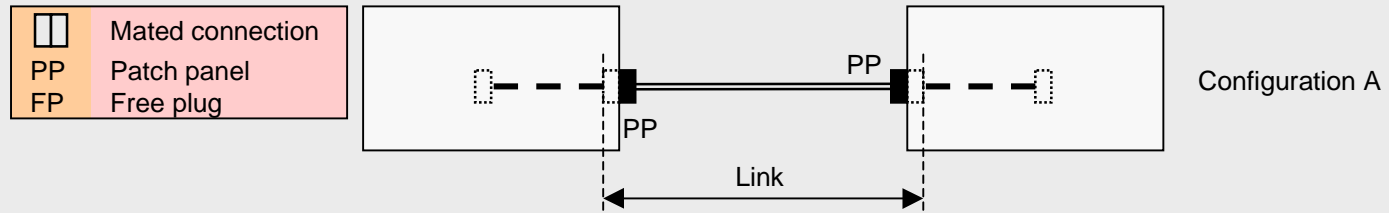

Test measurement P_{12} will be influenced by removal of Cord A from RH LSPM
 Unless LSPM guarantees that coupled power into Cord B is the same as Cord A, measurement error may occur

AGENDA

- Introduction
- OF: Testing Philosophies
- Duplex and SFF Testing
- Break
- Gigabit Ethernet
- Launch Conditions
- OTDR vs. LSPM
- Conclusions
- Close

Channel Test

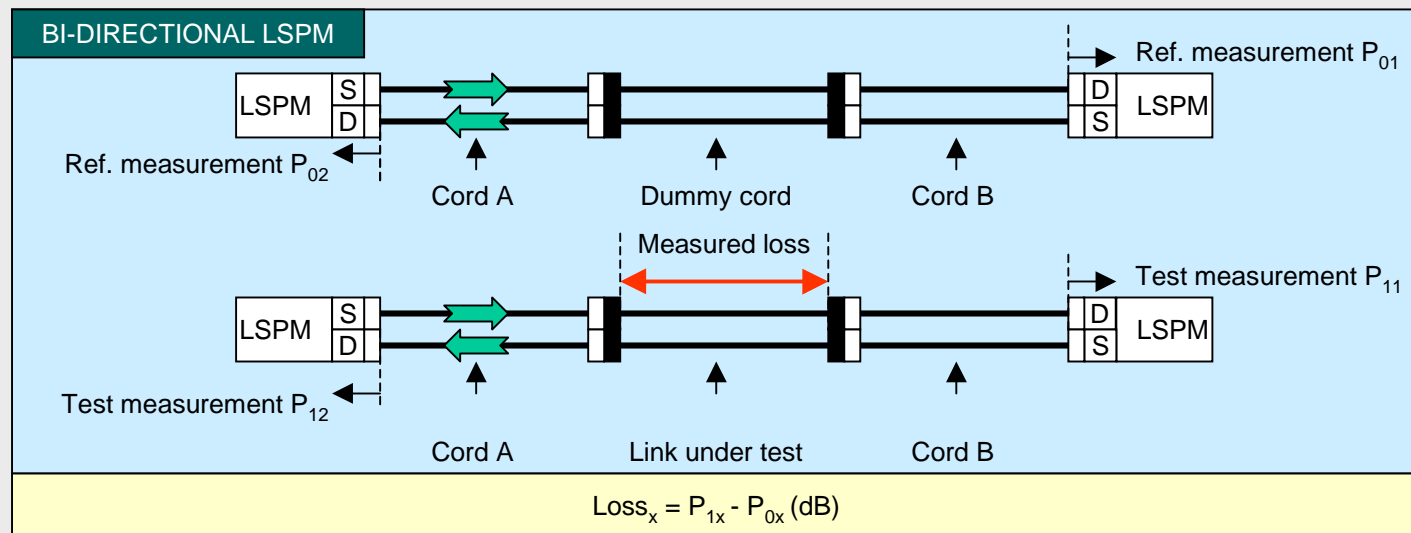
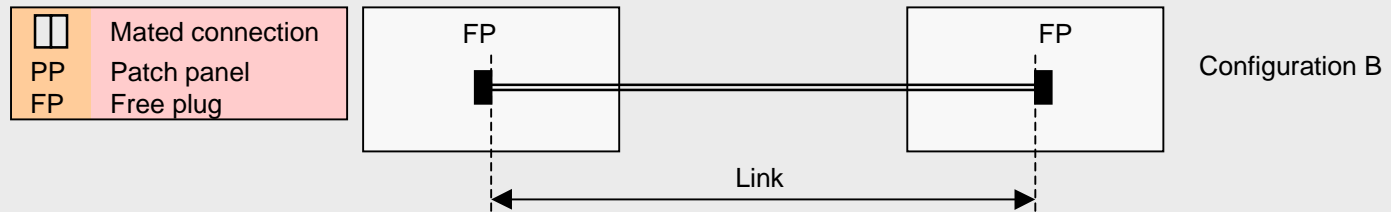

AGENDA

- Introduction
- OF: Testing Philosophies
- Duplex and SFF Testing
- Break
- Gigabit Ethernet
- Launch Conditions
- OTDR vs. LSPM
- Conclusions
- Close

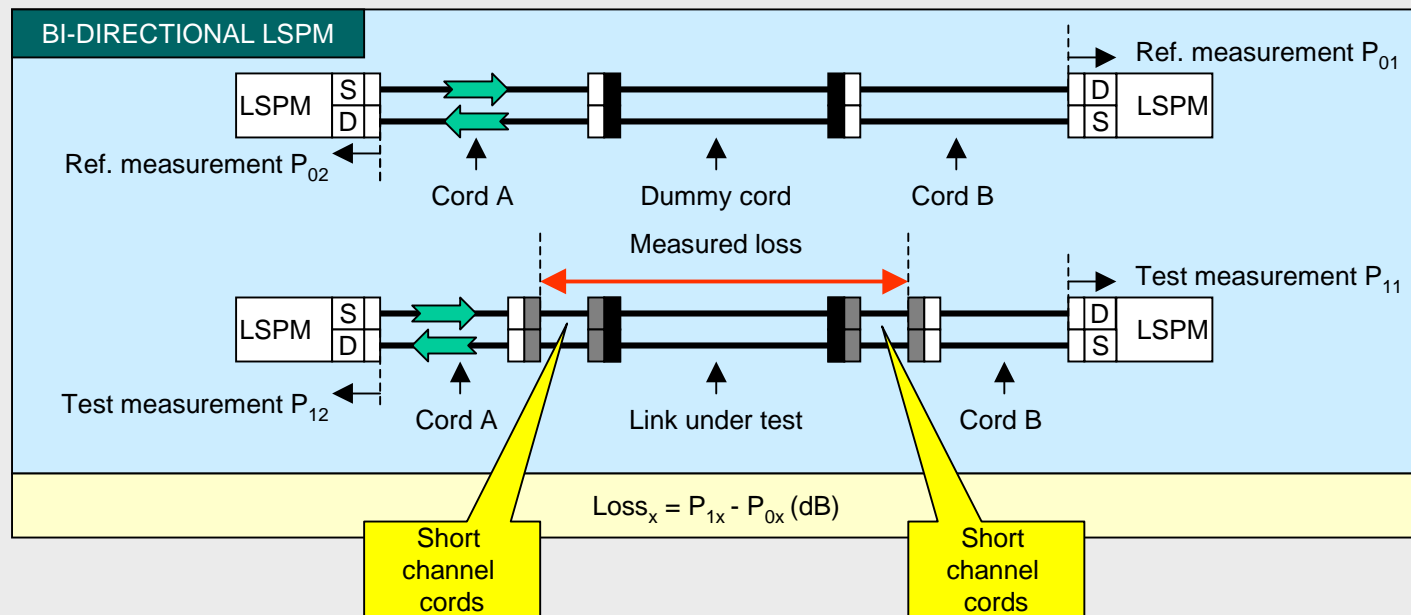
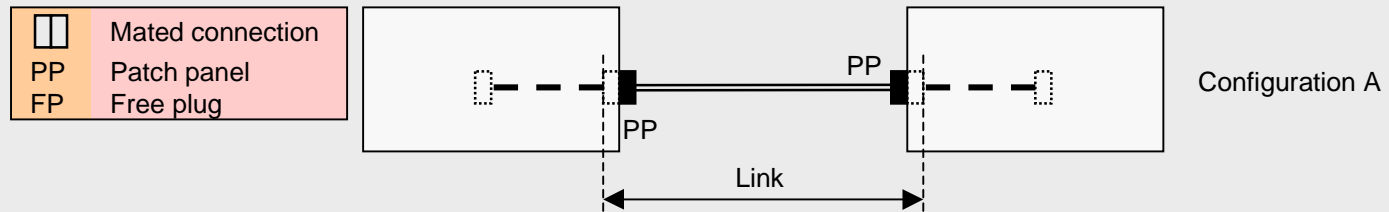

Link Configuration A Test



AGENDA

- Introduction
- OF: Testing Philosophies
- Duplex and SFF Testing
- Break
- Gigabit Ethernet
- Launch Conditions
- OTDR vs. LSPM
- Conclusions
- Close

SFF Connections

IT CABLING STANDARDS			
	ISO/IEC 11801 Ed. 2 (2002)		EN 50173 Ed. 2 (2002)
	2nd CDV: Document N696		6MP Document BS EN 50173 Ed. 2 (2002)



Mating dimensions and gauging of TO connection					
SC Duplex		IEC 60874-19-1			
	Wavelength	Multimode OF		Singlemode OF	
		Connection	Splice	Connection	Splice
Return loss (dB min)	All	20dB	NA	35dB	NA
Attenuation (dB max)	All	95%<0,5 100%<0,75	100%<0,3	95%<0,5 100%<0,75	100%<0,3



AGENDA

- Introduction
- OF: Testing Philosophies
- Duplex and SFF Testing
- Break
- Gigabit Ethernet
- Launch Conditions
- OTDR vs. LSPM
- Conclusions
- Close

SFF Connections

IT CABLING STANDARDS			
	ISO/IEC 11801 Ed. 2 (2002)		EN 50173 Ed. 2 (2002)
	2nd CDV: Document N696		6MP Document BS EN 50173 Ed. 2 (2002)

Mating dimensions and gauging of TO connection					
SC Duplex		IEC 60874-19-1			
	Wavelength	Multimode OF		Singlemode OF	
		Connection	Splice	Connection	Splice
Return loss (dB min)	All	20dB	NA	35dB	NA
Attenuation (dB max)	All	95%<0,5 100%<0,75	100%<0,3	95%<0,5 100%<0,75	100%<0,3

Requirements for areas other than the telecommunications outlet

The optical fibre connectors used shall meet the requirements ..., with exception of the physical dimensions.... In areas other than the work area, the choice of connecting hardware is open to all types of optical fibre connectors **standardized by IEC.**

When high density is an important consideration **Small Form Factor** connector designs that accommodate at least two fibres within the footprint of an EN 60603-7 connector are recommended.

However, where detail specifications produced by IEC or CENELEC in accordance with requirements of do not exist then **assurance should be sought from suppliers that the combinations of components** within connecting hardware are able to meet the optical and mechanical requirements of this clause.



AGENDA

Introduction

OF: Testing Philosophies
Duplex and SFF Testing

Break

Gigabit Ethernet
Launch Conditions

OTDR vs. LSPM

Conclusions

Close

Symmetric and Asymmetric

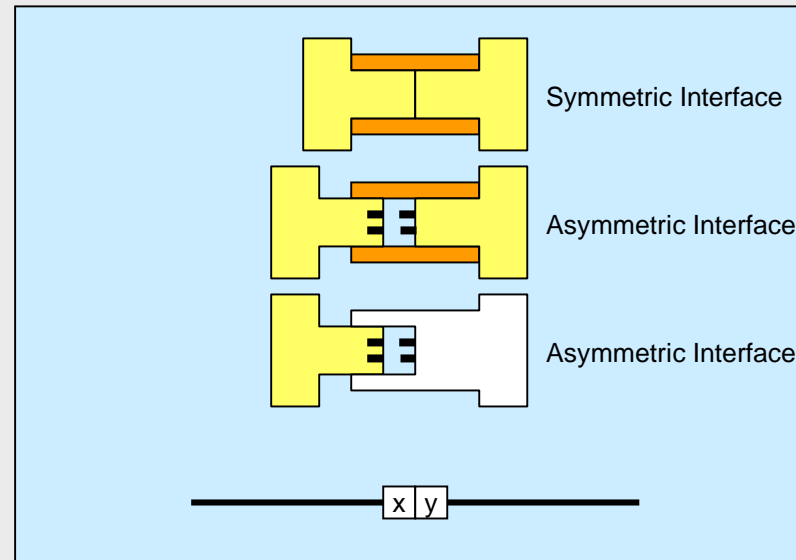

AGENDA

- Introduction
- OF: Testing Philosophies
- Duplex and SFF Testing
- Break
- Gigabit Ethernet
- Launch Conditions
- OTDR vs. LSPM
- Conclusions
- Close

Configuration A Link Testing

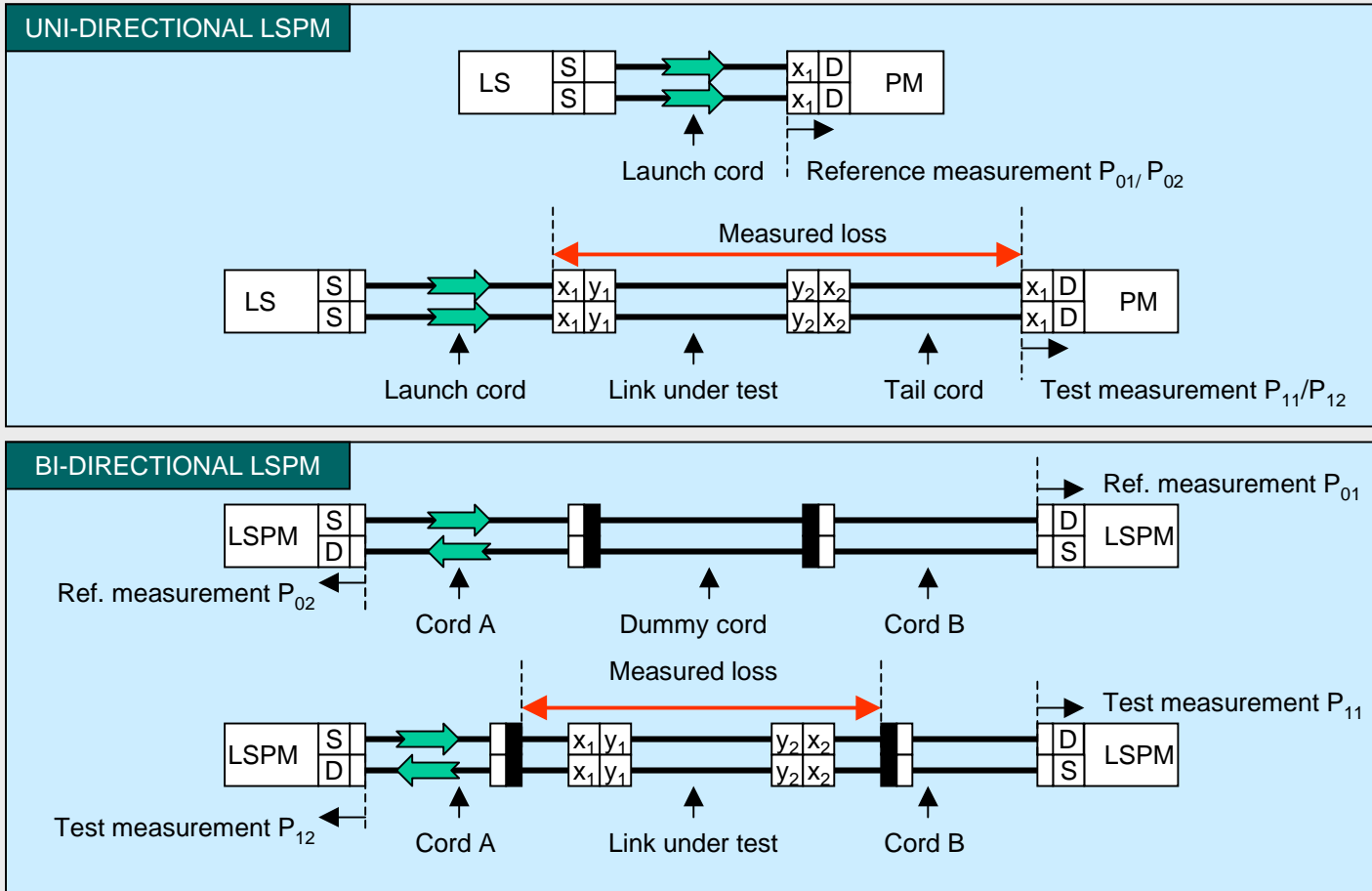

AGENDA

- Introduction
- OF: Testing Philosophies
- Duplex and SFF Testing
- Break
- Gigabit Ethernet Launch Conditions
- OTDR vs. LSPM
- Conclusions
- Close

Channel Testing

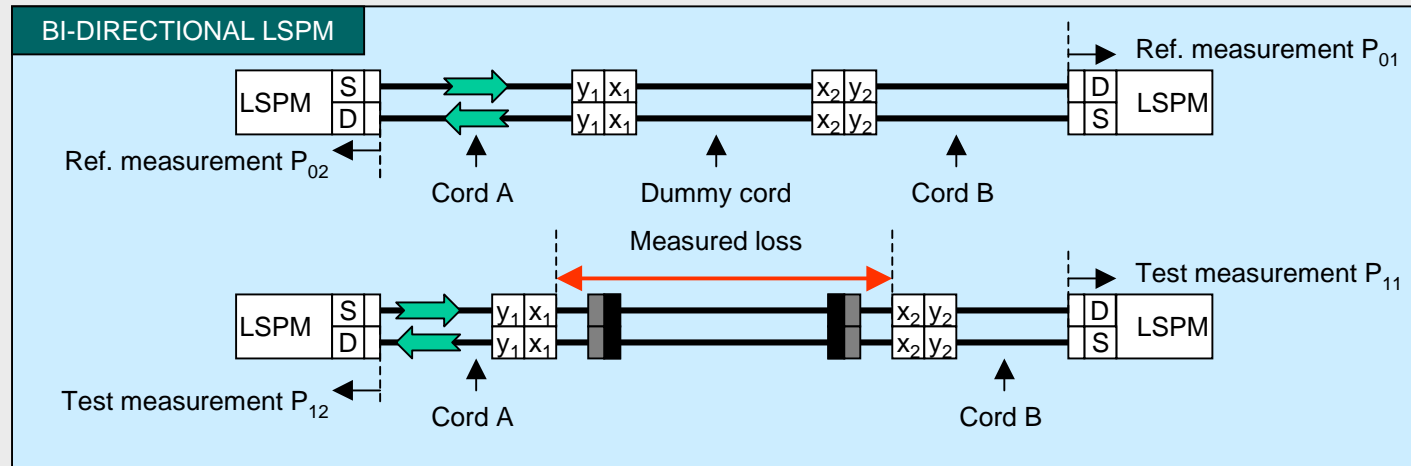

AGENDA

Introduction

OF: Testing Philosophies
Duplex and SFF Testing

Break

Gigabit Ethernet
Launch Conditions

OTDR vs. LSPM

Conclusions

Close

The Importance of Cords

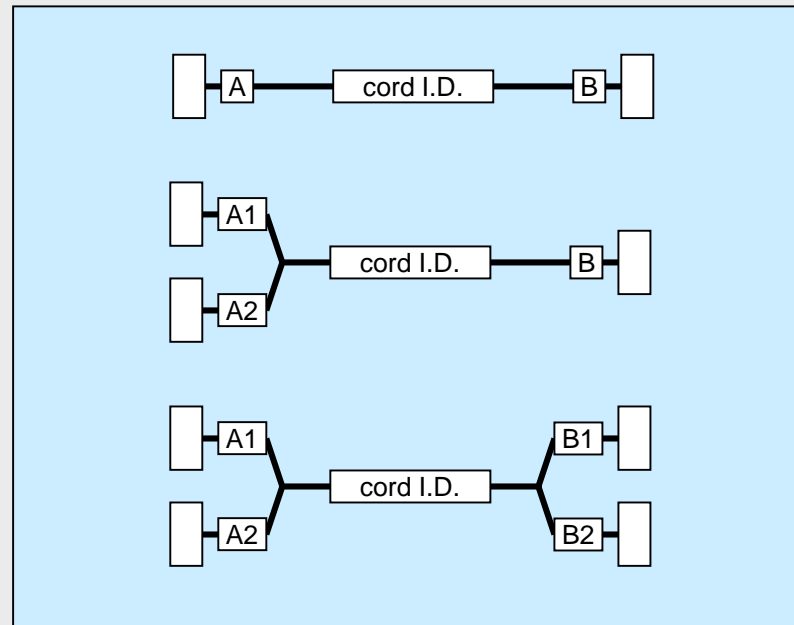

AGENDA

Introduction

OF: Testing Philosophies
Duplex and SFF Testing

Break

Gigabit Ethernet
Launch Conditions

OTDR vs. LSPM

Conclusions

Close

Break

FIA

The Fibreoptic Industry Association



AGENDA

Introduction

OF: Testing Philosophies
Duplex and SFF Testing

Break

Gigabit Ethernet
Launch Conditions

OTDR vs. LSPM

Conclusions

Close

Optical Fibre Categories
Optical Power Budgets
Measurement Error
Pass/Fail Indicators

Gigabit Ethernet



FIA

The Fibreoptic Industry Association

AGENDA

- Introduction
- OF: Testing Philosophies
- Duplex and SFF Testing
- Break
- Gigabit Ethernet
- Launch Conditions
- OTDR vs. LSPM
- Conclusions
- Close

Optical Fibre Categories

IT CABLING STANDARDS			
	ISO/IEC 11801 Ed. 2 (2002)		EN 50173 Ed. 2 (2002)
	2nd CDV: Document N696		6MP Document BS EN 50173 Ed. 2 (2002)



	Wavelength	Multimode OF			Wavelength	Singlemode OF
		50/125 or 62.5/125				
		OM1	OM2	OM3		OS1
Attenuation coefficient (dBkm ⁻¹ max)	850nm	3,5			1310nm	1,0
	1300nm	1,5			1550nm	1,0
Modal bandwidth OFL (MHz.km min)	850nm	200	500	500		
	1300nm	500	500	500		
Modal bandwidth LL (MHz.km min)	850nm	ffs	ffs	2000		
	1300nm	ffs	ffs	ffs		
Propagation delay (ns.m ⁻¹ max)	850nm	5			1310nm	5
	1300nm				1550nm	



AGENDA

- Introduction
- OF: Testing Philosophies
- Duplex and SFF Testing
- Break
- Gigabit Ethernet
- Launch Conditions
- OTDR vs. LSPM
- Conclusions
- Close

Optical Fibre Categories

IT CABLING STANDARDS			
	ISO/IEC 11801 Ed. 2 (2002)		EN 50173 Ed. 2 (2002)
	FCD: Document N739		Next draft (3MV)
			BS EN 50173 Ed. 2 (2002)

	Wavelength	Multimode OF			Wavelength	Singlemode OF
		50/125 or 62.5/125		50/125		
		OM1	OM2	OM3		
Attenuation coefficient (dBkm ⁻¹ max)	850nm	3,5			1310nm	1,0
	1300nm	1,5			1550nm	1,0
Modal bandwidth OFL (MHz.km min)	850nm	200	500	1500		
	1300nm	500	500	500		
Modal bandwidth LL (MHz.km min)	850nm	-	-	2000		
	1300nm	-	-	-		
Propagation delay (ns.m ⁻¹ max)	850nm	5			1310nm	5
	1300nm				1550nm	

Legacy OF

Legacy OF



AGENDA

Introduction

OF: Testing Philosophies
Duplex and SFF Testing

Break

Gigabit Ethernet
Launch Conditions

OTDR vs. LSPM

Conclusions

Close

Optical Power Budgets

Application			Optical Fibre			
			50/125 (OM2)		62.5/125 (OM1)	
Mb/s	Network	λ	Max. length (m)	OPB max. (dB)	Max. length (m)	OPB max. (dB)
4	Token Ring	850 nm	1857 ¹	8.0	2000	13.0
10	Ethernet		1514 ¹	6.8	2000	12.5
16	Token Ring		1857 ¹	8.0	2000	13.0
100	Ethernet	1300 nm	2000	6.0	2000	11.0
1000	Ethernet	850 nm	550	3.56	275	2.6
1000	Ethernet	1300 nm	550	2.35	550	2.35
10000	Ethernet	850 nm	82	1.80	33	1.60
10000	Ethernet	CWDM/850	300	2.46	300	2.46
			50/125 (OM3)			
10000	Ethernet	850 nm	300	2.59		

¹ Calculated values using 1.5dB of connecting hardware losses

AGENDA

- Introduction
- OF: Testing Philosophies
- Duplex and SFF Testing
- Break
- Gigabit Ethernet
- Launch Conditions
- OTDR vs. LSPM
- Conclusions
- Close

Measurement Error

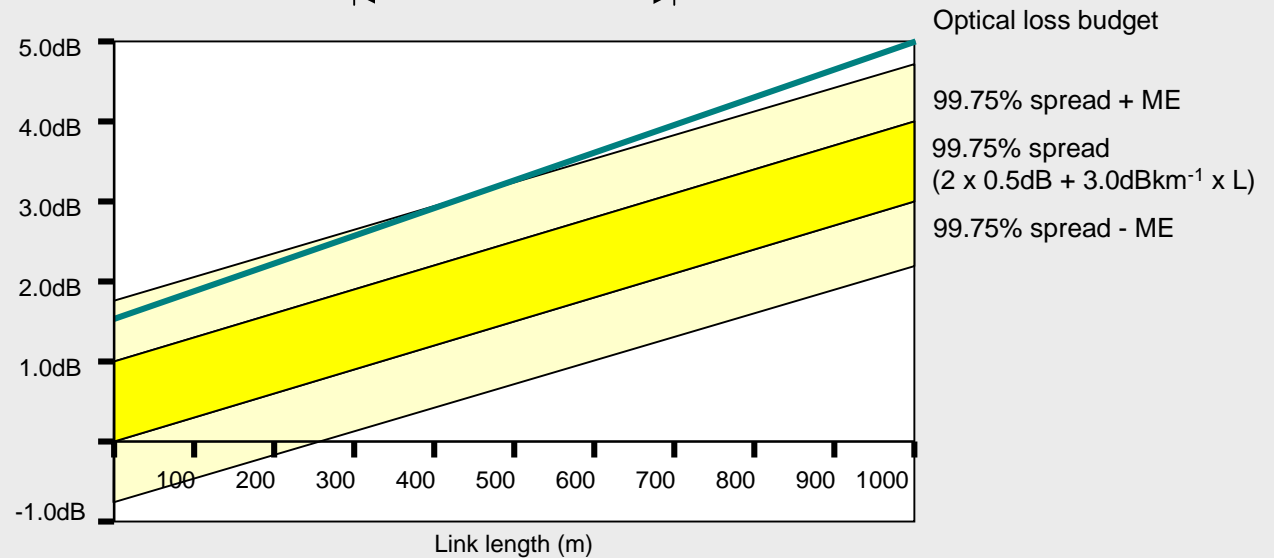
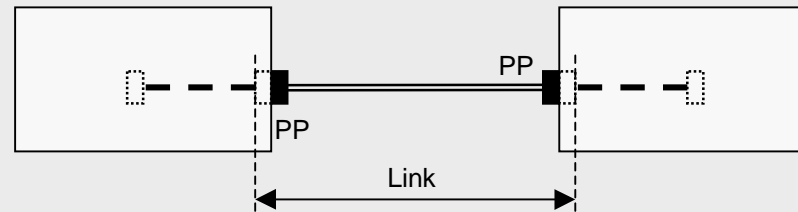

AGENDA

Introduction

OF: Testing Philosophies
Duplex and SFF Testing

Break

Gigabit Ethernet
Launch Conditions

OTDR vs. LSPM

Conclusions

Close

Typical Results

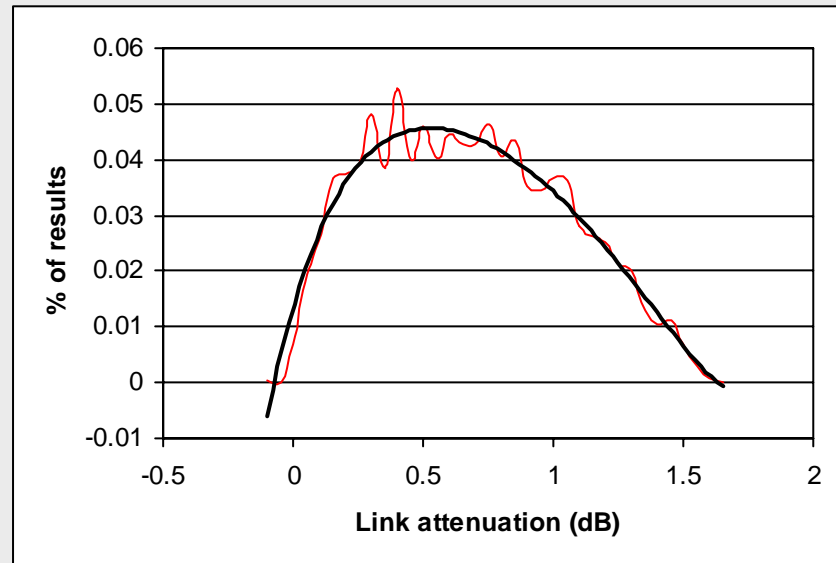

AGENDA

Introduction

OF: Testing Philosophies
Duplex and SFF Testing

Break

Gigabit Ethernet
Launch Conditions

OTDR vs. LSPM

Conclusions

Close

Pass/Fail Indicators

Test equipment that
not only
measures
but also
ADJUDICATES

Application support based upon:

- length (requiring the modal bandwidth of the optical fibre to be input);
- measured link/channel loss.

Cabling performance against calculation of optical loss budget based upon:

- number and type of joints
- length;
- measured link/channel loss.

**PASS/FAIL INDICATORS ARE VERY SUSCEPTIBLE
TO SHORT LENGTH SYNDROME
(measurement error)**

AGENDA

Introduction

OF: Testing Philosophies
Duplex and SFF Testing

Break

Gigabit Ethernet

Launch Conditions

OTDR vs. LSPM

Conclusions

Close

Test Cord Launch Conditions

MMF Mandrel Wrap

Cladding Mode Stripping

LASER LSPM Equipment

Launch Conditions

AGENDA

Introduction

OF: Testing Philosophies
Duplex and SFF Testing

Break

Gigabit Ethernet
Launch Conditions

OTDR vs. LSPM

Conclusions

Close

Test Cord Launch Conditions

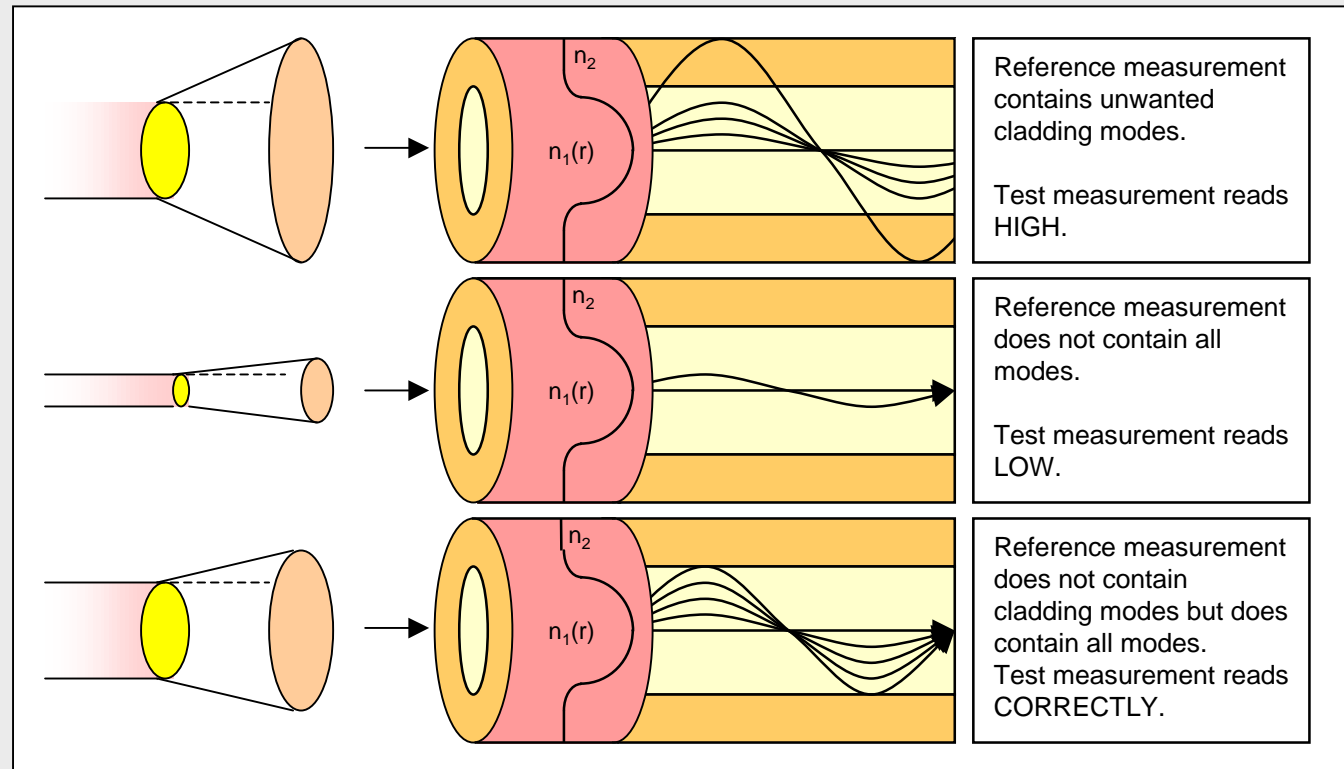



AGENDA

- Introduction
- OF: Testing Philosophies
- Duplex and SFF Testing
- Break
- Gigabit Ethernet
- Launch Conditions
- OTDR vs. LSPM
- Conclusions
- Close

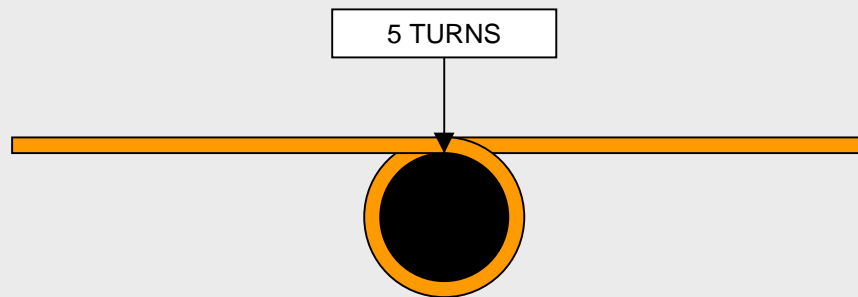
MMF Mandrel Wrap



	MMF: not applicable		MMF: EN 50346 6MP		MMF: ANSI/TIA/EIA B.1
			50/125 Cable 18		50/125 Cable 25
			50/125 SCOF 15		50/125 SCOF 22
			62.5/125 Cable 20		62.5/125 Cable 20
			62.5/125 SCOF 17		62.5/125 SCOF 17



AGENDA

- Introduction
- OF: Testing Philosophies
- Duplex and SFF Testing
- Break
- Gigabit Ethernet Launch Conditions
- OTDR vs. LSPM
- Conclusions
- Close

Cladding Mode Stripping

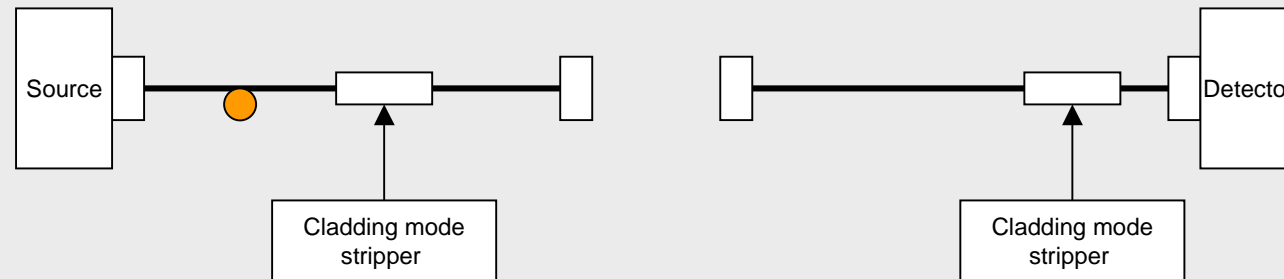

MMF LAUNCH CORD
Mandrel wrap and cladding mode stripper aim to present an equilibrium launch condition

MMF TAIL CORD
Cladding mode stripper provides "core only" light to detector
Removes requirement for bi-directional test

AGENDA

Introduction

OF: Testing Philosophies
Duplex and SFF Testing

Break

Gigabit Ethernet
Launch Conditions

OTDR vs. LSPM

Conclusions

Close

LASER LSPM Equipment

There is an argument to suggest that MMF cabling to support LASER-based applications should be tested with LASER sources

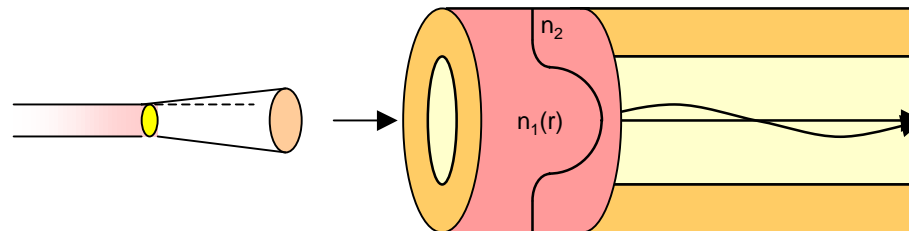

Reference measurement does not contain all modes.

Test measurement reads LOW.

Test results can vary with test lead handling.

Unless explicitly allowed and documented such equipment should not be used

AGENDA

Introduction

OF: Testing Philosophies
Duplex and SFF Testing

Break

Gigabit Ethernet
Launch Conditions

OTDR vs. LSPM

Conclusions

Close

OTDR vs. LSPM

SHORT LENGTH SYNDROME
calls LSPM measurements into question

(unless measurement error is "allowed for" in adjudication)

OTDRs can be used to assess and measure individual components
(subject to appropriate techniques)

COMPONENT UP VERIFICATION MAY BECOME MORE COMMON

AGENDA

Introduction

OF: Testing Philosophies
Duplex and SFF Testing

Break

Gigabit Ethernet
Launch Conditions

OTDR vs. LSPM

Conclusions

Close

FIA Documentation Update

DESIGN		
FIA-TSD-2000-1-1	OPTICAL FIBRE CABLING: LAN APPLICATION SUPPORT GUIDE	JANUARY 2001
	Revision to include mode conditioning cords and 10GBASE-xyz	JANUARY 2002
INSTALLATION		
FIA-TSD-2000-4-2-1	TESTING OF INSTALLED CABLING: ATTENUATION USING LSPM EQUIPMENT	JANUARY 2002
FIA-TSD-2000-4-2-2	TESTING OF INSTALLED CABLING: ATTENUATION USING OTDR EQUIPMENT	mid 2002
SAFETY		
FIA-TSD-2000-5-1	OPTICAL POWER: SAFETY LEVELS	DECEMBER 2001
FIA-TSD-2000-5-2	OPTICAL FIBRE: HANDLING OF PROCESSING CHEMICALS	
FIA-TSD-2000-5-3	OPTICAL FIBRE: DISPOSAL OF WASTE	

MODELLING TOOLS	
CABLING STRUCTURES COST MODEL	DECEMBER 2001

AGENDA

Introduction

OF: Testing Philosophies
Duplex and SFF Testing

Break

Gigabit Ethernet

Launch Conditions

OTDR vs. LSPM

Conclusions

Close

Conclusions

READ THE CABLING SPECIFICATION

KNOW YOUR LIMITS

- which standard?
- which issue?

UNDERSTAND THE MARGINS

- undertake a channel design review
- make sure the client understands it

PLAN FOR FAILURE

- can "FAIL"s be expected?
- under which conditions?
 - what happens next?
- agree process with client

TEST CORDS - TEST CORDS
TEST CORDS - TEST CORDS

Testing Multimode Optical Fibre Infrastructures

Prepared and delivered for



Bisham Abbey
18th October 2001