

The Great Escape

QUALITY ASSURANCE IN SUPPORT OF ISO/IEC 11801/EN 50173 (2002)

Prepared and delivered by The Cabling Partnership



The Building Centre, London
16th July 2002

AGENDA

- Introduction
- The Standards
- The Requirements
- Recognising the Problem
- Break
- The Problem Areas
- Quality Planning
- Question Time
- Lunch
- A Universal Quality Plan
- Break
- Inspection
- Test Methodology
- Management of Failure
- Question Time
- Close

Mike Gilmore

The Cabling Partnership
www.it-cabling.com
e-Ready Building
www.e-readybuilding.com
PO Box MT65, LEEDS, LS17 8YD, United Kingdom
Tel: +44 (0) 113 232 3721 Fax: +44 (0) 113 232 3724

Mike Gilmore		
 ISO/IEC JTC1 SC25 Secretary: WG3: Generic Cabling Member: Project Team: SOHO	 BSI Chairman TCT7/-/1: IT Cabling Chairman TCT7/-/3: IT Cabling	
 CENELEC Convenor: TC215 WG1: IT Cabling Convenor: TC215 WG1 PTIP	Fibreoptic Industry Association Standards Director Technical Director	

AGENDA

Introduction

The Standards

The Requirements

Recognising the Problem

Break

The Problem Areas

Quality Planning

Question Time

Lunch

A Universal Quality Plan

Break

Inspection

Test Methodology

Management of Failure

Question Time

Close

Agenda

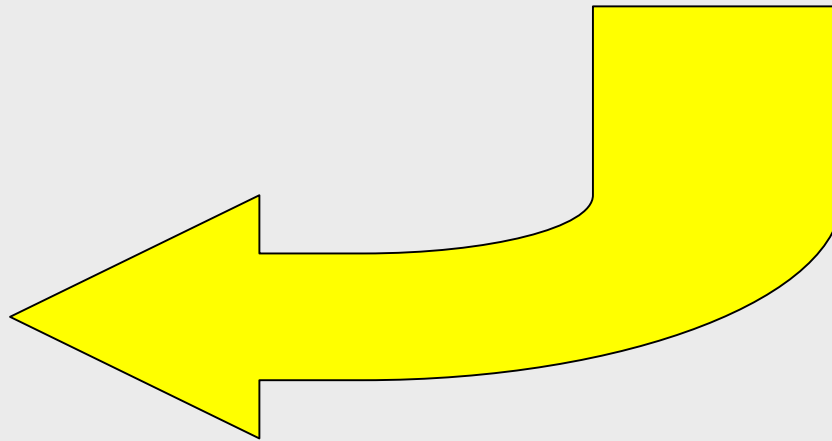

AGENDA

- Introduction
- The Standards
- The Requirements
- Recognising the Problem
- Break
- The Problem Areas
- Quality Planning
- Question Time
- Lunch
- A Universal Quality Plan
- Break
- Inspection
- Test Methodology
- Management of Failure
- Question Time
- Close

ISO, EN and US

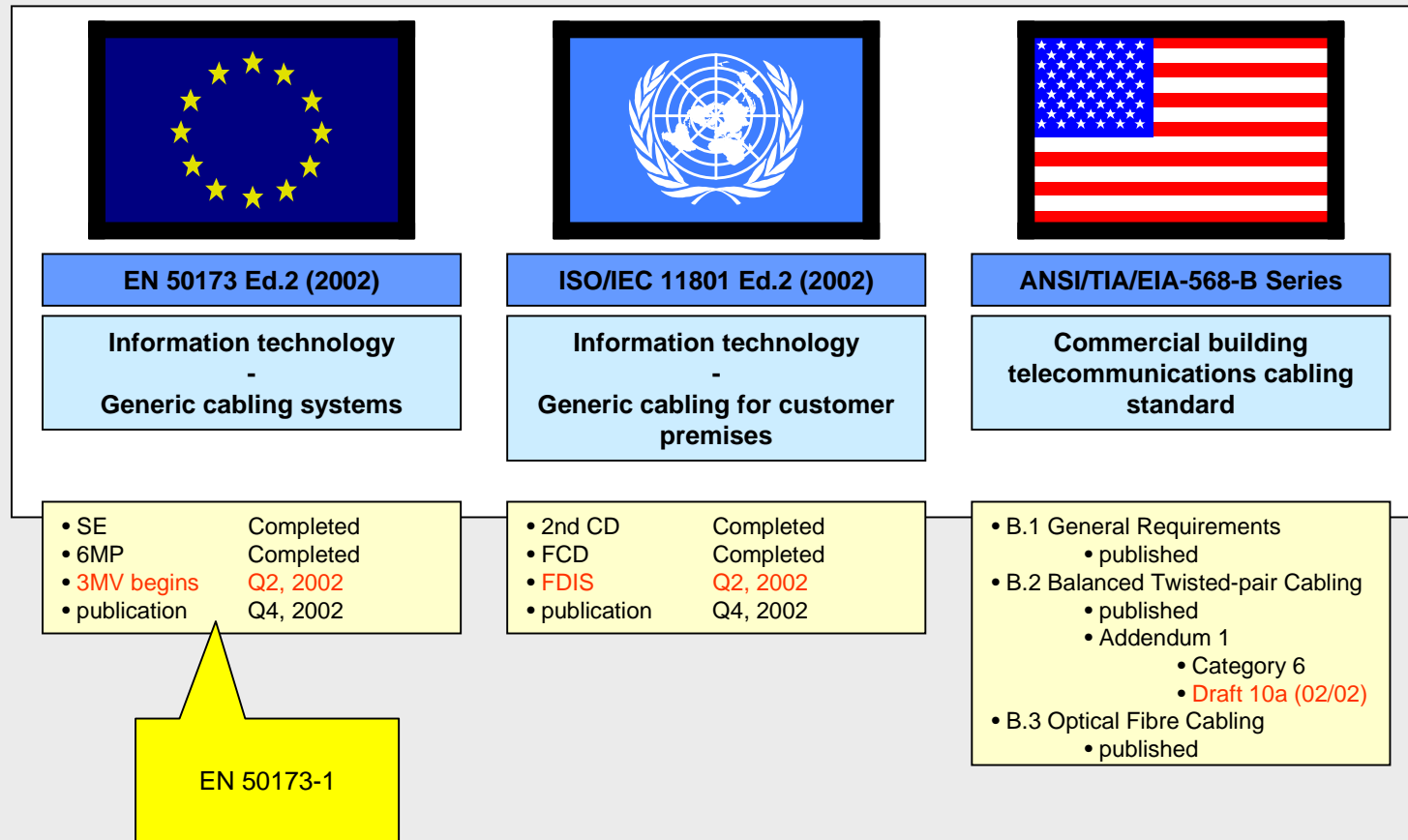

AGENDA

The Requirements

Introduction

The Standards

The Requirements

Recognising the Problem

Break

The Problem Areas

Quality Planning

Question Time

Lunch

A Universal Quality Plan

Break

Inspection

Test Methodology

Management of Failure

Question Time

Close

The Channel

Copper Channel Performance

Return Loss

Attenuation/insertion loss

NEXT/PSNEXT

ACR/PSACR

ELFEXT/PSELFEXT

Delay/Delay Skew

Power Feeding Parameters

Unbalance Attenuation

Permanent Link (2002)

CP Link

Copper Link Performance

Return Loss, NEXT and PSNEXT

ELFEXT/PSELFEXT

Loop Resistance, Delay, Delay Skew

Attenuation, ACR and PSACR

Optical Fibre Channel and Link Performance

AGENDA

- Introduction
- The Standards
- The Requirements
- Recognising the Problem
- Break
- The Problem Areas
- Quality Planning
- Question Time
- Lunch
- A Universal Quality Plan
- Break
- Inspection
- Test Methodology
- Management of Failure
- Question Time
- Close

The Channel

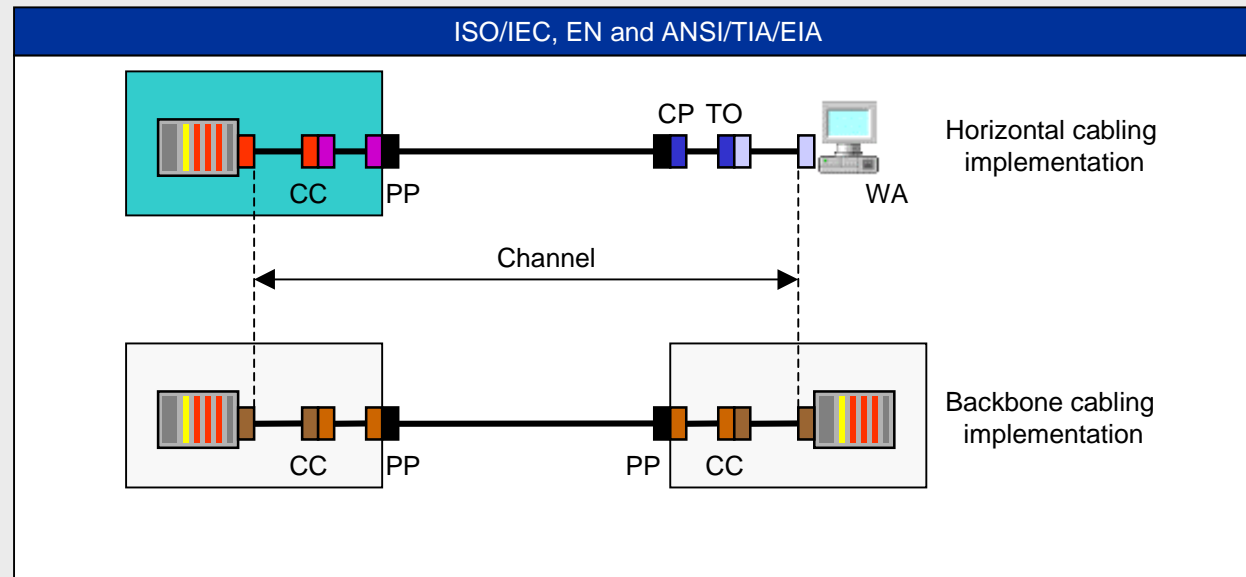

AGENDA

- Introduction
- The Standards
- The Requirements
- Recognising the Problem
- Break
- The Problem Areas
- Quality Planning
- Question Time
- Lunch
- A Universal Quality Plan
- Break
- Inspection
- Test Methodology
- Management of Failure
- Question Time
- Close

Return Loss

Class	Frequency	Minimum channel return loss (dB)
C	$1 \leq f \leq 16$	15,0
D	$1 \leq f \leq 100$	$30-10\log(f)$, 17,0 dB max.
E	$1 \leq f < 40$	$24-5\log(f)$, 19,0 dB max.
	$40 \leq f \leq 250$	$32-10\log(f)$
F	$1 \leq f < 40$	$24-5\log(f)$, 19,0 dB max.
	$40 \leq f \leq 600$	$32-10\log(f)$, 8,0 dB min.

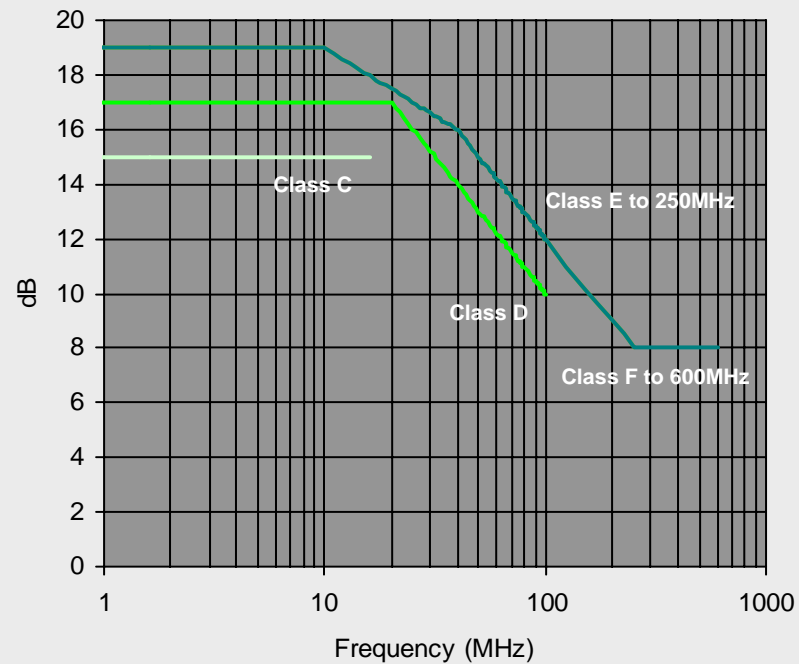

AGENDA

- Introduction
- The Standards
- The Requirements
- Recognising the Problem
- Break
- The Problem Areas
- Quality Planning
- Question Time
- Lunch
- A Universal Quality Plan
- Break
- Inspection
- Test Methodology
- Management of Failure
- Question Time
- Close

Attenuation/Insertion Loss

Class	Frequency	Maximum channel insertion loss (dB)
A	$f = 0.1$	16,0
B		5,5 @ 0,1 MHz 5,8 @ 1 MHz
C	$1 \leq f \leq 16$	$1,05 \cdot (3,23 \cdot \sqrt{f}) + 4 \cdot 0,2$
D	$1 \leq f \leq 100$	$1,05 \cdot (1,9108 \cdot \sqrt{f} + 0,0222 \cdot f + 0,2/\sqrt{f}) + 4 \cdot 0,04 \cdot \sqrt{f}$, 4dB min.
E	$1 \leq f \leq 250$	$1,05 \cdot (1,82 \cdot \sqrt{f} + 0,0169 \cdot f + 0,25/\sqrt{f}) + 4 \cdot 0,02 \cdot \sqrt{f}$, 4dB min.
F	$1 \leq f \leq 600$	$1,05 \cdot (1,80 \cdot \sqrt{f} + 0,010 \cdot f + 0,2/\sqrt{f}) + 4 \cdot 0,02 \cdot \sqrt{f}$, 4dB min.

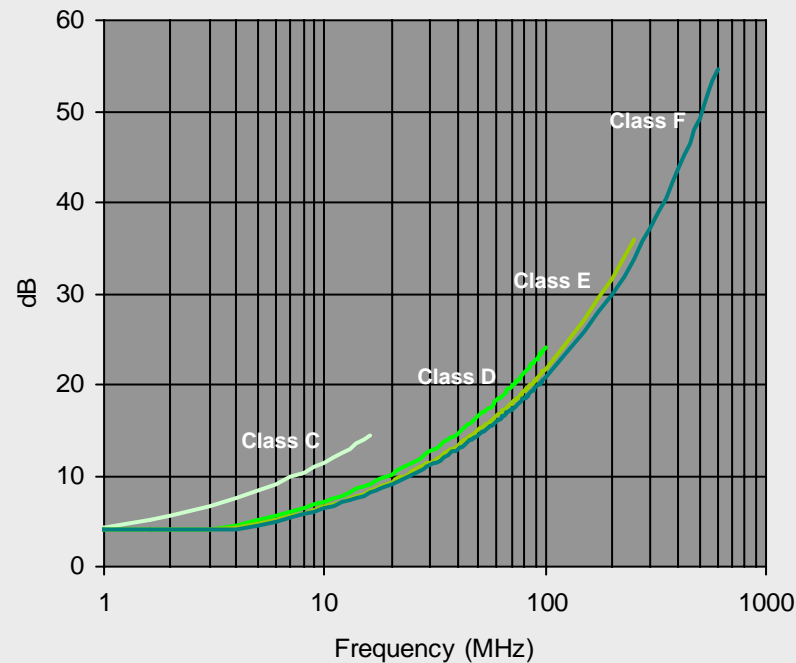

AGENDA

- Introduction
- The Standards
- The Requirements
- Recognising the Problem
- Break
- The Problem Areas
- Quality Planning
- Question Time
- Lunch
- A Universal Quality Plan
- Break
- Inspection
- Test Methodology
- Management of Failure
- Question Time
- Close

NEXT

Class	Frequency	Minimum channel NEXT (dB)
A	$f = 0.1$	27
B	$f \leq 1$	$25 - 15 \cdot \log(f)$
C	$1 \leq f \leq 16$	$39,1 - 16,4 \cdot \log(f)$
D	$1 \leq f \leq 100$	$-20 \cdot \log(10^{(-0,05 \cdot (65,3 - 15 \cdot \log(f)))} + 2 \cdot 10^{(-0,05 \cdot (83 - 20 \cdot \log(f)))})$, 60 dB max.
E	$1 \leq f \leq 250$	$-20 \cdot \log(10^{(-0,05 \cdot (74,3 - 15 \cdot \log(f)))} + 2 \cdot 10^{(-0,05 \cdot (94 - 20 \cdot \log(f)))})$, 65 dB max.
F	$1 \leq f \leq 600$	$-20 \cdot \log(10^{(-0,05 \cdot (102,4 - 15 \cdot \log(f)))} + 2 \cdot 10^{(-0,05 \cdot (102,4 - 15 \cdot \log(f)))})$, 65 dB max.

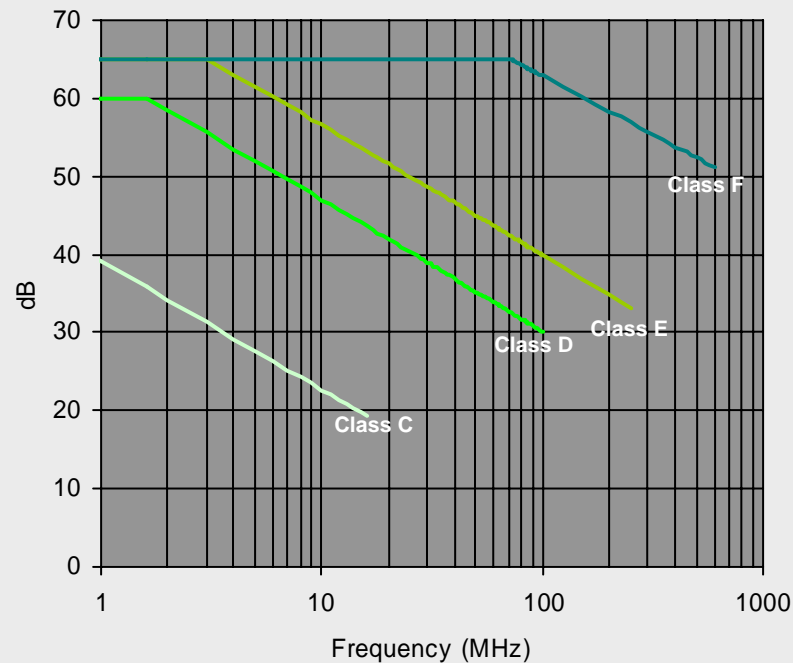

AGENDA

- Introduction
- The Standards
- The Requirements
- Recognising the Problem
- Break
- The Problem Areas
- Quality Planning
- Question Time
- Lunch
- A Universal Quality Plan
- Break
- Inspection
- Test Methodology
- Management of Failure
- Question Time
- Close

PSNEXT

Class	Frequency	Minimum channel PS NEXT (dB)
D	$1 \leq f \leq 100$	$-20 \cdot \log(10^{-0,05 \cdot (62,3 - 15 \cdot \log(f))}) + 2 \cdot 10^{-0,05 \cdot (80 - 20 \cdot \log(f))}$), 57 dB max.
E	$1 \leq f \leq 250$	$-20 \cdot \log(10^{-0,05 \cdot (72,3 - 15 \cdot \log(f))}) + 2 \cdot 10^{-0,05 \cdot (90 - 20 \cdot \log(f))}$), 62 dB max.
F	$1 \leq f \leq 600$	$-20 \cdot \log(10^{-0,05 \cdot (99,4 - 15 \cdot \log(f))}) + 2 \cdot 10^{-0,05 \cdot (99,4 - 15 \cdot \log(f))}$), 62 dB max.

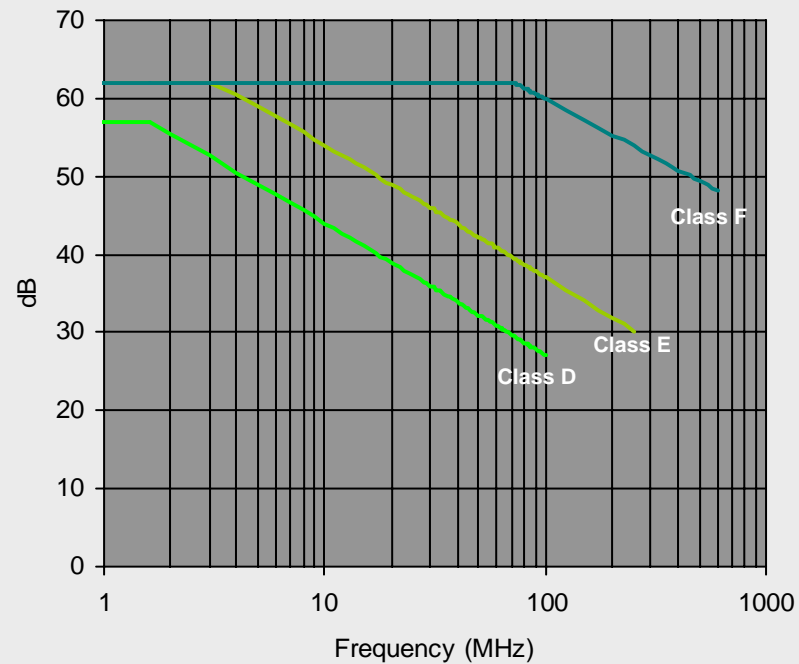

AGENDA

- Introduction
- The Standards
- The Requirements
- Recognising the Problem
- Break
- The Problem Areas
- Quality Planning
- Question Time
- Lunch
- A Universal Quality Plan
- Break
- Inspection
- Test Methodology
- Management of Failure
- Question Time
- Close

ACR

Class	Frequency	Minimum channel ACR (dB)
D	$1 \leq f \leq 100$	NEXT (channel) - attenuation/insertion loss (channel)
E	$1 \leq f \leq 250$	NEXT (channel) - attenuation/insertion loss (channel)
F	$1 \leq f \leq 600$	NEXT (channel) - attenuation/insertion loss (channel)

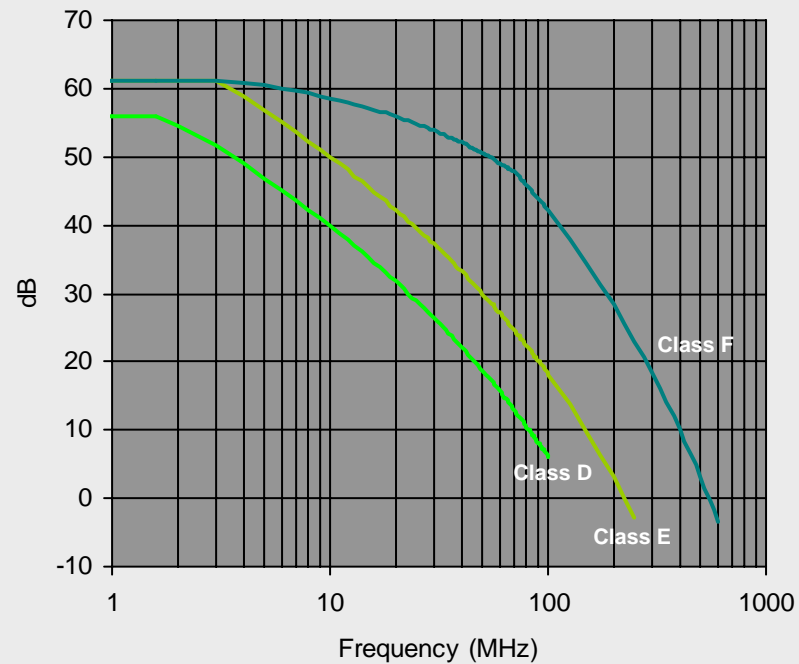

AGENDA

- Introduction
- The Standards
- The Requirements
- Recognising the Problem
- Break
- The Problem Areas
- Quality Planning
- Question Time
- Lunch
- A Universal Quality Plan
- Break
- Inspection
- Test Methodology
- Management of Failure
- Question Time
- Close

PSACR

Class	Frequency	Minimum channel PS ACR (dB)
D	$1 \leq f \leq 100$	PS NEXT (channel) - attenuation/insertion loss (channel)
E	$1 \leq f \leq 250$	PS NEXT (channel) - attenuation/insertion loss (channel)
F	$1 \leq f \leq 600$	PS NEXT (channel) - attenuation/insertion loss (channel)

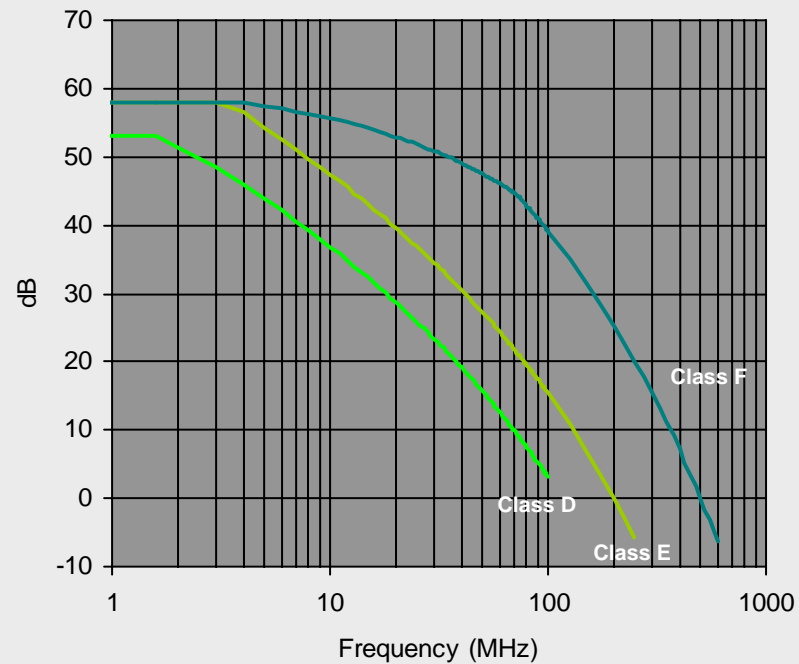

AGENDA

- Introduction
- The Standards
- The Requirements
- Recognising the Problem
- Break
- The Problem Areas
- Quality Planning
- Question Time
- Lunch
- A Universal Quality Plan
- Break
- Inspection
- Test Methodology
- Management of Failure
- Question Time
- Close

ELFEXT

Class	Frequency	Minimum channel ELFEXT (dB)
D	$1 \leq f \leq 100$	$-20 \cdot \log(10^{(-0,05 \cdot (63,8 - 20 \cdot \log(f)))} + 4 \cdot 10^{(-0,05 \cdot (75,1 - 20 \cdot \log(f)))})$, 60 dB max.
E	$1 \leq f \leq 250$	$-20 \cdot \log(10^{(-0,05 \cdot (67,8 - 20 \cdot \log(f)))} + 4 \cdot 10^{(-0,05 \cdot (83,1 - 20 \cdot \log(f)))})$, 65 dB max.
F	$1 \leq f \leq 600$	$-20 \cdot \log(10^{(-0,05 \cdot (94,0 - 20 \cdot \log(f)))} + 4 \cdot 10^{(-0,05 \cdot (90,0 - 15 \cdot \log(f)))})$, 65 dB max.

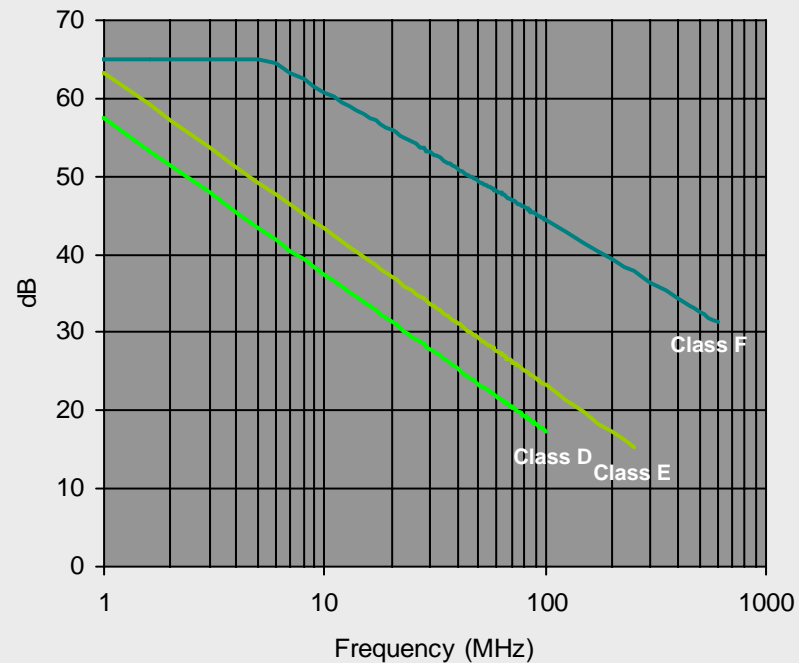

AGENDA

- Introduction
- The Standards
- The Requirements
- Recognising the Problem
- Break
- The Problem Areas
- Quality Planning
- Question Time
- Lunch
- A Universal Quality Plan
- Break
- Inspection
- Test Methodology
- Management of Failure
- Question Time
- Close

PSELFEXT

Class	Frequency	Minimum channel PS ELFEXT (dB)
D	$1 \leq f \leq 100$	$-20 \cdot \log(10^{(-0,05 \cdot (60,8 - 20 \cdot \log(f)))}) + 4 \cdot 10^{(-0,05 \cdot (72,1 - 20 \cdot \log(f)))}$, 60 dB max.
E	$1 \leq f \leq 250$	$-20 \cdot \log(10^{(-0,05 \cdot (64,8 - 20 \cdot \log(f)))}) + 4 \cdot 10^{(-0,05 \cdot (80,1 - 20 \cdot \log(f)))}$, 65 dB max.
F	$1 \leq f \leq 600$	$-20 \cdot \log(10^{(-0,05 \cdot (91,0 - 20 \cdot \log(f)))}) + 4 \cdot 10^{(-0,05 \cdot (87,0 - 15 \cdot \log(f)))}$, 65 dB max.

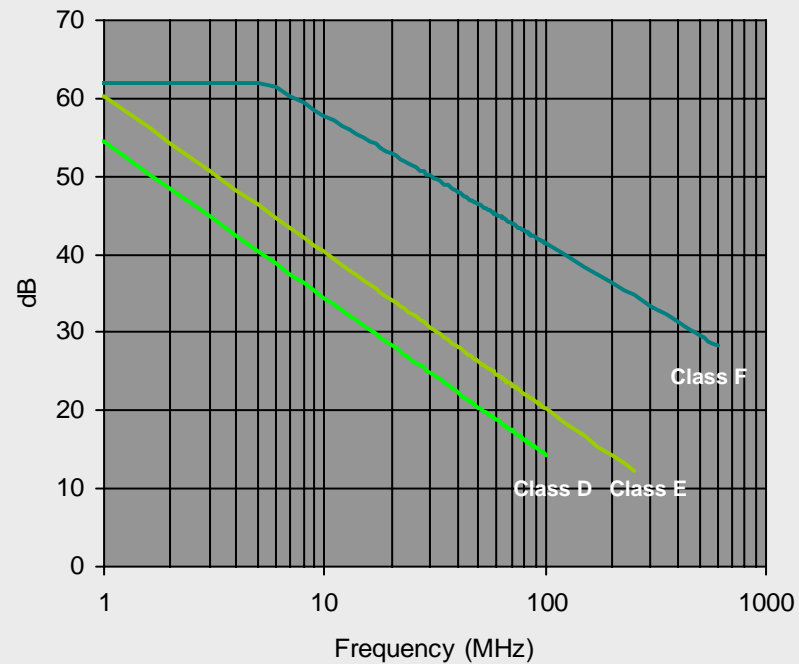

AGENDA

- Introduction
- The Standards
- The Requirements
- Recognising the Problem
- Break
- The Problem Areas
- Quality Planning
- Question Time
- Lunch
- A Universal Quality Plan
- Break
- Inspection
- Test Methodology
- Management of Failure
- Question Time
- Close

Delay/Delay Skew

Class	Frequency	Maximum channel propagation delay (µs)
A	f = 0.1	20,000
B	f ≤ 1	5,000
C	1 ≤ f ≤ 16	0,534 + 0,036/sqrt(f) + 4 * 0,0025
D	1 ≤ f ≤ 100	0,534 + 0,036/sqrt(f) + 4 * 0,0025
E	1 ≤ f ≤ 250	0,534 + 0,036/sqrt(f) + 4 * 0,0025
F	1 ≤ f ≤ 600	0,534 + 0,036/sqrt(f) + 4 * 0,0025

Class	Frequency	Maximum channel delay skew (µs)
D	1 ≤ f ≤ 100	0,045 + 4 * 0,00125 = 0,050
E	1 ≤ f ≤ 250	0,045 + 4 * 0,00125 = 0,050
F	1 ≤ f ≤ 600	0,025 + 4 * 0,00125 = 0,030

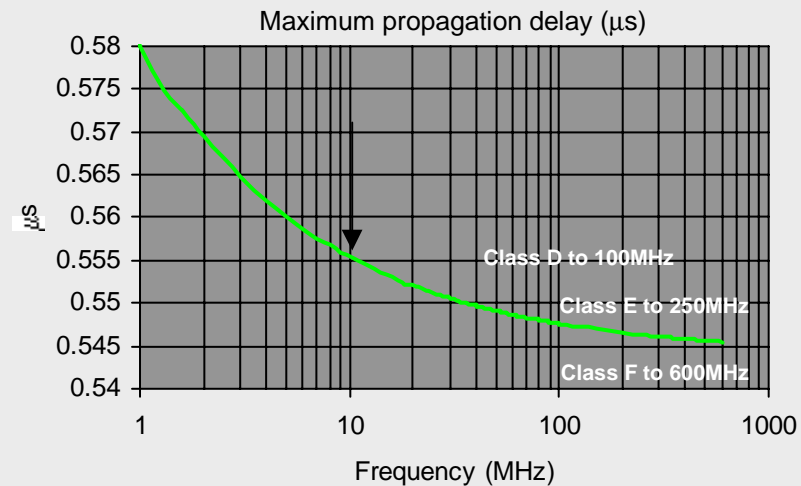

AGENDA

Introduction
The Standards
The Requirements
Recognising the Problem
Break
The Problem Areas
Quality Planning
Question Time
Lunch
A Universal Quality Plan
Break
Inspection
Test Methodology
Management of Failure
Question Time
Close

Power Feeding Parameters

Class	Frequency	Maximum channel loop resistance (ohm)
A	d.c.	560
B	d.c.	170
C	d.c.	40
D	d.c.	25
E	d.c.	25
F	d.c.	25

Class	Frequency	Max. channel resistance unbalance (%) within a pair
D	d.c.	3
E	d.c.	3
F	d.c.	3

Class	Frequency	Min. channel current carrying capacity (A)
D	d.c.	0,175 per conductor
E	d.c.	0,175 per conductor
F	d.c.	0,175 per conductor

Class	Frequency	Min. channel power capacity per pair (W)
D	d.c.	10
E	d.c.	10
F	d.c.	10

Class	Frequency	Min. operating voltage (V)
D	d.c.	72
E	d.c.	72
F	d.c.	72

AGENDA

Introduction

The Standards

The Requirements

Recognising the Problem

Break

The Problem Areas

Quality Planning

Question Time

Lunch

A Universal Quality Plan

Break

Inspection

Test Methodology

Management of Failure

Question Time

Close

Unbalance Attenuation

Class	Frequency	Maximum channel loop resistance (ohm)
A	d.c.	30
B	d.c.	45 @ 0,1 MHz; 20 @ 1 MHz
C	d.c.	30 - 5 log(f) ffs
D	d.c.	40 - 10 log(f) ffs
E	d.c.	40 - 10 log(f) ffs
F	d.c.	40 - 10 log(f) ffs

AGENDA

- Introduction
- The Standards
- The Requirements
- Recognising the Problem
- Break
- The Problem Areas
- Quality Planning
- Question Time
- Lunch
- A Universal Quality Plan
- Break
- Inspection
- Test Methodology
- Management of Failure
- Question Time
- Close

Permanent Link (2002)

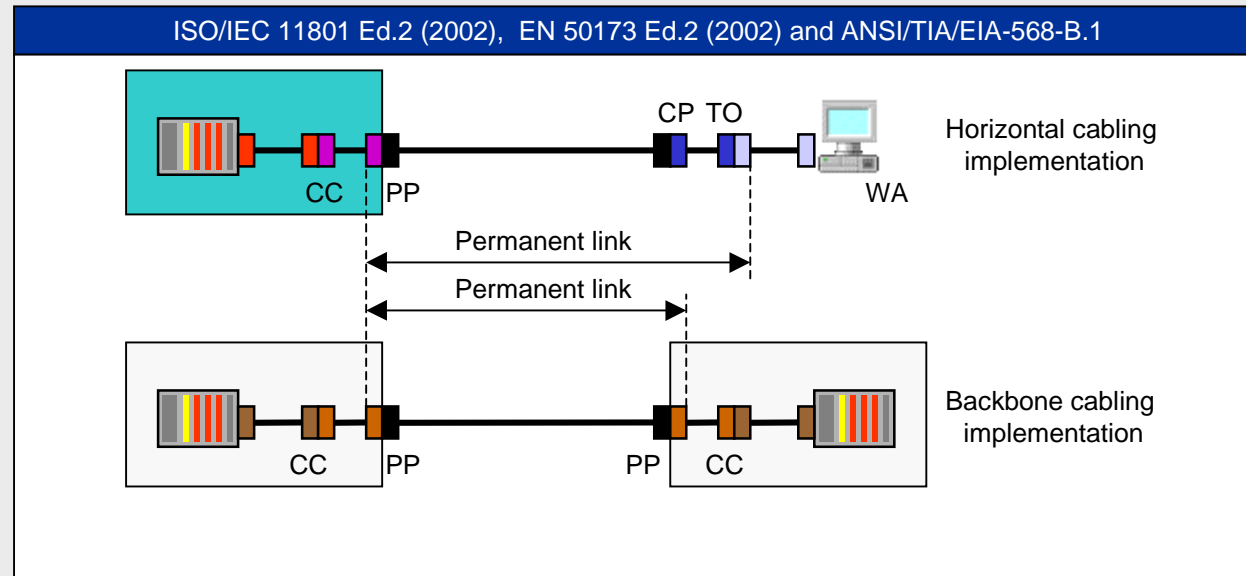

AGENDA

- Introduction
- The Standards
- The Requirements
- Recognising the Problem
- Break
- The Problem Areas
- Quality Planning
- Question Time
- Lunch
- A Universal Quality Plan
- Break
- Inspection
- Test Methodology
- Management of Failure
- Question Time
- Close

CP Link

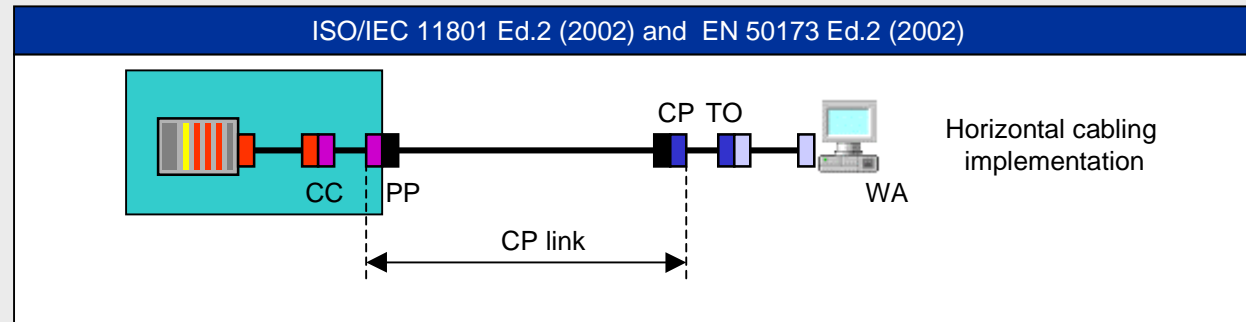

AGENDA

- Introduction
- The Standards
- The Requirements
- Recognising the Problem
- Break
- The Problem Areas
- Quality Planning
- Question Time
- Lunch
- A Universal Quality Plan
- Break
- Inspection
- Test Methodology
- Management of Failure
- Question Time
- Close

RL, NEXT and PSNEXT

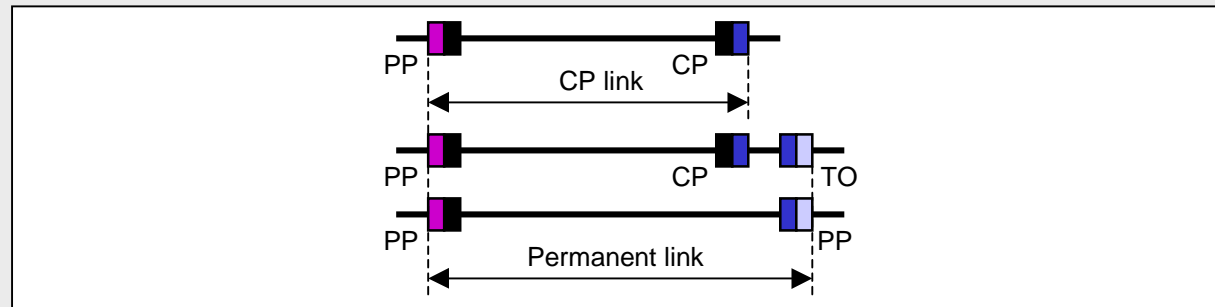

Class	Frequency	Minimum link return loss (dB)
C	$1 \leq f \leq 16$	15,0
D	$1 \leq f \leq 100$	$32-10\log(f)$, 19,0 dB max.
E	$1 \leq f < 40$	$26-5\log(f)$, 21,0 dB max.
	$40 \leq f \leq 250$	$34-10\log(f)$
F	$1 \leq f < 40$	$26-5\log(f)$, 21,0 dB max.
	$40 \leq f \leq 600$	$34-10\log(f)$, 10,0 dB min.

Class	Frequency	Minimum link NEXT (dB)
A	$f = 0.1$	27
B	$f \leq 1$	$25-15*\log(f)$
C	$1 \leq f \leq 16$	$40,1-15,8*\log(f)$
D	$1 \leq f \leq 100$	$-20*\log(10^{(-0,05*(65,3-15*\log(f))})+10^{(-0,05*(83-20*\log(f))}))$, 60 dB max.
E	$1 \leq f \leq 250$	$-20*\log(10^{(-0,05*(74,3-15*\log(f))})+10^{(-0,05*(94-20*\log(f))}))$, 65 dB max.
F	$1 \leq f \leq 600$	$-20*\log(10^{(-0,05*(102,4-15*\log(f))})+10^{(-0,05*(102,4-15*\log(f))}))$, 65 dB max.

Class	Frequency	Minimum link PS NEXT (dB)
D	$1 \leq f \leq 100$	$-20*\log(10^{(-0,05*(62,3-15*\log(f))})+10^{(-0,05*(80-20*\log(f))}))$, 57 dB max.
E	$1 \leq f \leq 250$	$-20*\log(10^{(-0,05*(72,3-15*\log(f))})+10^{(-0,05*(90-20*\log(f))}))$, 62 dB max.
F	$1 \leq f \leq 600$	$-20*\log(10^{(-0,05*(99,4-15*\log(f))})+10^{(-0,05*(99,4-15*\log(f))}))$, 62 dB max.

AGENDA

- Introduction
- The Standards
- The Requirements
- Recognising the Problem
- Break
- The Problem Areas
- Quality Planning
- Question Time
- Lunch
- A Universal Quality Plan
- Break
- Inspection
- Test Methodology
- Management of Failure
- Question Time
- Close

ELFEXT and PSELFEXT

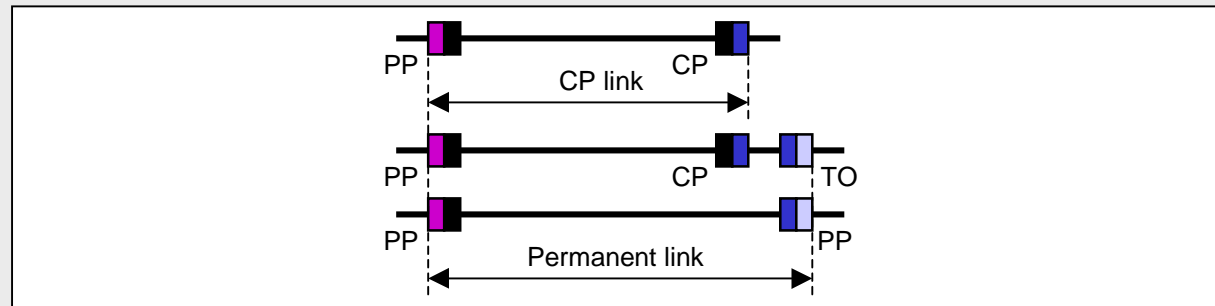

Class	Frequency	Minimum link ELFEXT (dB)
D	$1 \leq f \leq 100$	$-20 \cdot \log(10^{(-0,05 \cdot (63,8 - 20 \cdot \log(f)))} + n \cdot 10^{(-0,05 \cdot (75,1 - 20 \cdot \log(f)))})$, 60 dB max.
E	$1 \leq f \leq 250$	$-20 \cdot \log(10^{(-0,05 \cdot (67,8 - 20 \cdot \log(f)))} + n \cdot 10^{(-0,05 \cdot (83,1 - 20 \cdot \log(f)))})$, 65 dB max.
F	$1 \leq f \leq 600$	$-20 \cdot \log(10^{(-0,05 \cdot (94,0 - 20 \cdot \log(f)))} + n \cdot 10^{(-0,05 \cdot (90,0 - 15 \cdot \log(f)))})$, 65 dB max.

n = number of connections within the link

Class	Frequency	Minimum link PS ELFEXT (dB)
D	$1 \leq f \leq 100$	$-20 \cdot \log(10^{(-0,05 \cdot (60,8 - 20 \cdot \log(f)))} + n \cdot 10^{(-0,05 \cdot (72,1 - 20 \cdot \log(f)))})$, 60 dB max.
E	$1 \leq f \leq 250$	$-20 \cdot \log(10^{(-0,05 \cdot (64,8 - 20 \cdot \log(f)))} + n \cdot 10^{(-0,05 \cdot (80,1 - 20 \cdot \log(f)))})$, 65 dB max.
F	$1 \leq f \leq 600$	$-20 \cdot \log(10^{(-0,05 \cdot (91,0 - 20 \cdot \log(f)))} + n \cdot 10^{(-0,05 \cdot (87,0 - 15 \cdot \log(f)))})$, 65 dB max.

n = number of connections within the link

AGENDA

- Introduction
- The Standards
- The Requirements
- Recognising the Problem
- Break
- The Problem Areas
- Quality Planning
- Question Time
- Lunch
- A Universal Quality Plan
- Break
- Inspection
- Test Methodology
- Management of Failure
- Question Time
- Close

Loop Resistance, Delay, Delay Skew

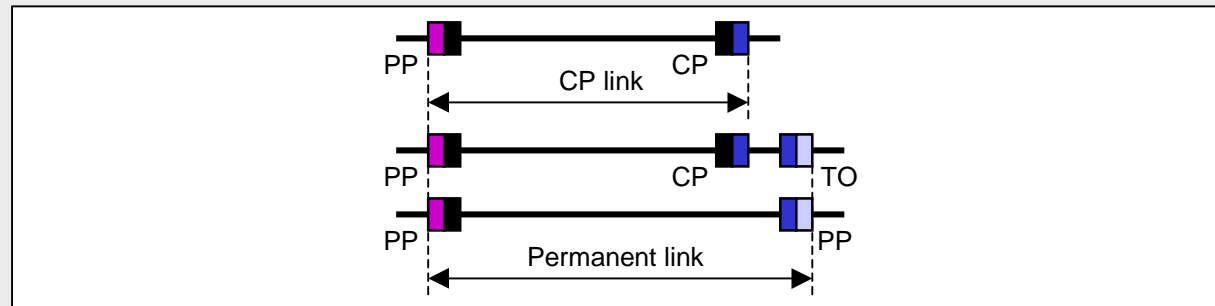

Class	Frequency	Max. link loop resistance (Ω)
D	d.c.	$(L/100)*22 + n*0,4$
E	d.c.	
F	d.c.	

n = number of connections within the link
 $L(m) = L_{FC} + L_{CP} * Y$ where
 L_{FC} = length of fixed cable and L_{CP} = length of CP cord
 Y = attenuation premium for the CP cable/cord.

Class	Frequency	Max. link propagation delay (μs)
D	$1 \leq f \leq 100$	$(L/100)*(0,534 + 0,036/\sqrt{f}) + n*0,0025$
E	$1 \leq f \leq 250$	$(L/100)*(0,534 + 0,036/\sqrt{f}) + n*0,0025$
F	$1 \leq f \leq 600$	$(L/100)*(0,534 + 0,036/\sqrt{f}) + n*0,0025$

Class	Frequency	Max. link delay skew (μs)
D	$1 \leq f \leq 100$	$(L/100)*0,045 + n*0,00125$
E	$1 \leq f \leq 250$	$(L/100)*0,045 + n*0,00125$
F	$1 \leq f \leq 600$	$(L/100)*0,025 + n*0,00125$

n = number of connections within the link
 $L(m) = L_{FC} + L_{CP}$ where L_{FC} = length of fixed cable, L_{CP} = length of CP cord.

AGENDA

- Introduction
- The Standards
- The Requirements
- Recognising the Problem
- Break
- The Problem Areas
- Quality Planning
- Question Time
- Lunch
- A Universal Quality Plan
- Break
- Inspection
- Test Methodology
- Management of Failure
- Question Time
- Close

Attenuation, ACR and PSACR

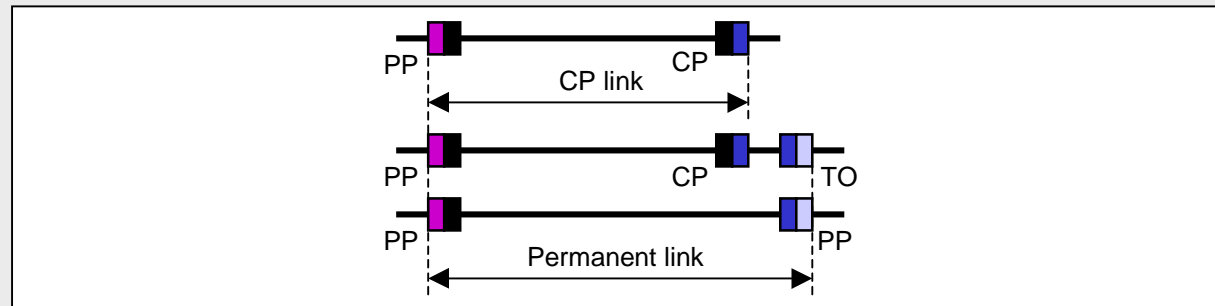

Class	Frequency	Maximum link insertion loss (dB)
D	$1 \leq f \leq 100$	$(L/100) * (1,9108 * \sqrt{f} + 0,0222 * f + 0,2 / \sqrt{f}) + n * 0,04 * \sqrt{f}$, 4dB min.
E	$1 \leq f \leq 250$	$(L/100) * (1,82 * \sqrt{f} + 0,0169 * f + 0,25 / \sqrt{f}) + n * 0,02 * \sqrt{f}$, 4dB min.
F	$1 \leq f \leq 600$	$(L/100) * (1,80 * \sqrt{f} + 0,010 * f + 0,2 / \sqrt{f}) + n * 0,02 * \sqrt{f}$, 4dB min.

n = number of connections within the link

$$L(m) = L_{FC} + L_{CP} * Y \text{ where}$$

L_{FC} = length of fixed cable and L_{CP} = length of CP cord,

Y = attenuation premium for the CP cable/cord.

Class	Frequency	Minimum link ACR (dB)
D	$1 \leq f \leq 100$	NEXT (link) - attenuation (link)
E	$1 \leq f \leq 250$	NEXT (link) - attenuation (link)
F	$1 \leq f \leq 600$	NEXT (link) - attenuation (link)

Class	Frequency	Minimum link PS ACR (dB)
D	$1 \leq f \leq 100$	PSNEXT (link) - attenuation (link)
E	$1 \leq f \leq 250$	PSNEXT (link) - attenuation (link)
F	$1 \leq f \leq 600$	PSNEXT (link) - attenuation (link)

AGENDA

- Introduction
- The Standards
- The Requirements
- Recognising the Problem
- Break
- The Problem Areas
- Quality Planning
- Question Time
- Lunch
- A Universal Quality Plan
- Break
- Inspection
- Test Methodology
- Management of Failure
- Question Time
- Close

Optical Fibre

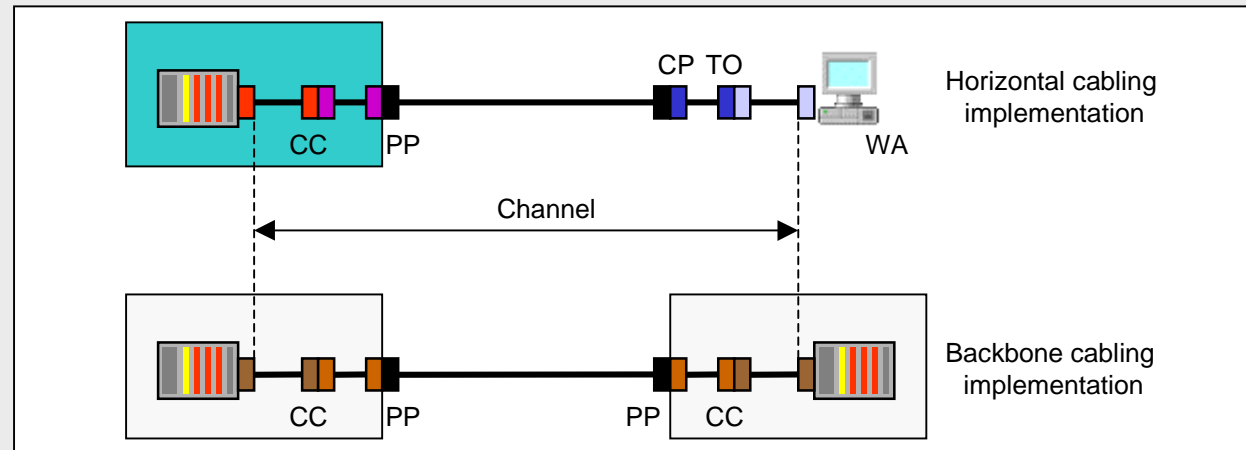

Channel requirements	Class	Maximum length (m)	Maximum attenuation (dB)			
			Multimode		Singlemode	
			850 nm	1300 nm	1310 nm	1550 nm
	OF-300	300	2,55	1,95	1,80	1,80
	OF-500	500	3,25	2,25	2,00	2,00
	OF-2000	2000	8,50	4,50	3,50	3,50

Link requirements		λ	Maximum attenuation (dB)
		Multimode	850nm
		1300nm	$0,0015 * L + 0.75 * n$
Singlemode		1310nm	$0,001 * L + 0.75 * n$
		1550nm	$0,001 * L + 0.75 * n$

n = number of connections within the link
L(m) = link length

AGENDA

Introduction

The Standards

The Requirements

Recognising the Problem

Break

The Problem Areas

Quality Planning

Question Time

Lunch

A Universal Quality Plan

Break

Inspection

Test Methodology

Management of Failure

Question Time

Close

Recognising the Problem

Conformance

Structure

Connecting Hardware at the TO

Other Connecting Hardware

Channel Performance

The Great Escape

AGENDA

Introduction

The Standards

The Requirements

Recognising the Problem

Break

The Problem Areas

Quality Planning

Question Time

Lunch

A Universal Quality Plan

Break

Inspection

Test Methodology

Management of Failure

Question Time

Close

Conformance

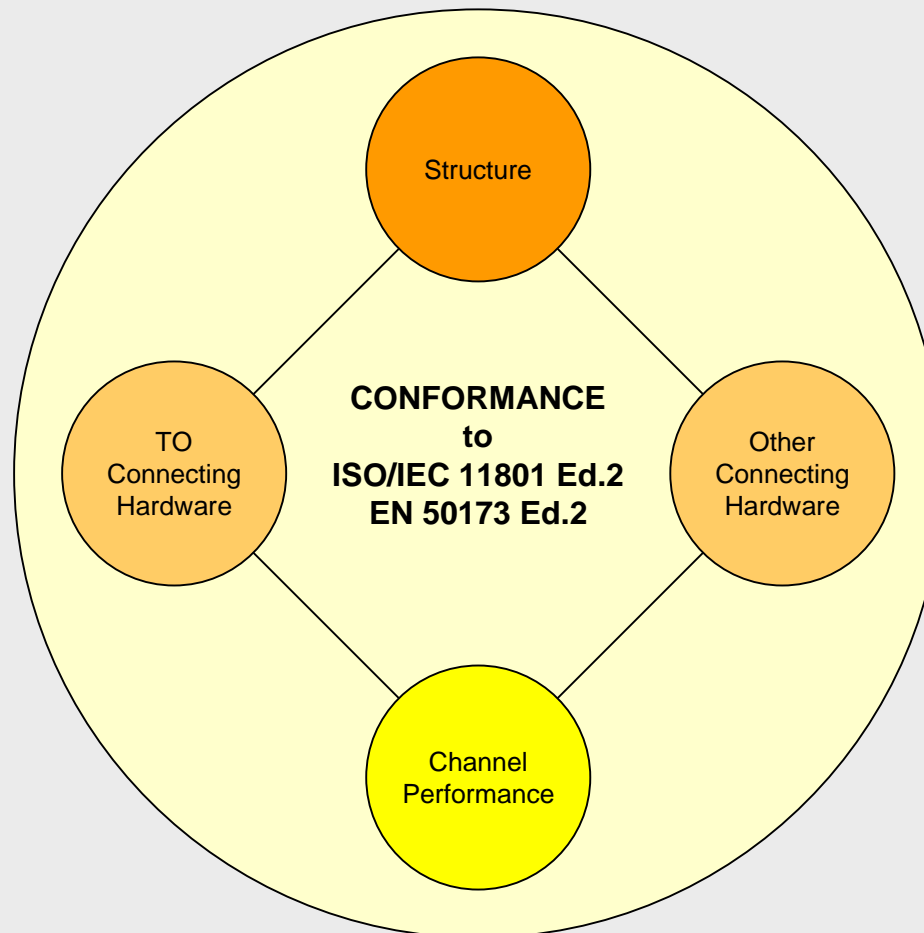

AGENDA

- Introduction
- The Standards
- The Requirements
- Recognising the Problem
- Break
- The Problem Areas
- Quality Planning
- Question Time
- Lunch
- A Universal Quality Plan
- Break
- Inspection
- Test Methodology
- Management of Failure
- Question Time
- Close

Structure

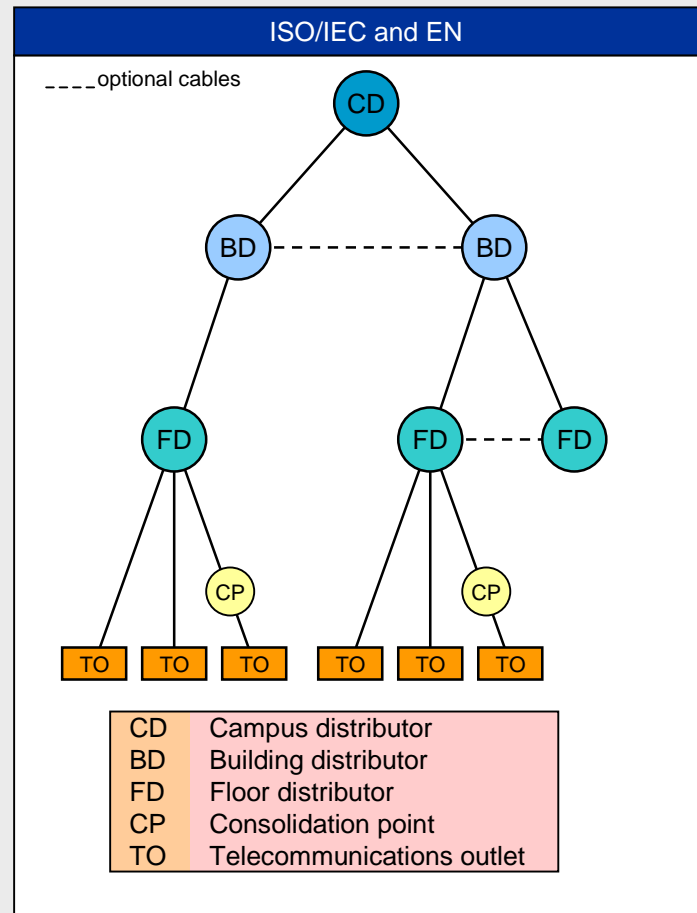

AGENDA

- Introduction
- The Standards
- The Requirements
- Recognising the Problem
- Break
- The Problem Areas
- Quality Planning
- Question Time
- Lunch
- A Universal Quality Plan
- Break
- Inspection
- Test Methodology
- Management of Failure
- Question Time
- Close

Connecting Hardware at the TO

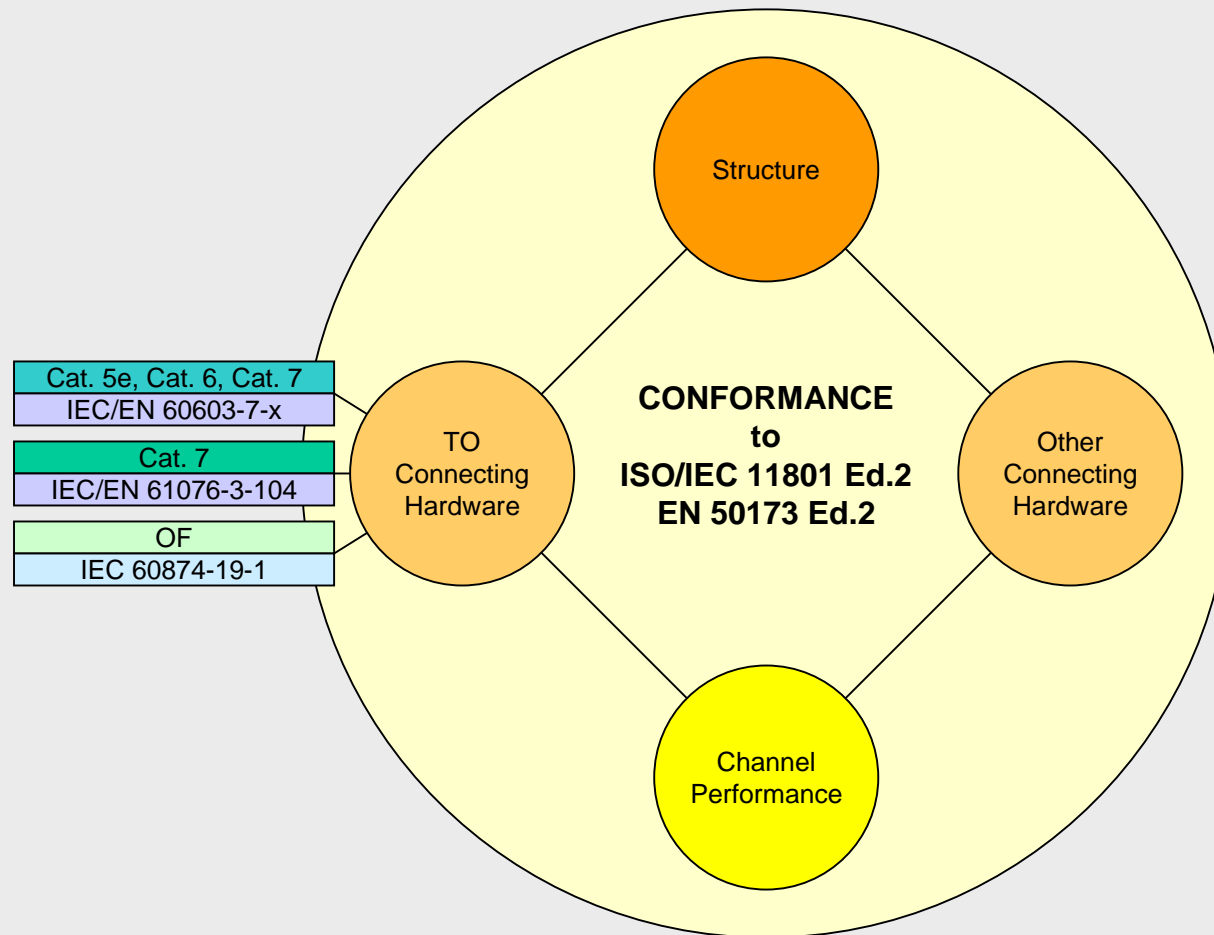

AGENDA

- Introduction
- The Standards
- The Requirements
- Recognising the Problem
- Break
- The Problem Areas
- Quality Planning
- Question Time
- Lunch
- A Universal Quality Plan
- Break
- Inspection
- Test Methodology
- Management of Failure
- Question Time
- Close

Other Connecting Hardware

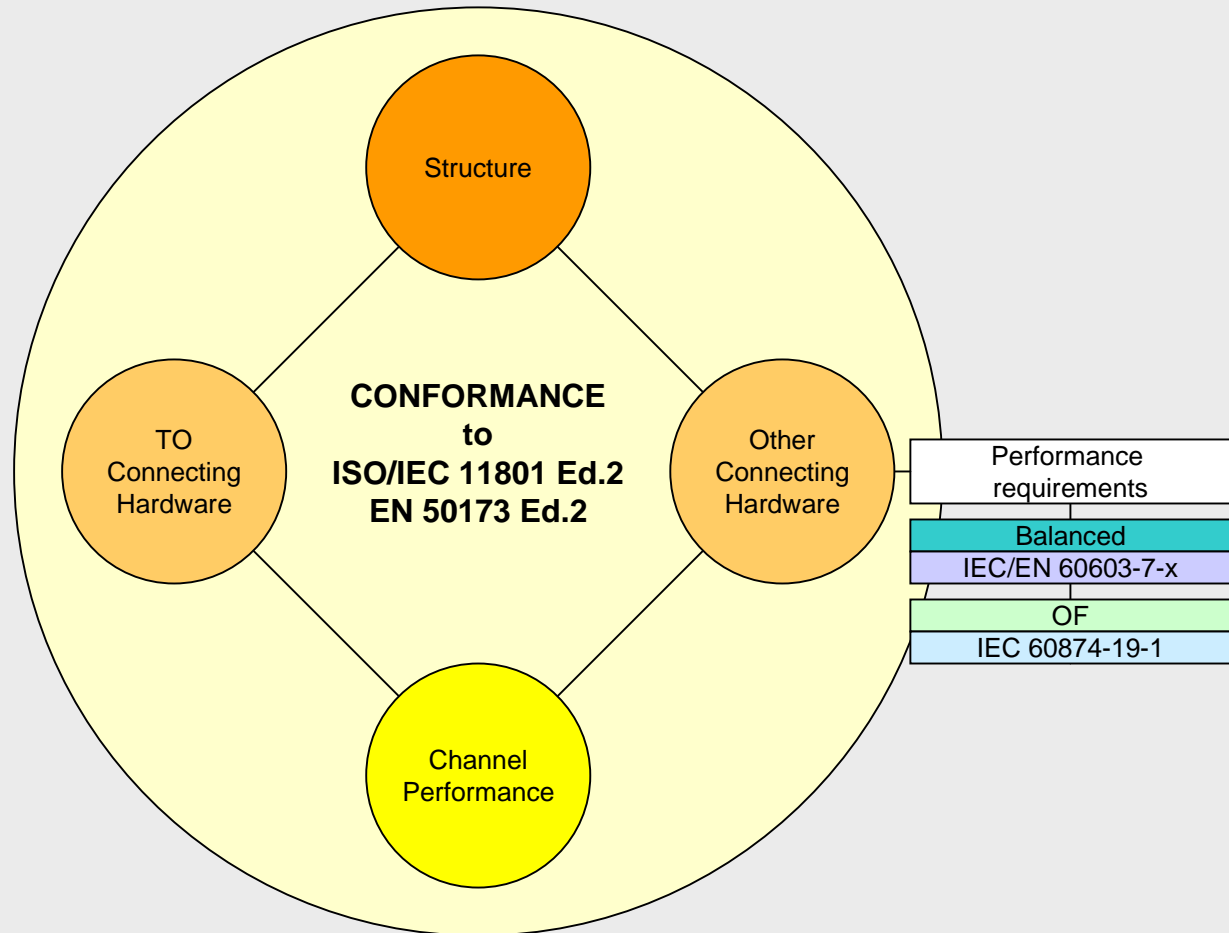

AGENDA

Introduction

The Standards

The Requirements

Recognising the Problem

Break

The Problem Areas

Quality Planning

Question Time

Lunch

A Universal Quality Plan

Break

Inspection

Test Methodology

Management of Failure

Question Time

Close

Channel Performance

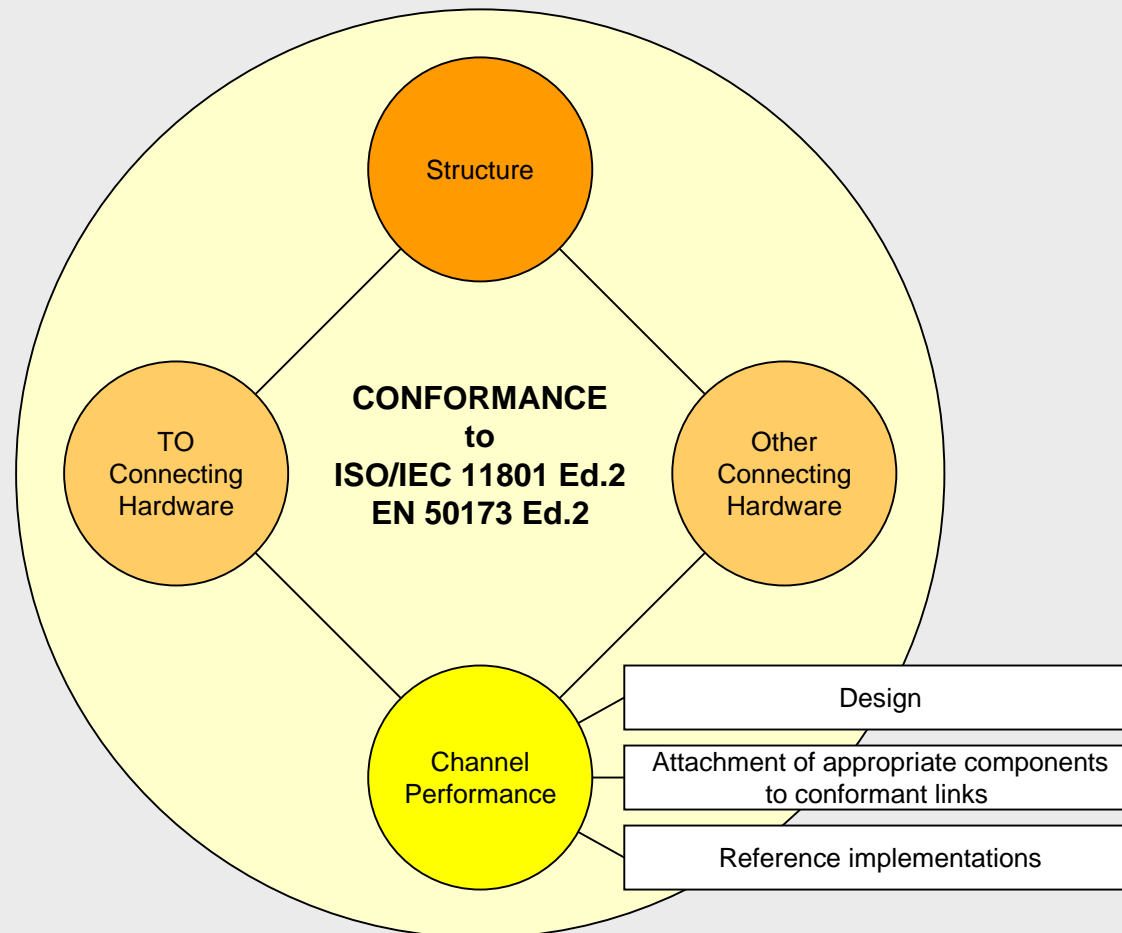

AGENDA

- Introduction
- The Standards
- The Requirements
- Recognising the Problem
- Break
- The Problem Areas
- Quality Planning
- Question Time
- Lunch
- A Universal Quality Plan
- Break
- Inspection
- Test Methodology
- Management of Failure
- Question Time
- Close

The Great Escape - Part 1

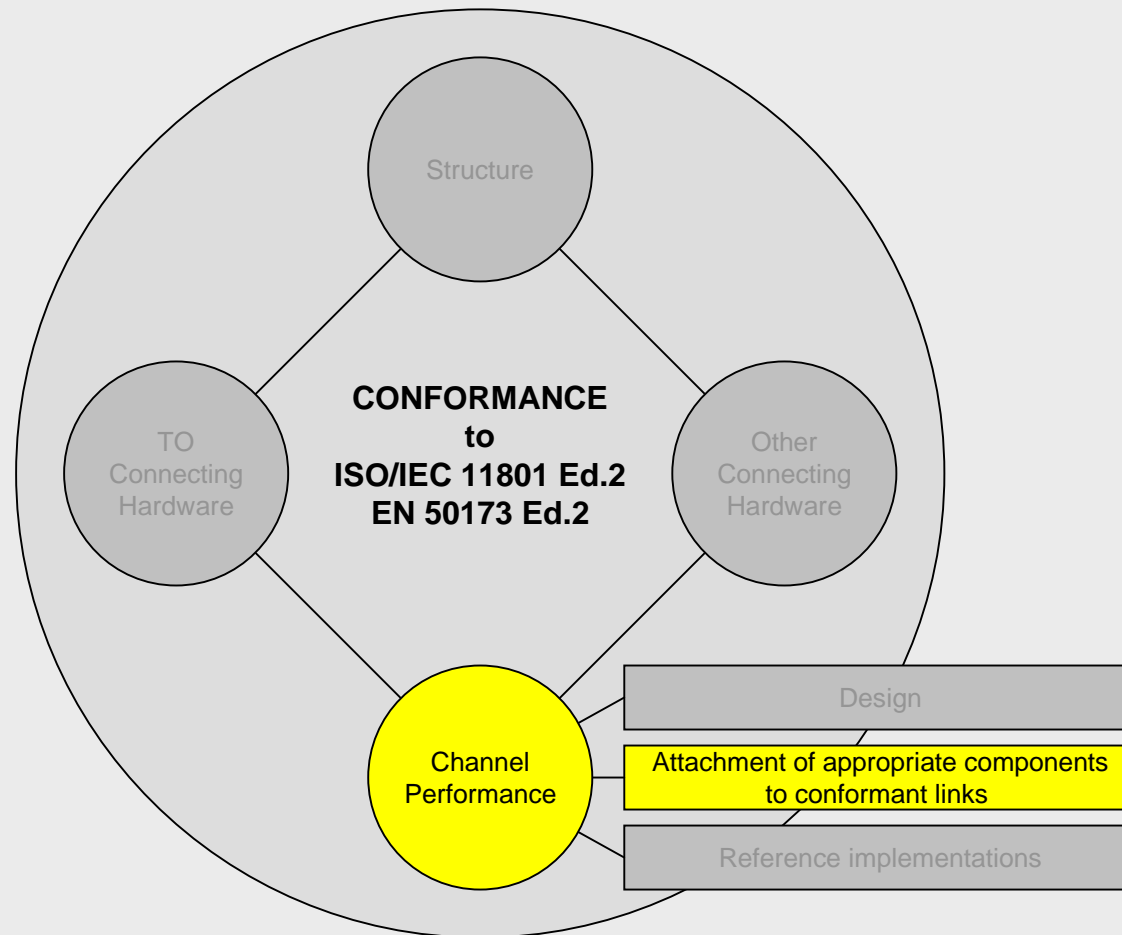

AGENDA

- Introduction
- The Standards
- The Requirements
- Recognising the Problem
- Break
- The Problem Areas
- Quality Planning
- Question Time
- Lunch
- A Universal Quality Plan
- Break
- Inspection
- Test Methodology
- Management of Failure
- Question Time
- Close

Appropriate Components

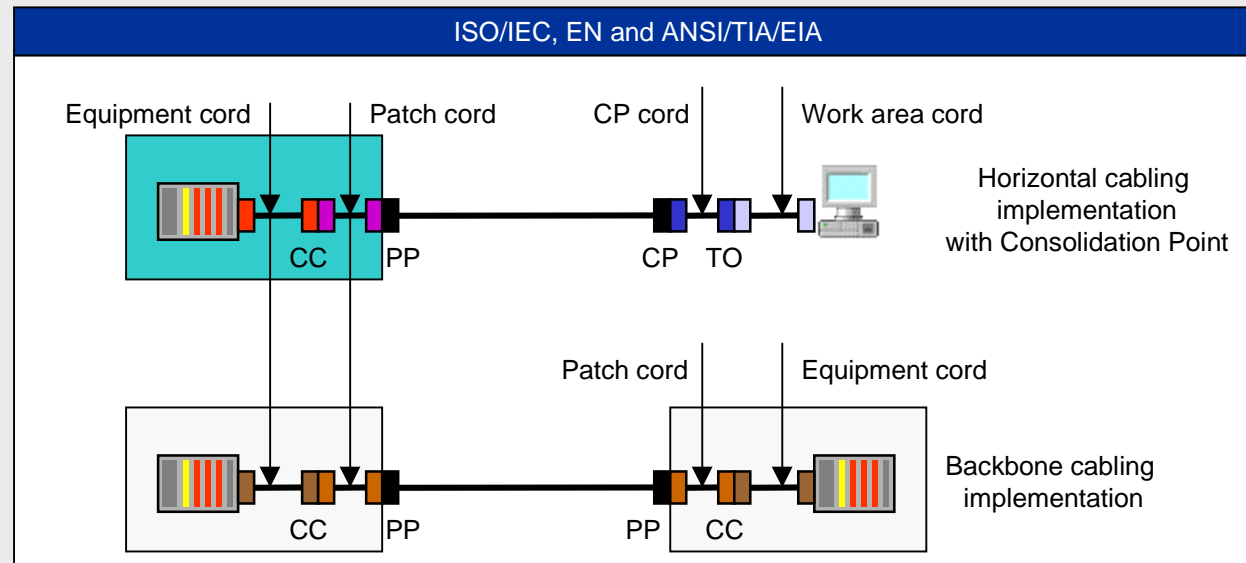

AGENDA

- Introduction
- The Standards
- The Requirements
- Recognising the Problem
- Break
- The Problem Areas
- Quality Planning
- Question Time
- Lunch
- A Universal Quality Plan
- Break
- Inspection
- Test Methodology
- Management of Failure
- Question Time
- Close

Conformant Links

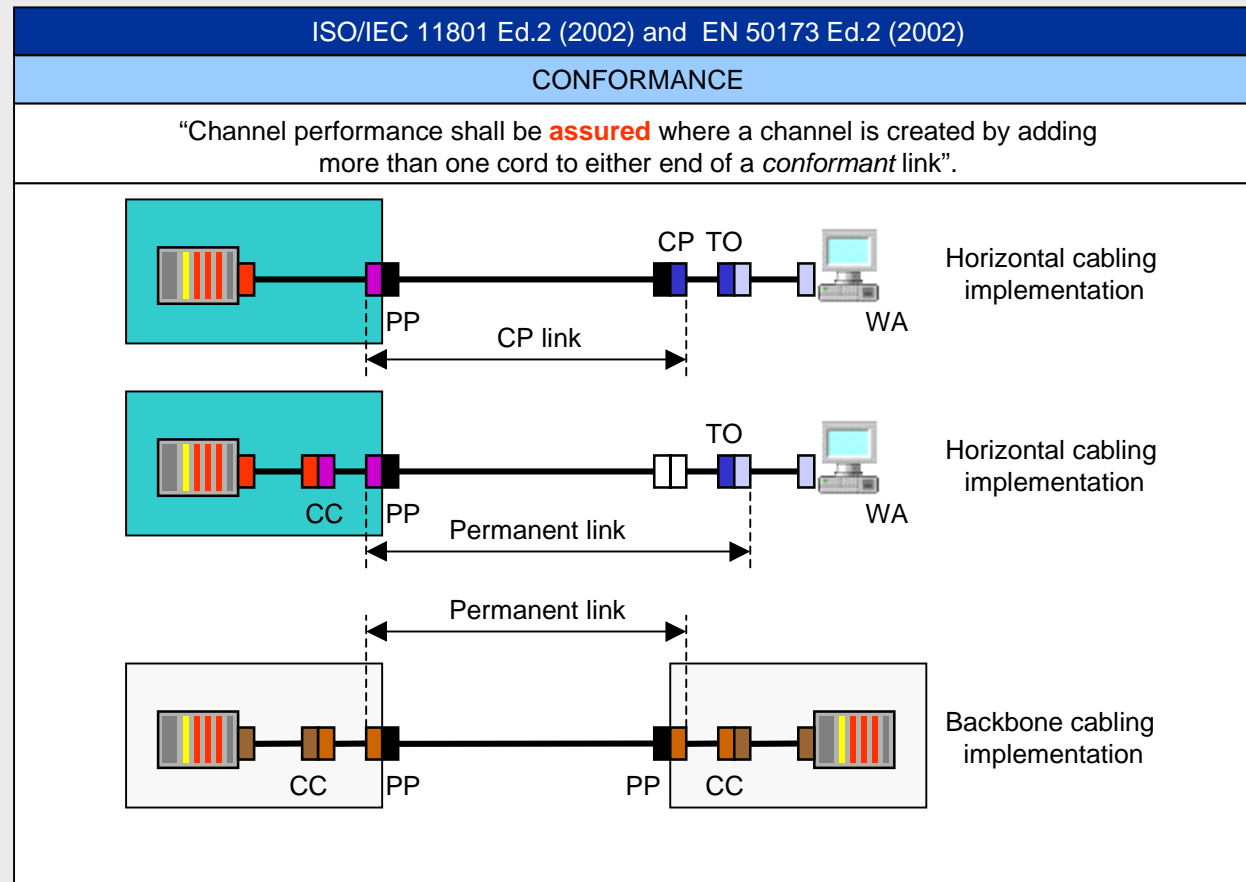

AGENDA

- Introduction
- The Standards
- The Requirements
- Recognising the Problem
- Break
- The Problem Areas
- Quality Planning
- Question Time
- Lunch
- A Universal Quality Plan
- Break
- Inspection
- Test Methodology
- Management of Failure
- Question Time
- Close

Reference Implementation

ISO/IEC and EN

$F = F_1 + F_2$

$X = \text{cord attenuation premium}$

$Y = \text{CP cable attenuation premium (if any)}$

No. of connections	Class D/Category 5	Class E/Category 6	Class F/Category 7
2	$H = (109-FX)/T$	$H = (107-3^1-FX)/T$	$H = (107-2^1-FX)/T$
3 w/o. CP	$H = (107-FX)/T$	$H = (106-3^1-FX)/T$	$H = (106-3^1-FX)/T$
3 inc. CP	$H = (107-FX-CY)/T$	$H = (106-3^1-FX-CY)/T$	$H = (106-3^1-FX-CY)/T$
4	$H = (105-FX-CY)/T$	$H = (105-3^1-FX-CY)/T$	$H = (105-4^1-FX-CY)/T$
$T = 1 + (t-20) \times \alpha$ where $t = \text{maximum design temperature within link}$			
	for screened cables		for unscreened cables
X and Y	1.5 typically		1.2 typically
α	= 0.002 for $t > 20^\circ\text{C}$		= 0.004 for $20^\circ\text{C} < t < 40^\circ\text{C}$ = 0.006 for $40^\circ\text{C} < t < 60^\circ\text{C}$
Note 1: this length reduction is provides margin for insertion loss deviation.			

AGENDA

- Introduction
- The Standards
- The Requirements
- Recognising the Problem
- Break
- The Problem Areas
- Quality Planning
- Question Time
- Lunch
- A Universal Quality Plan
- Break
- Inspection
- Test Methodology
- Management of Failure
- Question Time
- Close

The Great Escape - Part 2

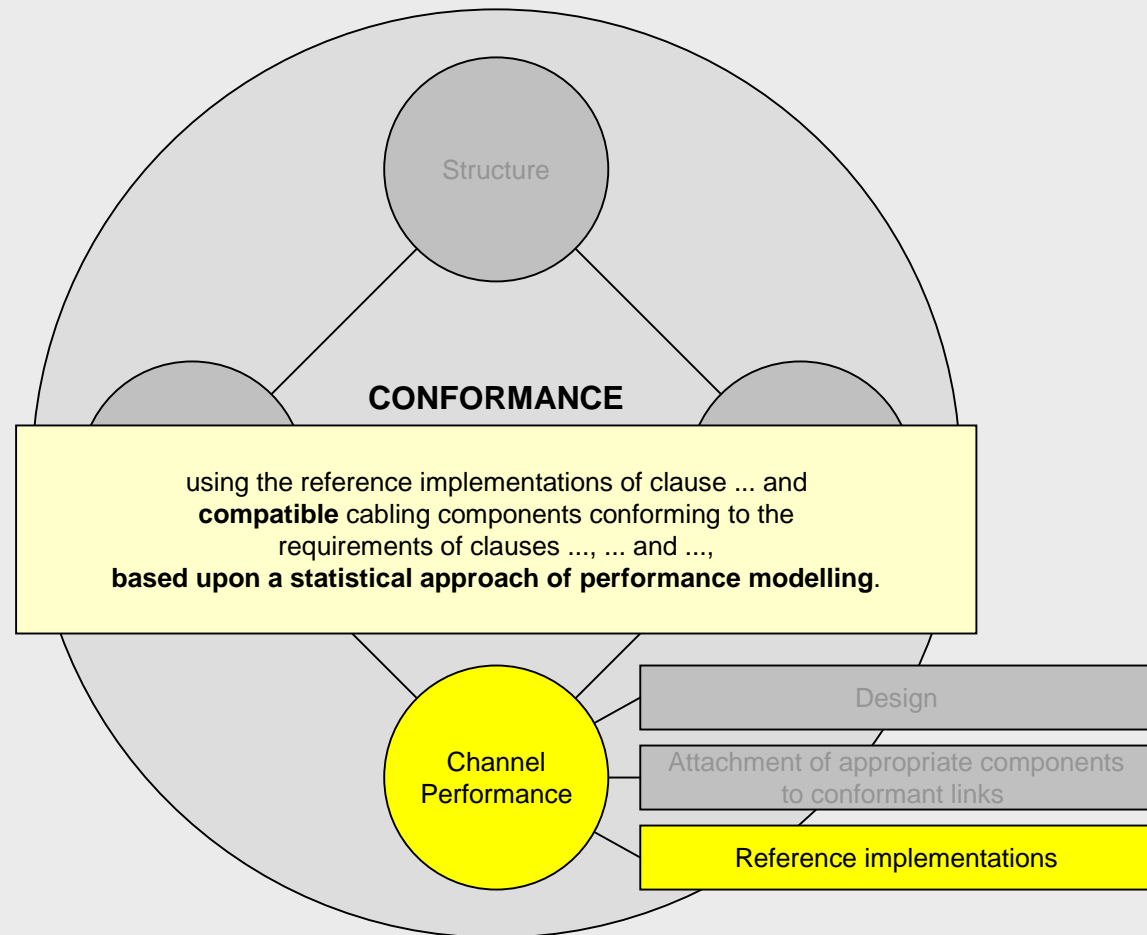

AGENDA

Introduction

The Standards

The Requirements

Recognising the Problem

Break

The Problem Areas

Quality Planning

Question Time

Lunch

A Universal Quality Plan

Break

Inspection

Test Methodology

Management of Failure

Question Time

Close

Break

AGENDA

Introduction

The Standards

The Requirements

Recognising the Problem

Break

The Problem Areas

Quality Planning

Question Time

Lunch

A Universal Quality Plan

Break

Inspection

Test Methodology

Management of Failure

Question Time

Close

The Problem Areas

In a Nutshell

Channel Creation

Channel and Link Test Limits

Copper

Optical Fibre

AGENDA

- Introduction
- The Standards
- The Requirements
- Recognising the Problem
- Break
- The Problem Areas
- Quality Planning
- Question Time
- Lunch
- A Universal Quality Plan
- Break
- Inspection
- Test Methodology
- Management of Failure
- Question Time
- Close

Channel Creation

ISO/IEC 11801 Ed.2 (2002), EN 50173 Ed.2 (2002) and ANSI/TIA/EIA-568-B.1

There are no restrictions on the length of:

- equipment and patch cords;
- CP cords/cables;
- work area cords.

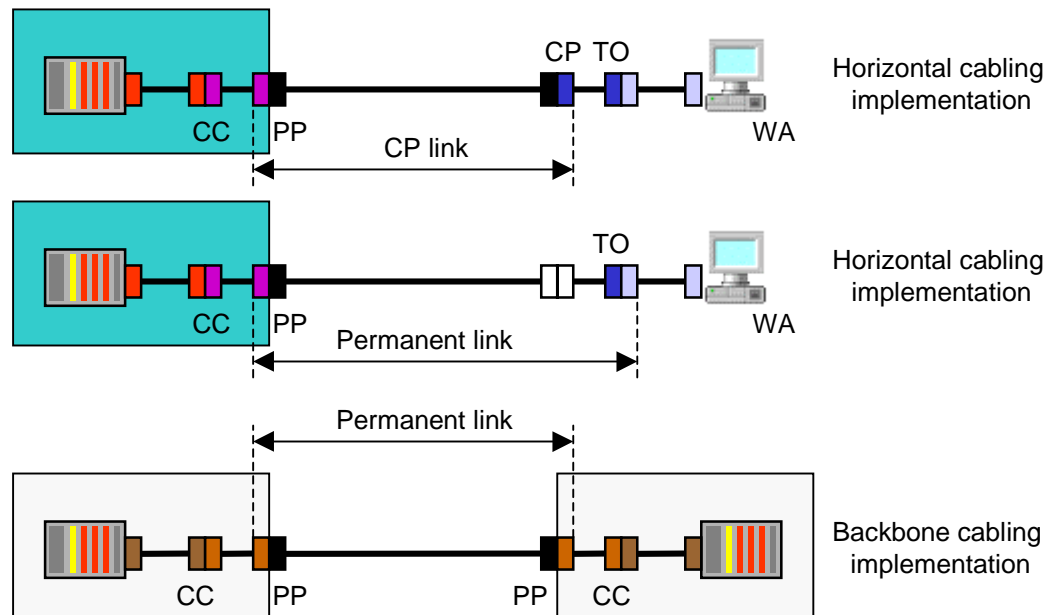

AGENDA

- Introduction
- The Standards
- The Requirements
- Recognising the Problem
- Break
- The Problem Areas
- Quality Planning
- Question Time
- Lunch
- A Universal Quality Plan
- Break
- Inspection
- Test Methodology
- Management of Failure
- Question Time
- Close

Channel and Link Test Limits

	ISO/IEC and EN	ANSI/TIA/EIA-568-B
Channel	Design independent Fixed limit	Design independent Fixed limit
Permanent Link	Design dependent Fixed maximum implementation limit	Design independent Fixed limit
CP Link	Design dependent Fixed maximum implementation limit	No specified limits

Complex requirement
-
Difficult to verify

Simple requirement
-
Inadequate QA

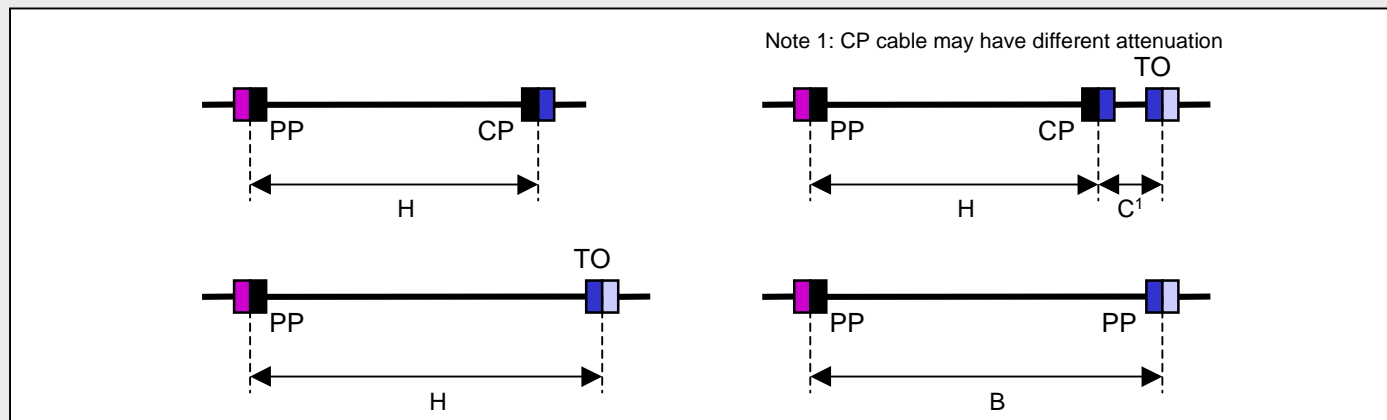

AGENDA

Introduction

The Standards

The Requirements

Recognising the Problem

Break

The Problem Areas

Quality Planning

Question Time

Lunch

A Universal Quality Plan

Break

Inspection

Test Methodology

Management of Failure

Question Time

Close

The Problem Areas: Copper

Length-related Parameters

Test Equipment Limitations

Channel Pre-Design

2 Connection Links

RL/NEXT Exclusions

3 Connection Links

The Channel Gap

Channels

Multi-Segment Cabling

Marginal/Fail Results

AGENDA

- Introduction
- The Standards
- The Requirements
- Recognising the Problem
- Break
- The Problem Areas
- Quality Planning
- Question Time
- Lunch
- A Universal Quality Plan
- Break
- Inspection
- Test Methodology
- Management of Failure
- Question Time
- Close

Length-related Parameters

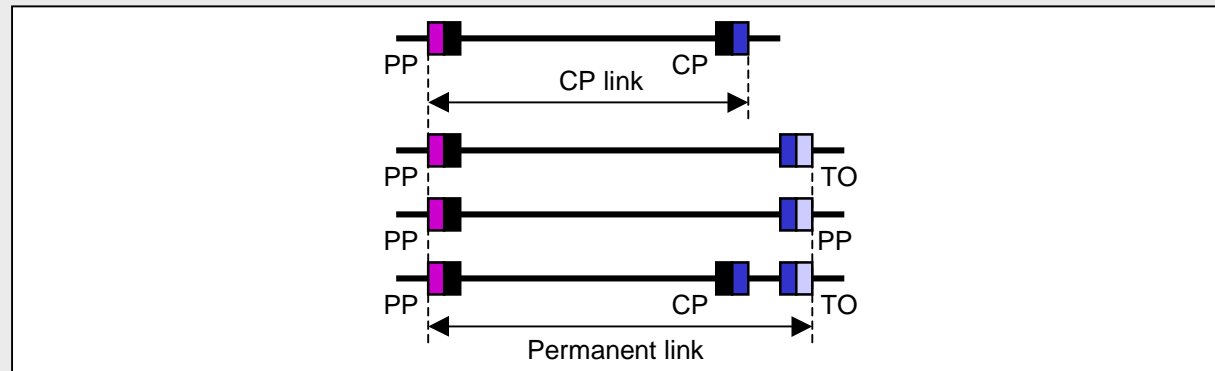

Class	Frequency	Maximum link insertion loss (dB)
D	$1 \leq f \leq 100$	$(L/100) * (1,9108 * \sqrt{f} + 0,0222 * f + 0,2 / \sqrt{f}) + n * 0,04 * \sqrt{f}$, 4dB min.
E	$1 \leq f \leq 250$	$(L/100) * (1,82 * \sqrt{f} + 0,0169 * f + 0,25 / \sqrt{f}) + n * 0,02 * \sqrt{f}$, 4dB min.
F	$1 \leq f \leq 600$	$(L/100) * (1,80 * \sqrt{f} + 0,010 * f + 0,2 / \sqrt{f}) + n * 0,02 * \sqrt{f}$, 4dB min.

Class	Frequency	Max. link loop resistance (Ω)
D E F	d.c	$(L/100) * 22 + n * 0,4$

n = number of connections within the link
 $L(m) = L_{FC} + L_{CP} * Y$ where
 L_{FC} = length of fixed cable and L_{CP} = length of CP cord,
 Y = attenuation premium for the CP cable/cord.

Class	Max. link propagation delay (μs)
D E F	$(L/100) * (0,534 + 0,036 / \sqrt{f}) + n * 0,0025$

Class	Max. link delay skew (μs)
D E F	$(L/100) * 0,025 + n * 0,00125$

n = number of connections within the link
 $L(m) = L_{FC} + L_{CP}$ where L_{FC} = length of fixed cable, L_{CP} = length of CP cord.

AGENDA

- Introduction
- The Standards
- The Requirements
- Recognising the Problem
- Break
- The Problem Areas
- Quality Planning
- Question Time
- Lunch
- A Universal Quality Plan
- Break
- Inspection
- Test Methodology
- Management of Failure
- Question Time
- Close

Test Equipment Limitations

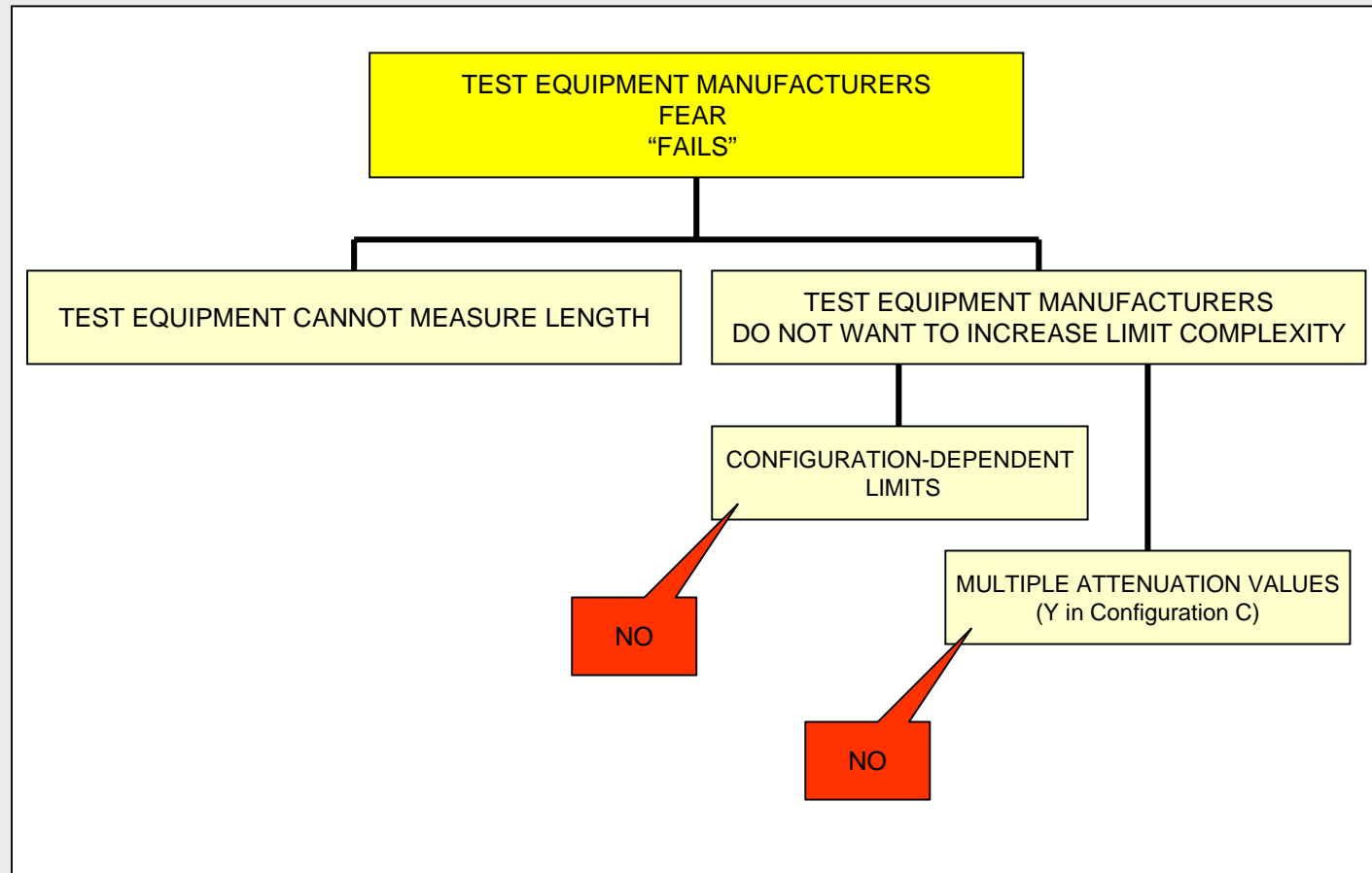

AGENDA

- Introduction
- The Standards
- The Requirements
- Recognising the Problem
- Break
- The Problem Areas
- Quality Planning
- Question Time
- Lunch
- A Universal Quality Plan
- Break
- Inspection
- Test Methodology
- Management of Failure
- Question Time
- Close

Attenuation and Delay Skew

ATTENUATION/INSERTION LOSS

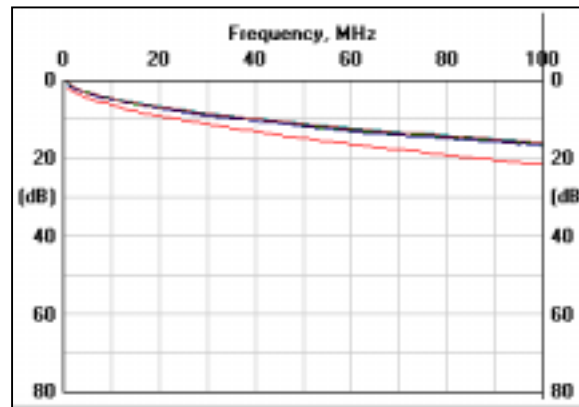

The highest measured attenuation/insertion loss occurs at the highest measurement frequency.

The test equipment will have to report the margin between the measured value and the channel limit at:

- 100 MHz for Class D compliance;
- 250 MHz for Class E compliance.

The installer has to check that the margin is acceptable.

	Class D	Class E
Connection	0,2 dB	0,32 dB
Solid cable	0,21 dB/m	0,33 dB/m
Stranded cable		
Unscreened cable	0,25 dB/m	0,40 dB/m
Screened cable	0,32 dB/m	0,50 dB/m

DELAY SKEW

Delay skew is constant with frequency

The installer has to check that the margin is acceptable.

	Class D	Class E
Connection	1,25 ns	
Cable	0,45 ns/m	

AGENDA

- Introduction
- The Standards
- The Requirements
- Recognising the Problem
- Break
- The Problem Areas
- Quality Planning
- Question Time
- Lunch
- A Universal Quality Plan
- Break
- Inspection
- Test Methodology
- Management of Failure
- Question Time
- Close

2 Connection Links

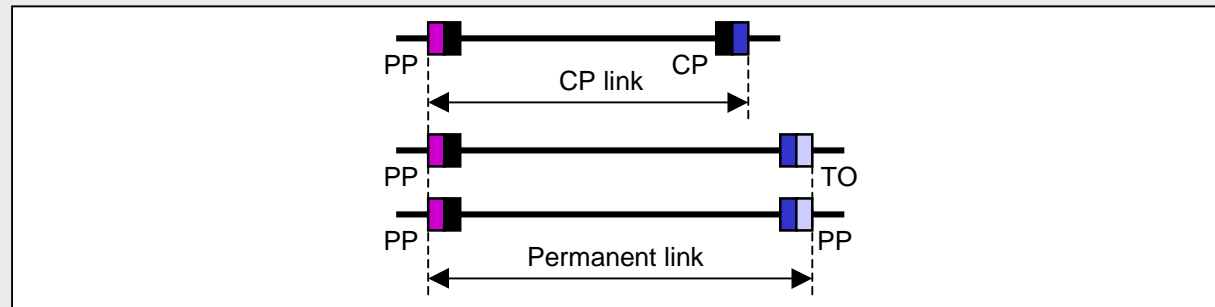

Class	Frequency	Minimum link return loss (dB)
C	$1 \leq f \leq 16$	Return loss requirements at frequencies at which the attenuation/insertion loss is below 3,0 dB are informative only
D	$1 \leq f \leq 100$	
E	$1 \leq f < 250$	
F	$1 \leq f < 600$	

Class	Frequency	Minimum link NEXT (dB)
A	$f = 0.1$	NEXT requirements at frequencies at which the attenuation/insertion loss is below 4,0 dB are informative only (ACR is mandatory)
B	$f \leq 1$	
C	$1 \leq f \leq 16$	
D	$1 \leq f \leq 100$	
E	$1 \leq f \leq 250$	
F	$1 \leq f \leq 600$	

Class	Frequency	Minimum link PSNEXT (dB)
D	$1 \leq f \leq 100$	See NEXT
E	$1 \leq f \leq 250$	
F	$1 \leq f \leq 600$	

AGENDA

Introduction

The Standards

The Requirements

Recognising the Problem

Break

The Problem Areas

Quality Planning

Question Time

Lunch

A Universal Quality Plan

Break

Inspection

Test Methodology

Management of Failure

Question Time

Close

RL Exclusion (2 Connections)

Approximate conditions for Class D, E and F

- lengths below 10m @ 100MHz
- lengths below 20m @ 31.25MHz
- lengths below 30m @ 20MHz
- lengths below 40m @ 10MHz

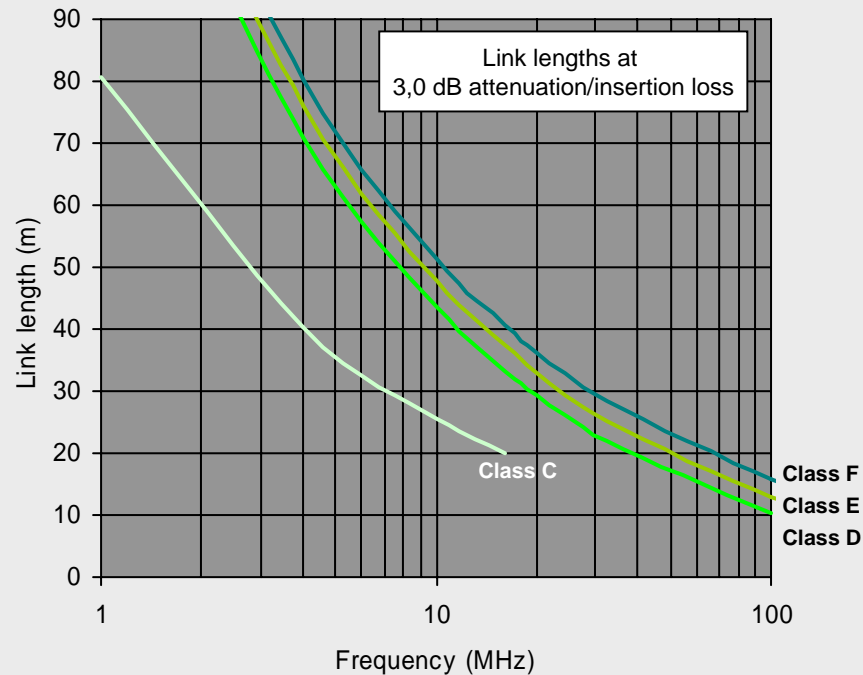

AGENDA

- Introduction
- The Standards
- The Requirements
- Recognising the Problem
- Break
- The Problem Areas
- Quality Planning
- Question Time
- Lunch
- A Universal Quality Plan
- Break
- Inspection
- Test Methodology
- Management of Failure
- Question Time
- Close

NEXT Exclusion (2 Connections)

- Approximate conditions for Class D, E and F
- lengths below 15m @ 100MHz
 - lengths below 30m @ 31.25MHz
 - lengths below 40m @ 20MHz
 - lengths below 60m @ 10MHz

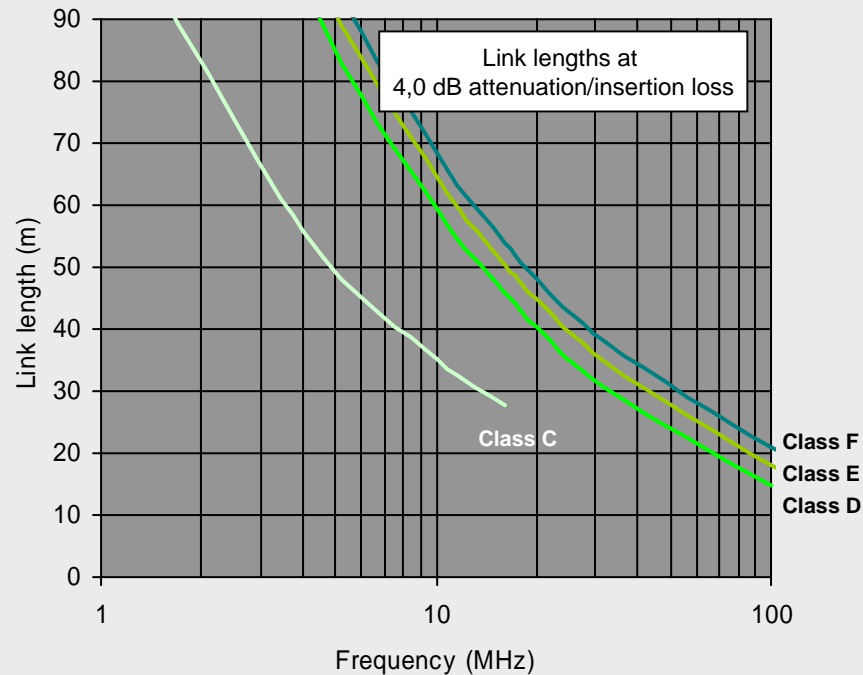

AGENDA

- Introduction
- The Standards
- The Requirements
- Recognising the Problem
- Break
- The Problem Areas
- Quality Planning
- Question Time
- Lunch
- A Universal Quality Plan
- Break
- Inspection
- Test Methodology
- Management of Failure
- Question Time
- Close

3 Connection Links

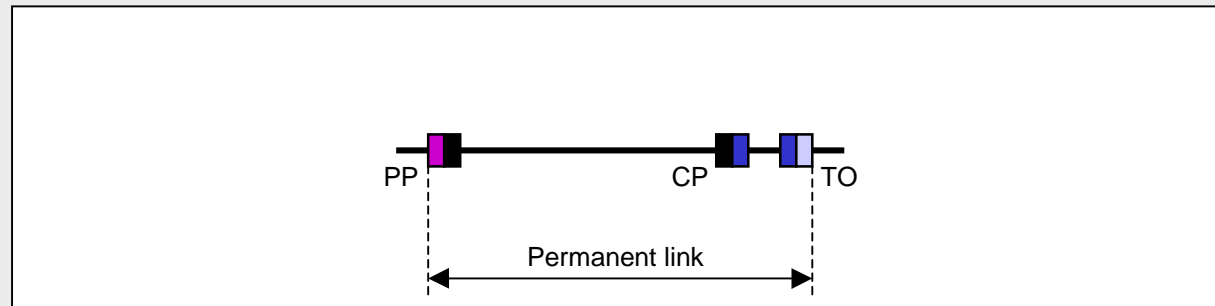

Class	Frequency	Minimum link return loss (dB)
C	$1 \leq f \leq 16$	Return loss for short lengths applies BUT risk of failure/marginal result due to CP cord/cable
D	$1 \leq f \leq 100$	
E	$1 \leq f < 250$	
F	$1 \leq f < 600$	

Class	Frequency	Minimum link NEXT (dB)
A	$f = 0.1$	NEXT for short lengths applies BUT risk of failure/marginal result due to CP cord/cable
B	$f \leq 1$	
C	$1 \leq f \leq 16$	
D	$1 \leq f \leq 100$	
E	$1 \leq f \leq 250$	
F	$1 \leq f \leq 600$	

Class	Frequency	Minimum link PSNEXT (dB)
D	$1 \leq f \leq 100$	See NEXT
E	$1 \leq f \leq 250$	
F	$1 \leq f \leq 600$	

AGENDA

- Introduction
- The Standards
- The Requirements
- Recognising the Problem
- Break
- The Problem Areas
- Quality Planning
- Question Time
- Lunch
- A Universal Quality Plan
- Break
- Inspection
- Test Methodology
- Management of Failure
- Question Time
- Close

The Channel Gap

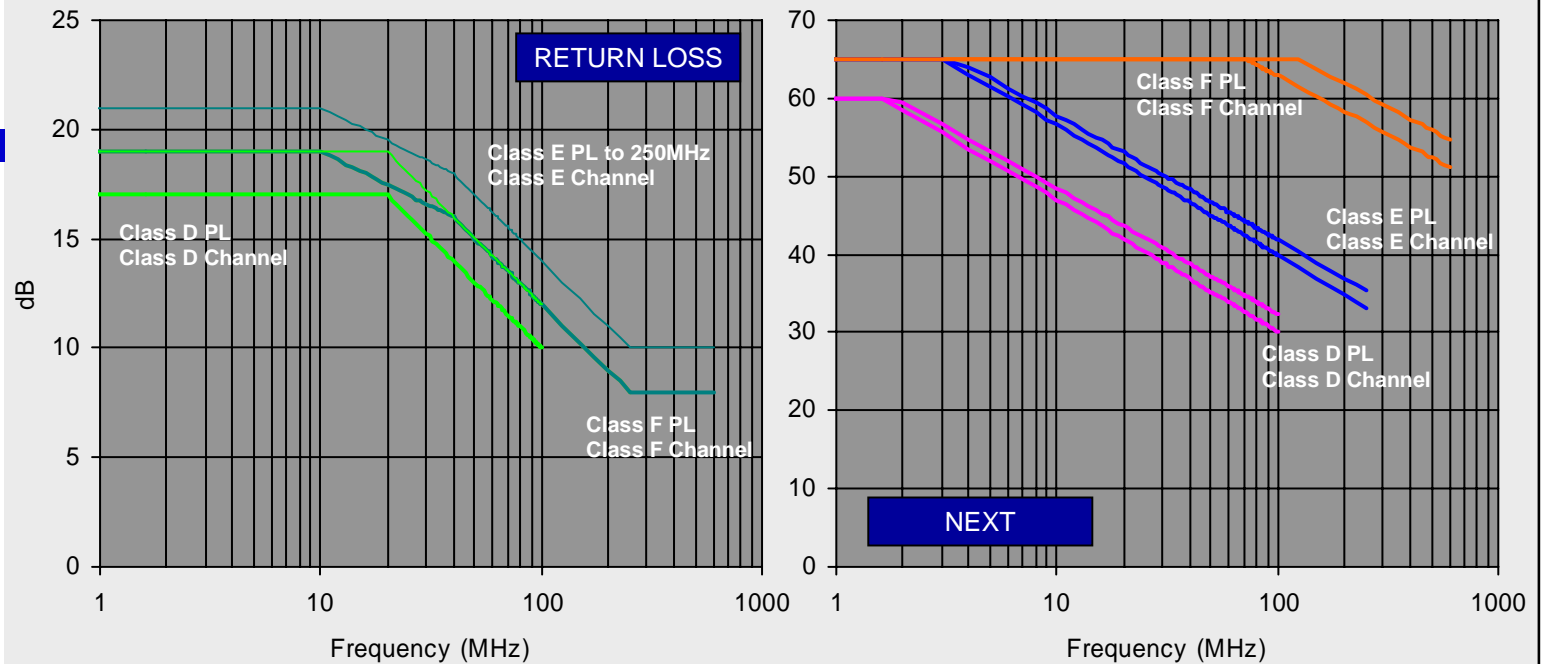

AGENDA

- Introduction
- The Standards
- The Requirements
- Recognising the Problem
- Break
- The Problem Areas
- Quality Planning
- Question Time
- Lunch
- A Universal Quality Plan
- Break
- Inspection
- Test Methodology
- Management of Failure
- Question Time
- Close

Channels

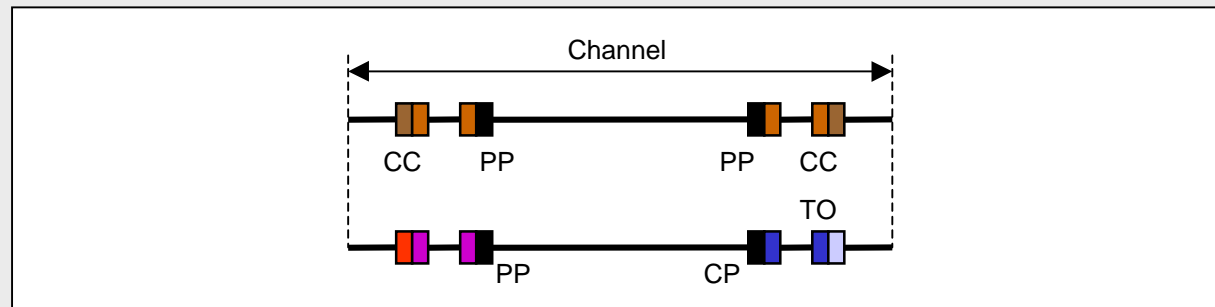

Class	Frequency	Minimum channel return loss (dB)
C	$1 \leq f \leq 16$	Return loss relaxation for short lengths applies BUT risk of failure/marginal result due to CP cord/cables, patch and equipment cords
D	$1 \leq f \leq 100$	
E	$1 \leq f < 250$	
F	$1 \leq f < 600$	

Class	Frequency	Minimum channel NEXT (dB)
A	$f = 0.1$	NEXT relaxation for short lengths applies BUT risk of failure/marginal result due to CP cord/cables, patch and equipment cords
B	$f \leq 1$	
C	$1 \leq f \leq 16$	
D	$1 \leq f \leq 100$	
E	$1 \leq f \leq 250$	
F	$1 \leq f \leq 600$	

Class	Frequency	Minimum channel PSNEXT (dB)
D	$1 \leq f \leq 100$	See NEXT
E	$1 \leq f \leq 250$	
F	$1 \leq f \leq 600$	

AGENDA

Introduction

The Standards

The Requirements

Recognising the Problem

Break

The Problem Areas

Quality Planning

Question Time

Lunch

A Universal Quality Plan

Break

Inspection

Test Methodology

Management of Failure

Question Time

Close

Multi-segment Cabling

Return loss reductions

- impedance mismatches between connection components
 - impedance mismatches between cables
 - “standing wave” (quarter wavelength) effects

Real risk of failure using compliant components

NEXT/PSNEXT reductions

- close proximity of multiple connections

Real risk of marginal results using compliant components

AGENDA

- Introduction
- The Standards
- The Requirements
- Recognising the Problem
- Break
- The Problem Areas
- Quality Planning
- Question Time
- Lunch
- A Universal Quality Plan
- Break
- Inspection
- Test Methodology
- Management of Failure
- Question Time
- Close

Marginal/Fail Results

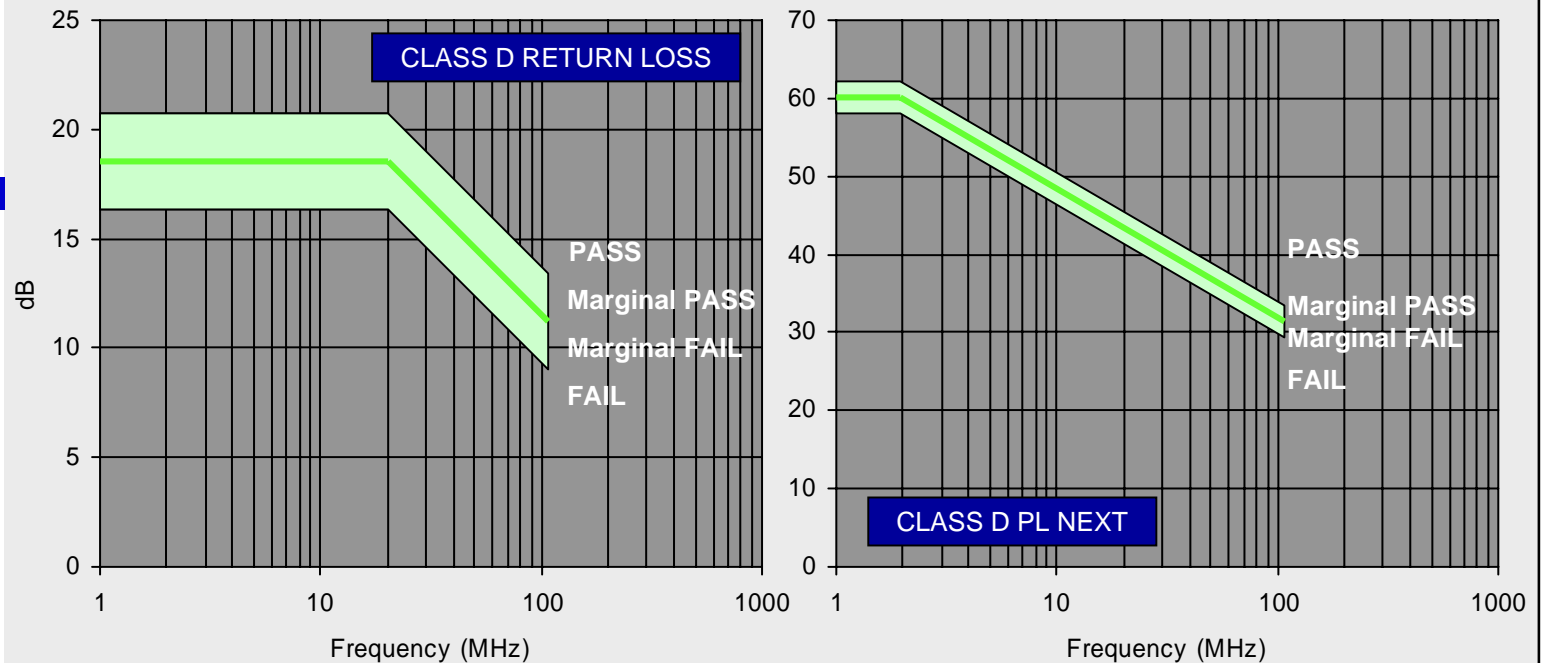

AGENDA

Introduction

The Standards

The Requirements

Recognising the Problem

Break

The Problem Areas

Quality Planning

Question Time

Lunch

A Universal Quality Plan

Break

Inspection

Test Methodology

Management of Failure

Question Time

Close

The Problem Areas: Optical Fibre

Channel and Link Requirements

Application Requirements

LSPM Measurement

Implications for Test Results

Typical Results

Pass/Fail Indicators

AGENDA

- Introduction
- The Standards
- The Requirements
- Recognising the Problem
- Break
- The Problem Areas
- Quality Planning
- Question Time
- Lunch
- A Universal Quality Plan
- Break
- Inspection
- Test Methodology
- Management of Failure
- Question Time
- Close

Channel and Link Requirements

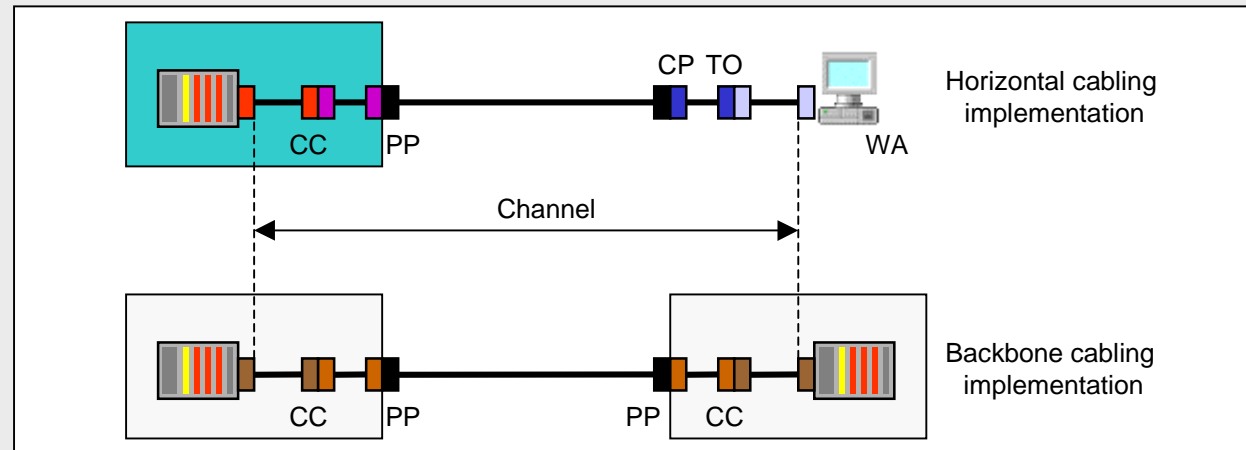

Channel requirements	Class	Maximum length (m)	Maximum attenuation (dB)			
			Multimode		Singlemode	
			850 nm	1300 nm	1310 nm	1550 nm
	OF-300	300	2,55	1,95	1,80	1,80
	OF-500	500	3,25	2,25	2,00	2,00
	OF-2000	2000	8,50	4,50	3,50	3,50

Link requirements	Multimode	λ	Maximum attenuation (dB)
		850nm	$0,0035 * L + 0.75 * n$
	1300nm	$0,0015 * L + 0.75 * n$	
	Singlemode	1310nm	$0,001 * L + 0.75 * n$
1550nm		$0,001 * L + 0.75 * n$	

n = number of connections within the link
L(m) = link length

AGENDA

Introduction

The Standards

The Requirements

Recognising the Problem

Break

The Problem Areas

Quality Planning

Question Time

Lunch

A Universal Quality Plan

Break

Inspection

Test Methodology

Management of Failure

Question Time

Close

Application Requirements

Application			Optical Fibre			
			50/125 (OM2)		62.5/125 (OM1)	
Mb/s	Network	λ	Max. length (m)	OPB/CIL max. (dB)	Max. length (m)	OPB/CIL max. (dB)
4	Token Ring	850 nm	1857 ¹	8.0	2000	13.0
10	Ethernet		1514 ¹	6.8	2000	12.5
16	Token Ring		1857 ¹	8.0	2000	13.0
100	Ethernet	1300 nm	2000	6.0	2000	11.0
1000	Ethernet	850 nm	550	3.56	275	2.6
1000	Ethernet	1300 nm	550	2.35	550	2.35
10000	Ethernet	850 nm	82	1.80	33	1.60
10000	Ethernet	CWDM/1300	300	1.96	300	1.96
			50/125 (OM3)			
10000	Ethernet	850 nm	300	2.59		

¹ Calculated values using 1.5dB of connecting hardware losses

AGENDA

- Introduction
- The Standards
- The Requirements
- Recognising the Problem
- Break
- The Problem Areas
- Quality Planning
- Question Time
- Lunch
- A Universal Quality Plan
- Break
- Inspection
- Test Methodology
- Management of Failure
- Question Time
- Close

LSPM Measurement

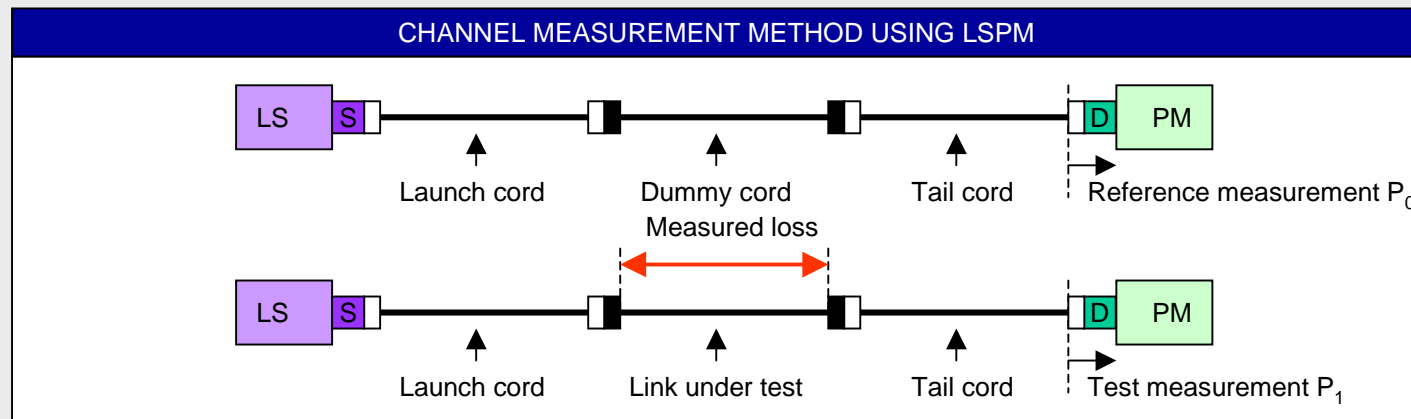
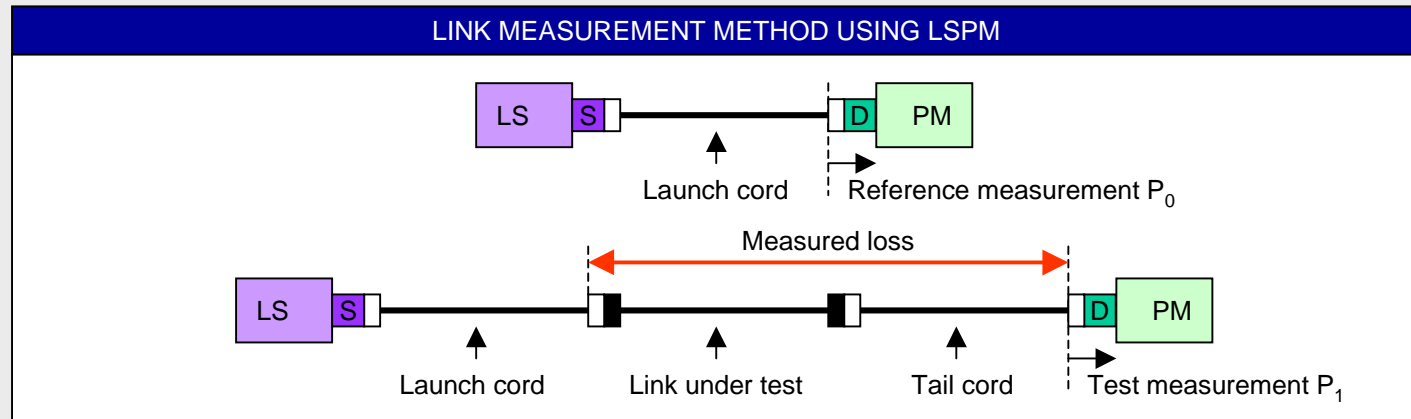

Measurement accuracy of LSPM systems ≈ 0.7 dB plus other mismatches

AGENDA

- Introduction
- The Standards
- The Requirements
- Recognising the Problem
- Break
- The Problem Areas
- Quality Planning
- Question Time
- Lunch
- A Universal Quality Plan
- Break
- Inspection
- Test Methodology
- Management of Failure
- Question Time
- Close

Implications for Test Results

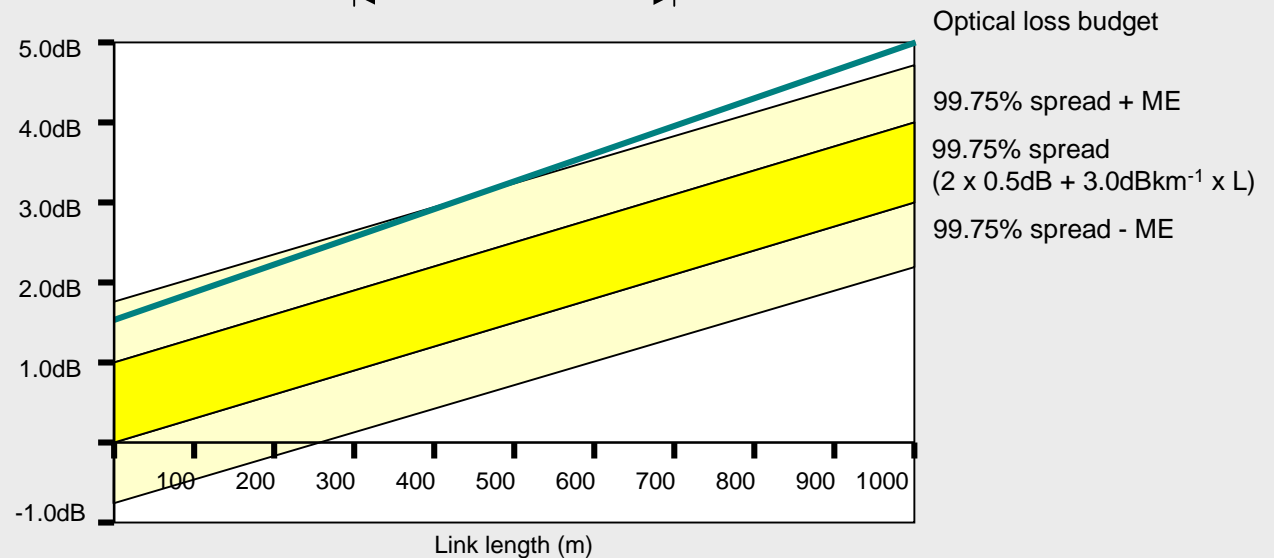
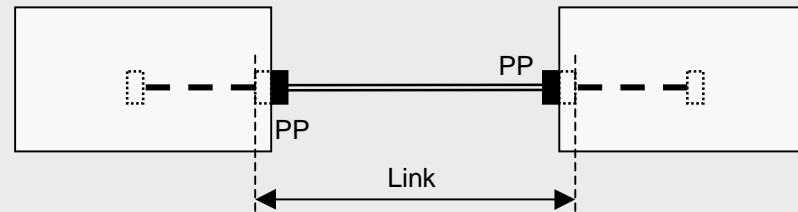

AGENDA

Introduction

The Standards

The Requirements

Recognising the Problem

Break

The Problem Areas

Quality Planning

Question Time

Lunch

A Universal Quality Plan

Break

Inspection

Test Methodology

Management of Failure

Question Time

Close

Typical Results

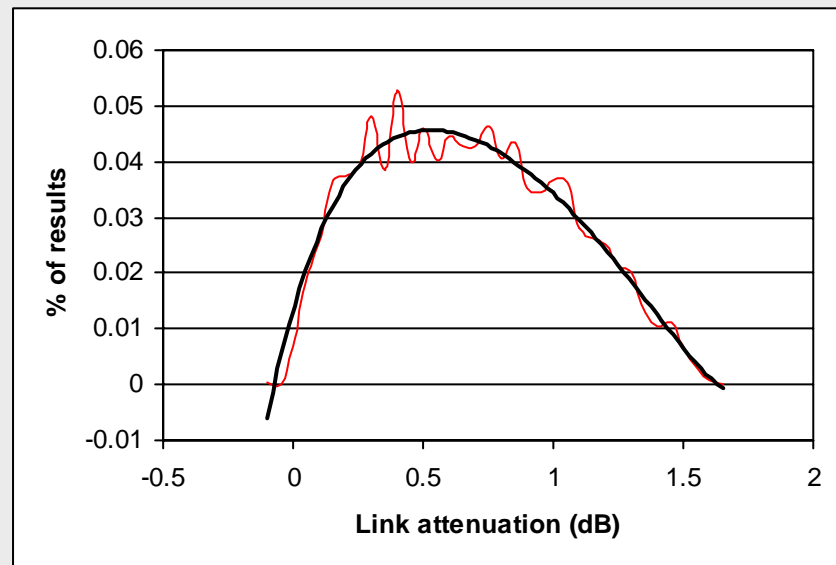

AGENDA

Introduction

The Standards

The Requirements

Recognising the Problem

Break

The Problem Areas

Quality Planning

Question Time

Lunch

A Universal Quality Plan

Break

Inspection

Test Methodology

Management of Failure

Question Time

Close

Pass/Fail Indicators

Test equipment that
not only
measures
but also
ADJUDICATES

Application support based upon:

- length (requiring the modal bandwidth of the optical fibre to be input);
- measured link/channel loss.

Cabling performance against calculation of optical loss budget based upon:

- number and type of joints
- length;
- measured link/channel loss.

**PASS/FAIL INDICATORS ARE VERY SUSCEPTIBLE
TO SHORT LENGTH SYNDROME
(measurement error)**

AGENDA

Introduction

The Standards

The Requirements

Recognising the Problem

Break

The Problem Areas

Quality Planning

The Impact of Standardisation

Question Time

The Protection Plan

Lunch

A Universal Quality Plan

Break

Inspection

Test Methodology

Management of Failure

Question Time

Close

Quality Planning

AGENDA

Introduction

The Standards

The Requirements

Recognising the Problem

Break

The Problem Areas

Quality Planning

Question Time

Lunch

A Universal Quality Plan

Break

Inspection

Test Methodology

Management of Failure

Question Time

Close

The Impact of Standardisation

Standardisation promotes commoditisation

Commoditisation produces nominally compliant products

Nominally compliant products produce marginal/failing results
(in certain circumstances)

AGENDA

- Introduction
- The Standards
- The Requirements
- Recognising the Problem
- Break
- The Problem Areas
- Quality Planning
- Question Time
- Lunch
- A Universal Quality Plan
- Break
- Inspection
- Test Methodology
- Management of Failure
- Question Time
- Close

The Protection Plan

ISO/IEC 11801 Ed.2 (2002) and EN 50173 Ed.2 (2002)

CONFORMANCE

“
The performance of ... channels shall meet the requirements specified in clause
This shall be achieved by one of the following:
i) ...
ii) ...
iii) using the reference implementations of clause ... and *compatible* cabling components conforming to the requirements of clauses ..., ... and ..., *based upon a statistical approach of performance modelling*.
”

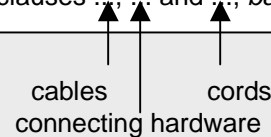

ISO/IEC 11801 Ed.2 (2002) and EN 50173 Ed.2 (2002)

CONFORMANCE

“Channel performance shall be explicitly verified where a channel is created by adding more than one cord to either end of a *conformant* link”.

ISO/IEC 11801 Ed.2 (2002) and EN 50173 Ed.2 (2002)

CONFORMANCE

The treatment of measured results that fail to meet the requirements or lie within the relevant measurement accuracy, shall be clearly documented within a quality plan as described in ...

AGENDA

Introduction

The Standards

The Requirements

Recognising the Problem

Break

The Problem Areas

Quality Planning

Question Time

Lunch

A Universal Quality Plan

Break

Inspection

Test Methodology

Management of Failure

Question Time

Close

Question Time

AGENDA

Introduction

The Standards

The Requirements

Recognising the Problem

Break

The Problem Areas

Quality Planning

Question Time

Lunch

A Universal Quality Plan

Break

Inspection

Test Methodology

Management of Failure

Question Time

Close

Lunch

AGENDA

A Universal Quality Plan

Introduction

The Standards

The Requirements

Recognising the Problem

Break

The Problem Areas

Quality Planning

Question Time

Lunch

A Universal Quality Plan

Break

Inspection

Test Methodology

Management of Failure

Question Time

Close

Installation QA

The Quality Plan: EN 50174-1

Inspection Criteria

Testing with Assurance

Identify the Margins

Cord Performance

Copper Test Methods

OF Test Methods

OF LSPM Test Methods

LSPM Equipment Grades (FIA)

OF OTDR Test Methods

OF Test Method Glossary

The Importance of Test Cords

Copper Test Configuration

OF LSPM Test Configuration

OF OTDR Test Configuration

Administration of Test Cords

OF Test Cord Launch Conditions

MMF Launch Cord Mandrel Wrap

Administration of Test Results

Management of Test Results

Delivery of Test Results

AGENDA

- Introduction
- The Standards
- The Requirements
- Recognising the Problem
- Break
- The Problem Areas
- Quality Planning
- Question Time
- Lunch
- A Universal Quality Plan
- Break
- Inspection
- Test Methodology
- Management of Failure
- Question Time
- Close

Installation QA

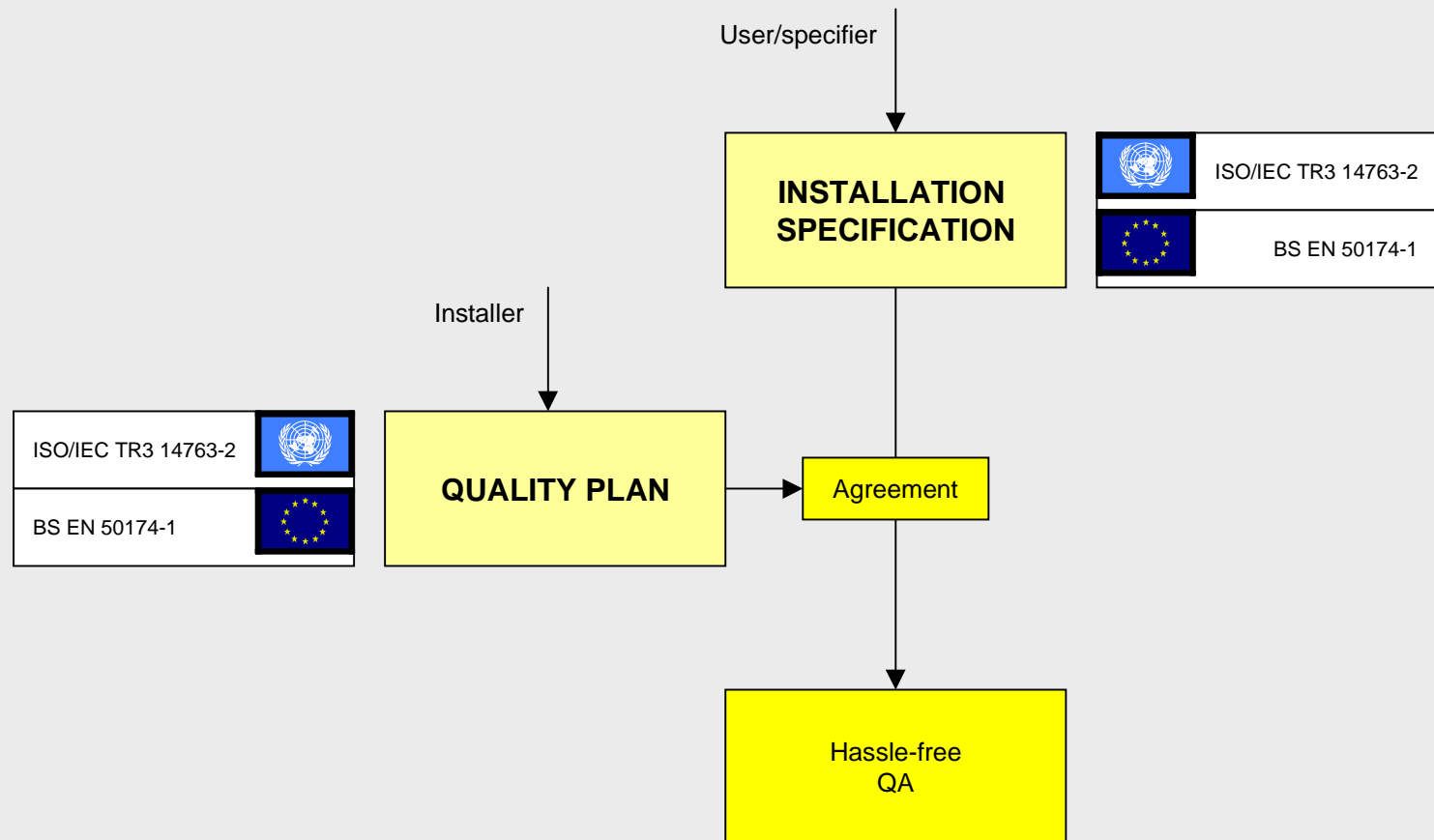

AGENDA

Introduction
The Standards
The Requirements
Recognising the Problem
Break
The Problem Areas
Quality Planning
Question Time
Lunch
A Universal Quality Plan
Break
Inspection
Test Methodology
Management of Failure
Question Time
Close

The Quality Plan: EN 50174-1

CONTRACT
Interfaces
Transfer of responsibility

COMPETENCE
Training plans
Training records
Qualifications
Evidenciary requirements

COMPONENT ACCEPTANCE	LEGACY CABLING
Inspection and test regimes	
Sampling plans	
Test equipment, calibration	

INSTALLATION
Inspection routines

INSTALLED CABLING ACCEPTANCE
Inspection and test regimes
Sampling plans
Test equipment
Calibration and storage
Fault resolution

AGENDA

Introduction

The Standards

The Requirements

Recognising the Problem

Break

The Problem Areas

Quality Planning

Question Time

Lunch

A Universal Quality Plan

Break

Inspection

Test Methodology

Management of Failure

Question Time

Close

Inspection Criteria

TESTING IS NOT A SUBSTITUTE FOR EFFECTIVE INSPECTION

AGENDA

Introduction

The Standards

The Requirements

Recognising the Problem

Break

The Problem Areas

Quality Planning

Question Time

Lunch

A Universal Quality Plan

Break

Inspection

Test Methodology

Management of Failure

Question Time

Close

Testing with Assurance

READ THE INSTALLATION SPECIFICATION

KNOW YOUR LIMITS

- which standard?
- which issue?

UNDERSTAND THE MARGINS

- undertake a channel design review
- make sure the client understands it

CLARIFY THE TEST METHODS

- which standard?
- which issue?

ADMINISTER THE TEST RESULTS

- test configuration
- test identifier

PLAN FOR FAILURE

- can "FAIL"s be expected?
- under which conditions?
 - what happens next?
- agree process with client

TEST CORDS - TEST CORDS
TEST CORDS - TEST CORDS

AGENDA

- Introduction
- The Standards
- The Requirements
- Recognising the Problem
- Break
- The Problem Areas
- Quality Planning
- Question Time
- Lunch
- A Universal Quality Plan
- Break
- Inspection
- Test Methodology
- Management of Failure
- Question Time
- Close

Identify the Margins

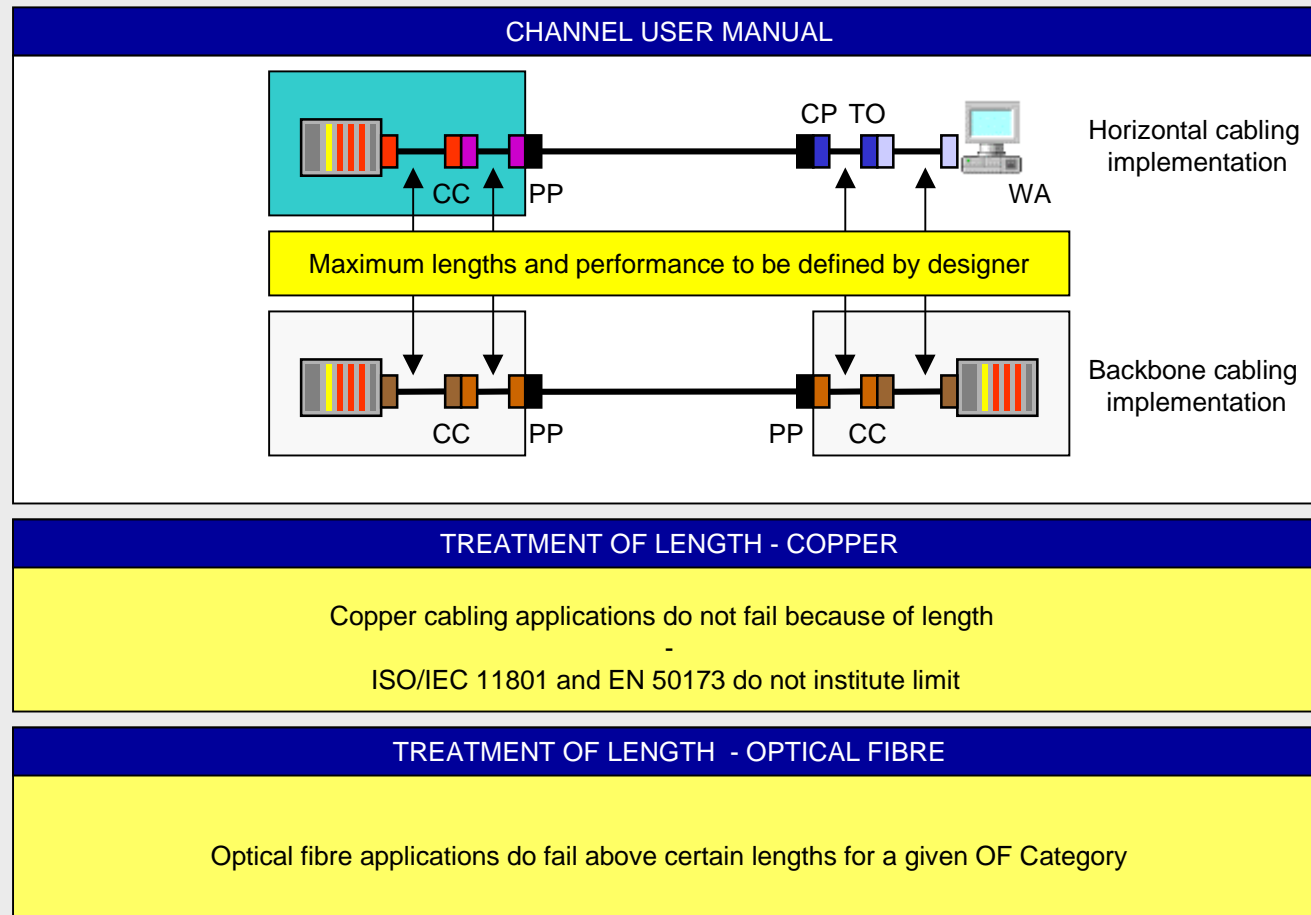

AGENDA

Introduction

The Standards

The Requirements

Recognising the Problem

Break

The Problem Areas

Quality Planning

Question Time

Lunch

A Universal Quality Plan

Break

Inspection

Test Methodology

Management of Failure

Question Time

Close

Cord Performance

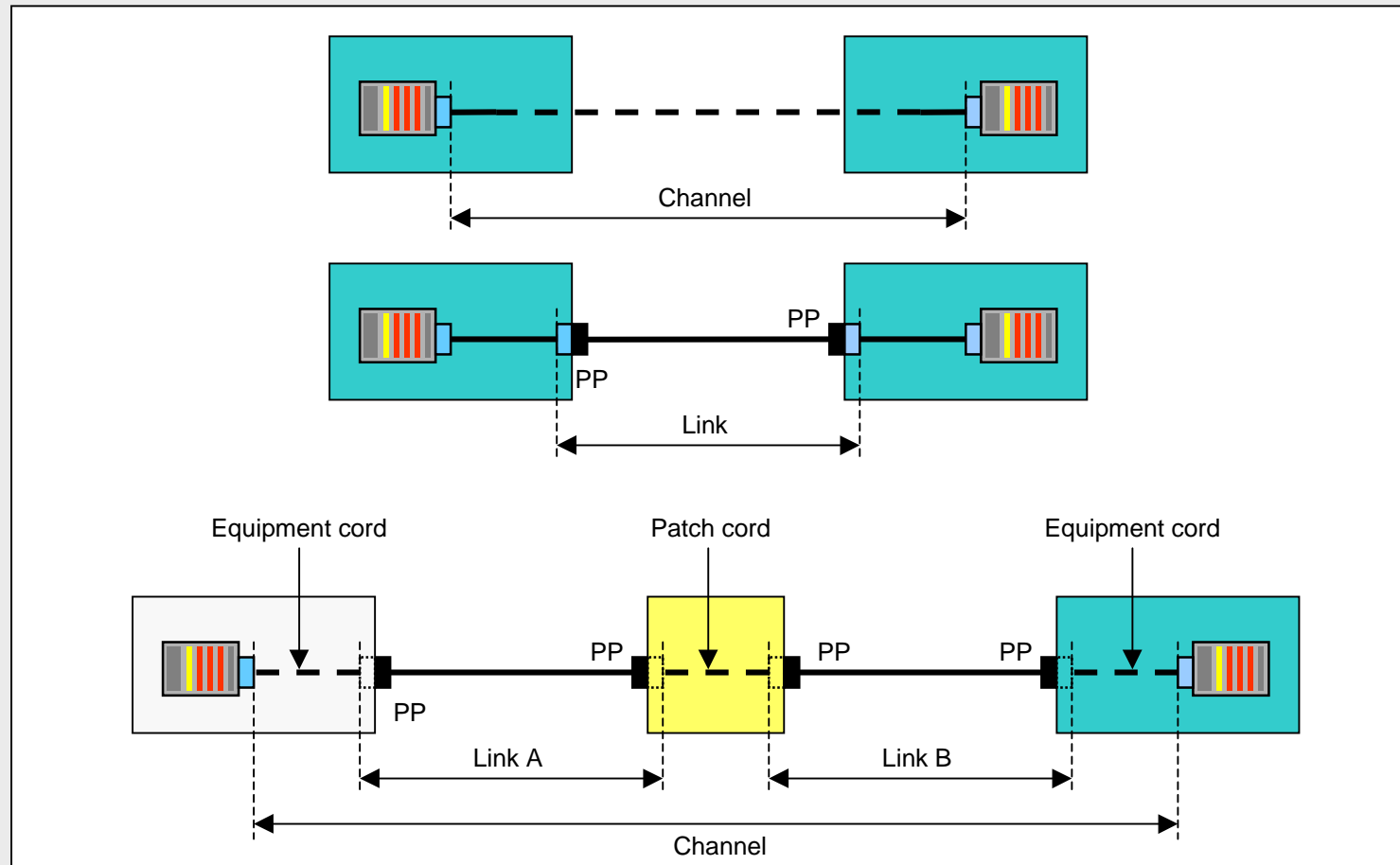

AGENDA

- Introduction
- The Standards
- The Requirements
- Recognising the Problem
- Break
- The Problem Areas
- Quality Planning
- Question Time
- Lunch
- A Universal Quality Plan
- Break
- Inspection
- Test Methodology
- Management of Failure
- Question Time
- Close

Copper Test Methods

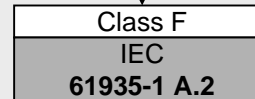
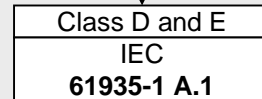
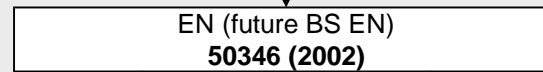
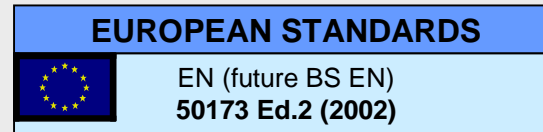
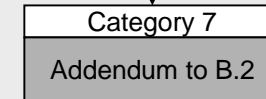
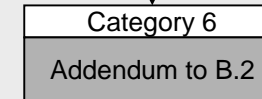
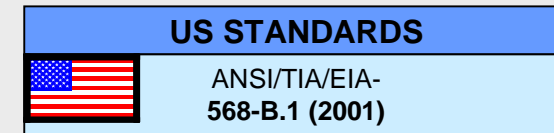
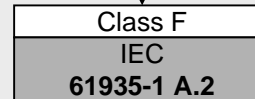
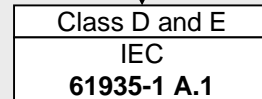
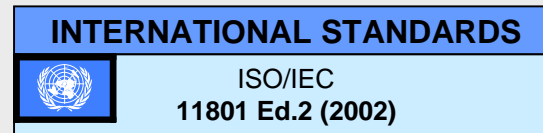

AGENDA

Introduction
The Standards
The Requirements
Recognising the Problem
Break
The Problem Areas
Quality Planning
Question Time
Lunch
A Universal Quality Plan
Break
Inspection
Test Methodology
Management of Failure
Question Time
Close

OF Test Methods

TEST REGIME	ITEMS UNDER TEST	TESTING APPROACH	TEST TOOL
Component Acceptance	Cables	Component loss	OTDR
	Cords	Overall loss	LSPM
		Component loss	LSPM
Legacy Cabling Acceptance	Links and channels	Overall loss	LSPM
		Component loss	OTDR
Partial Completion Tests	Links	Component loss	OTDR
Installed Cabling Acceptance	Links and channels	Overall loss	LSPM
		Component loss	OTDR
Fault Diagnosis	Links and channels	Component loss	OTDR

AGENDA

- Introduction
- The Standards
- The Requirements
- Recognising the Problem
- Break
- The Problem Areas
- Quality Planning
- Question Time
- Lunch
- A Universal Quality Plan
- Break
- Inspection
- Test Methodology
- Management of Failure
- Question Time
- Close

OF LSPM Test Methods

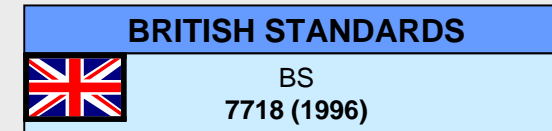
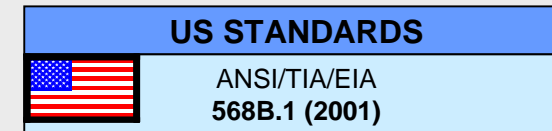
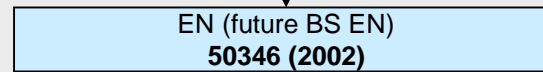
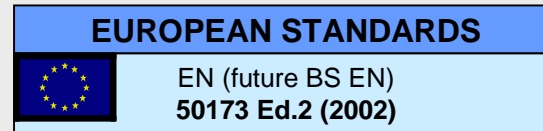
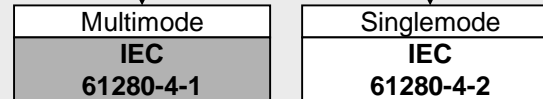
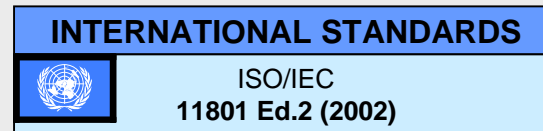

BI-DIRECTIONAL OF TESTING

This may be a specific customer requirement but there is no need for bi-directional testing providing that the correct methods and cords are used

TESTING WAVELENGTH

The Installation Specification defines the wavelength(s). ISO/IEC 11801 and EN 50173 require dual λ testing. Application support requires specific λ test.

AGENDA

- Introduction
- The Standards
- The Requirements
- Recognising the Problem
- Break
- The Problem Areas
- Quality Planning
- Question Time
- Lunch
- A Universal Quality Plan
- Break
- Inspection
- Test Methodology
- Management of Failure
- Question Time
- Close

LSPM Equipment Grades (FIA)

<p>Grade 1</p> <ul style="list-style-type: none"> • simplex • single wavelength 		Component- based
<p>Grade 2</p> <ul style="list-style-type: none"> • simplex • dual wavelength 		Component- based
<p>Grade 3</p> <ul style="list-style-type: none"> • simplex • auto dual wavelength 		System-based
<p>Grade 4</p> <ul style="list-style-type: none"> • duplex • dual wavelength 		System-based
<p>Grade 5</p> <ul style="list-style-type: none"> • duplex • auto dual wavelength 		System-based

Includes single location Grade 3

AGENDA

- Introduction
- The Standards
- The Requirements
- Recognising the Problem
- Break
- The Problem Areas
- Quality Planning
- Question Time
- Lunch
- A Universal Quality Plan
- Break
- Inspection
- Test Methodology
- Management of Failure
- Question Time
- Close

OF OTDR Test Methods

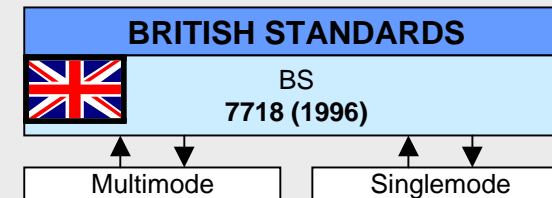
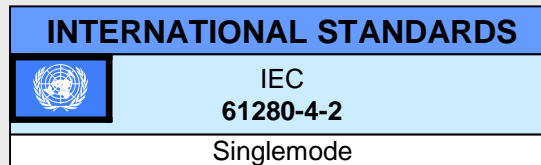

AGENDA

Introduction

The Standards

The Requirements

Recognising the Problem

Break

The Problem Areas

Quality Planning

Question Time

Lunch

A Universal Quality Plan

Break

Inspection

Test Methodology

Management of Failure

Question Time

Close

OF Test Method Glossary

ARENA	REFERENCE	TITLE
IEC	61280-4-1	Fibre optic communication subsystem basic test procedures - Part 4-1: Fibre optic cable plant - Multimode fibre optic cable plant attenuation
IEC	61280-4-2	Fibre optic communication subsystem basic test procedures - Part 4-2: Fibre optic cable plant - Single-mode fibre optic cable plant attenuation
EN	50346	Information Technology - Testing of installed cabling
TIA/EIA	526-14-A	OFSTP-14A Optical Power Loss Measurement of Installed Multimode Fiber Cable Plant (ANSI/TIA/EIA-526-14A-98)
TIA/EIA	526-7	OFSTP-7 Measurement of Optical Power Loss of Installed Single-Mode Fiber Cable Plant (ANSI/TIA/EIA-526-7-98)
UK FIA	TSD-2000-4-2-1	Testing of installed cabling using LSPM equipment
UK FIA	TSD-2000-4-2-2	Testing of installed cabling using OTDR equipment

AGENDA

Introduction

The Standards

The Requirements

Recognising the Problem

Break

The Problem Areas

Quality Planning

Question Time

Lunch

A Universal Quality Plan

Break

Inspection

Test Methodology

Management of Failure

Question Time

Close

Copper Test Configuration

PERMANENT LINK MEASUREMENT CONFIGURATION

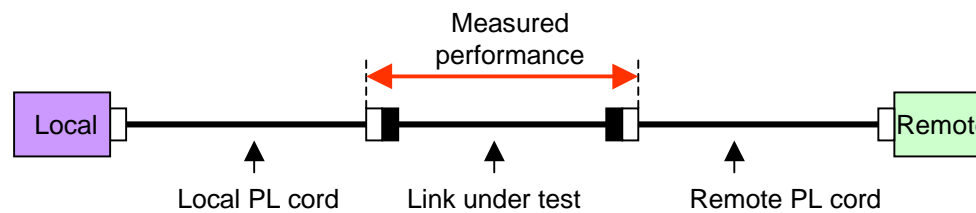

CHANNEL MEASUREMENT CONFIGURATION

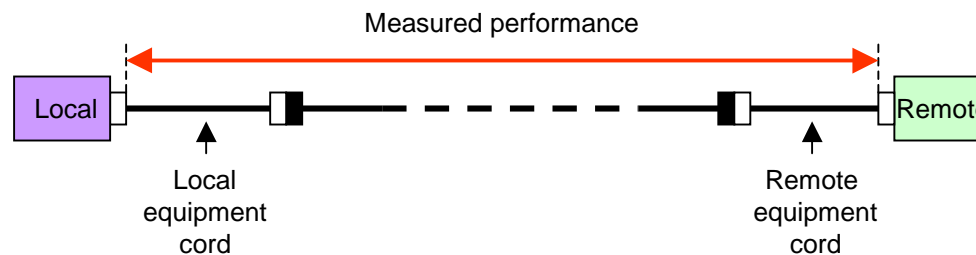

AGENDA

- Introduction
- The Standards
- The Requirements
- Recognising the Problem
- Break
- The Problem Areas
- Quality Planning
- Question Time
- Lunch
- A Universal Quality Plan
- Break
- Inspection
- Test Methodology
- Management of Failure
- Question Time
- Close

OF LSPM Test Configuration

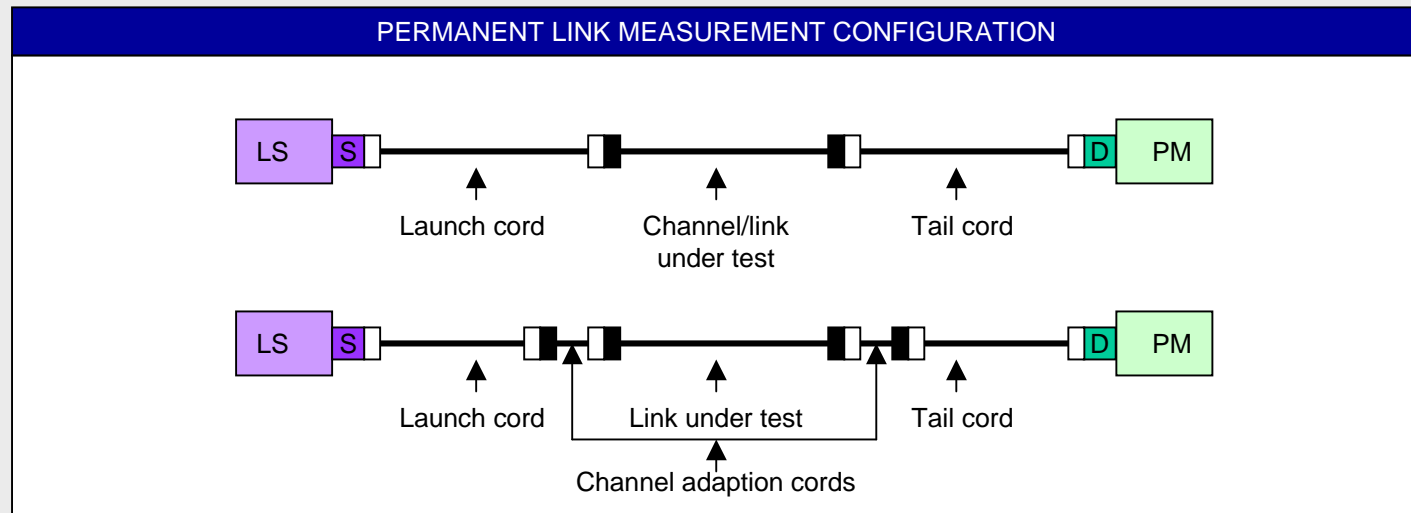

AGENDA

- Introduction
- The Standards
- The Requirements
- Recognising the Problem
- Break
- The Problem Areas
- Quality Planning
- Question Time
- Lunch
- A Universal Quality Plan
- Break
- Inspection
- Test Methodology
- Management of Failure
- Question Time
- Close

OF OTDR Test Configuration

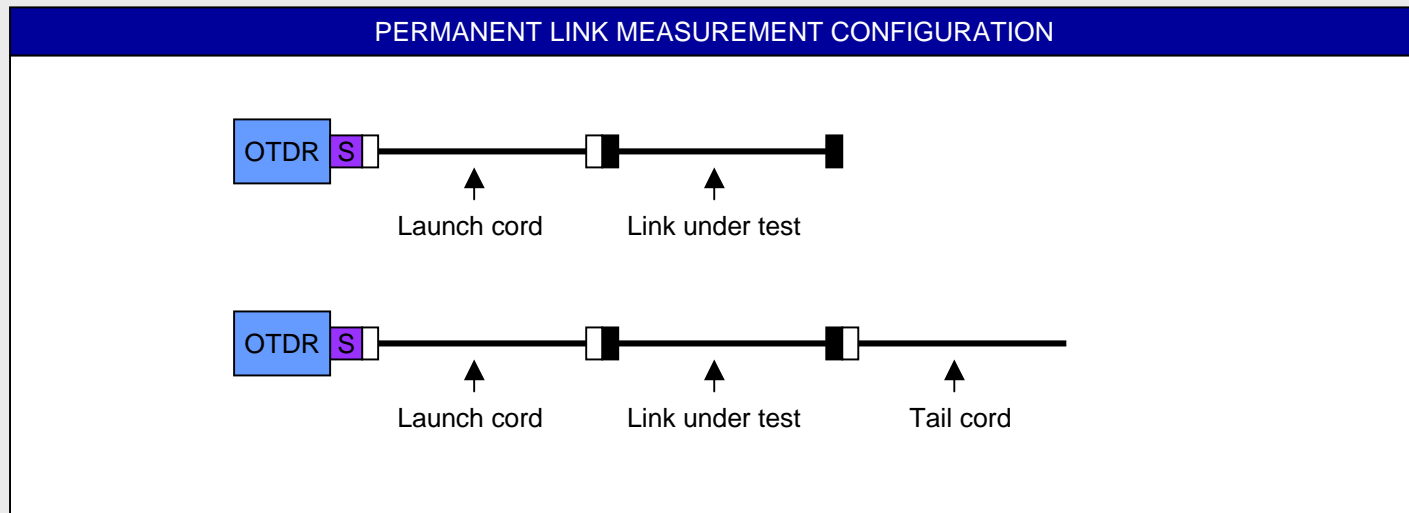

AGENDA

- Introduction
- The Standards
- The Requirements
- Recognising the Problem
- Break
- The Problem Areas
- Quality Planning
- Question Time
- Lunch
- A Universal Quality Plan
- Break
- Inspection
- Test Methodology
- Management of Failure
- Question Time
- Close

Administration of Test Cords

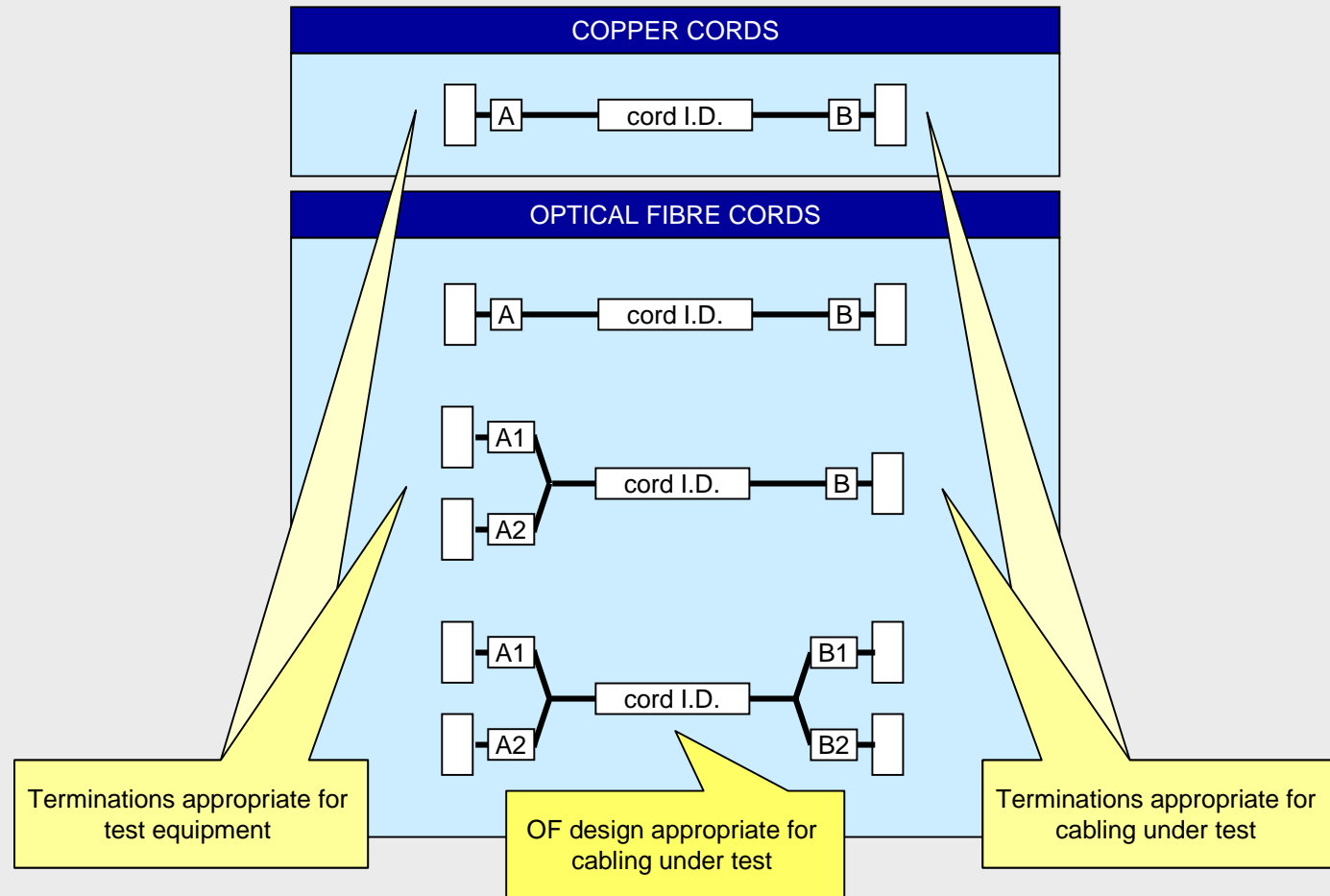

AGENDA

Introduction

The Standards

The Requirements

Recognising the Problem

Break

The Problem Areas

Quality Planning

Question Time

Lunch

A Universal Quality Plan

Break

Inspection

Test Methodology

Management of Failure

Question Time

Close

OF Test Cord Launch Conditions

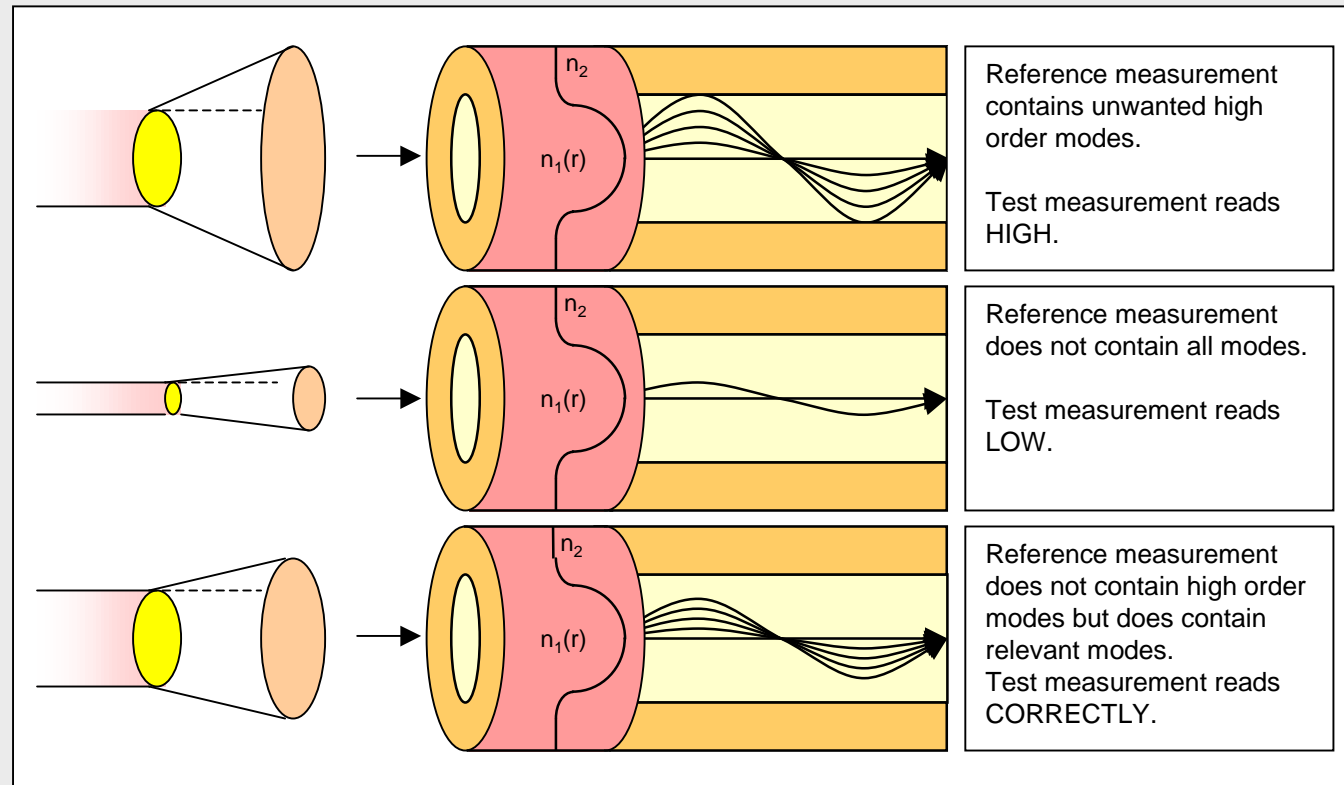

AGENDA

Introduction

The Standards

The Requirements

Recognising the Problem

Break

The Problem Areas

Quality Planning

Question Time

Lunch

A Universal Quality Plan

Break

Inspection

Test Methodology

Management of Failure

Question Time

Close

MMF Launch Cord Mandrel Wrap

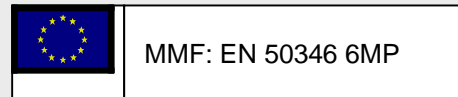
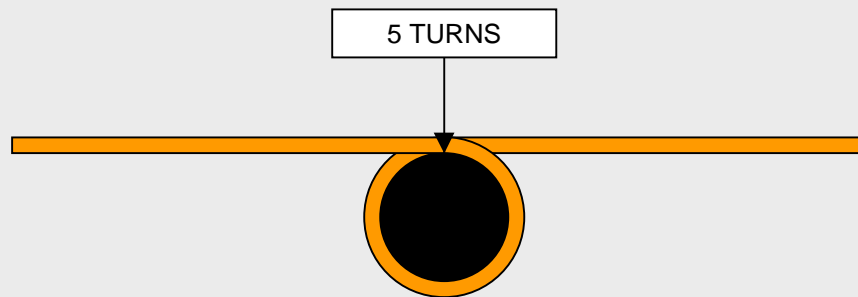

		Mandrel Diameter
50/125	Cable	18 mm
50/125	SCOF	15 mm
62.5/125	Cable	20 mm
62.5/125	SCOF	17 mm

AGENDA

Introduction

The Standards

The Requirements

Recognising the Problem

Break

The Problem Areas

Quality Planning

Question Time

Lunch

A Universal Quality Plan

Break

Inspection

Test Methodology

Management of Failure

Question Time

Close

Administration of Test Results

TEST CONFIGURATION RECORD

How is each test configuration identified?

- test equipment ID?
- local (launch) test cord?
- remote (tail) test cord?
 - dummy cord?
- channel adaption cords?

Local	End A to equipment
Remote	End A to equipment
Dummy	End A to local
CA	End B to link under test
01-xxx-49	

TEST RECORD

How is each test result identified?

- operator?
- date and time?
- test ID?

Operator	Initials
ID	Port ID/cable ID?

AGENDA

Introduction

The Standards

The Requirements

Recognising the Problem

Break

The Problem Areas

Quality Planning

Question Time

Lunch

A Universal Quality Plan

Break

Inspection

Test Methodology

Management of Failure

Question Time

Close

Management of Test Results

TEST SYSTEM MANAGEMENT

- test cord usage?
- test equipment calibration status?

TREATMENT OF MARGINAL/FAILED RESULTS

- re-testing with different test leads?
- the use of a statistical approach?
 - simple acceptance?

AGENDA

Introduction
The Standards
The Requirements
Recognising the Problem
Break
The Problem Areas
Quality Planning
Question Time
Lunch
A Universal Quality Plan
Break
Inspection
Test Methodology
Management of Failure
Question Time
Close

Delivery of Test Results

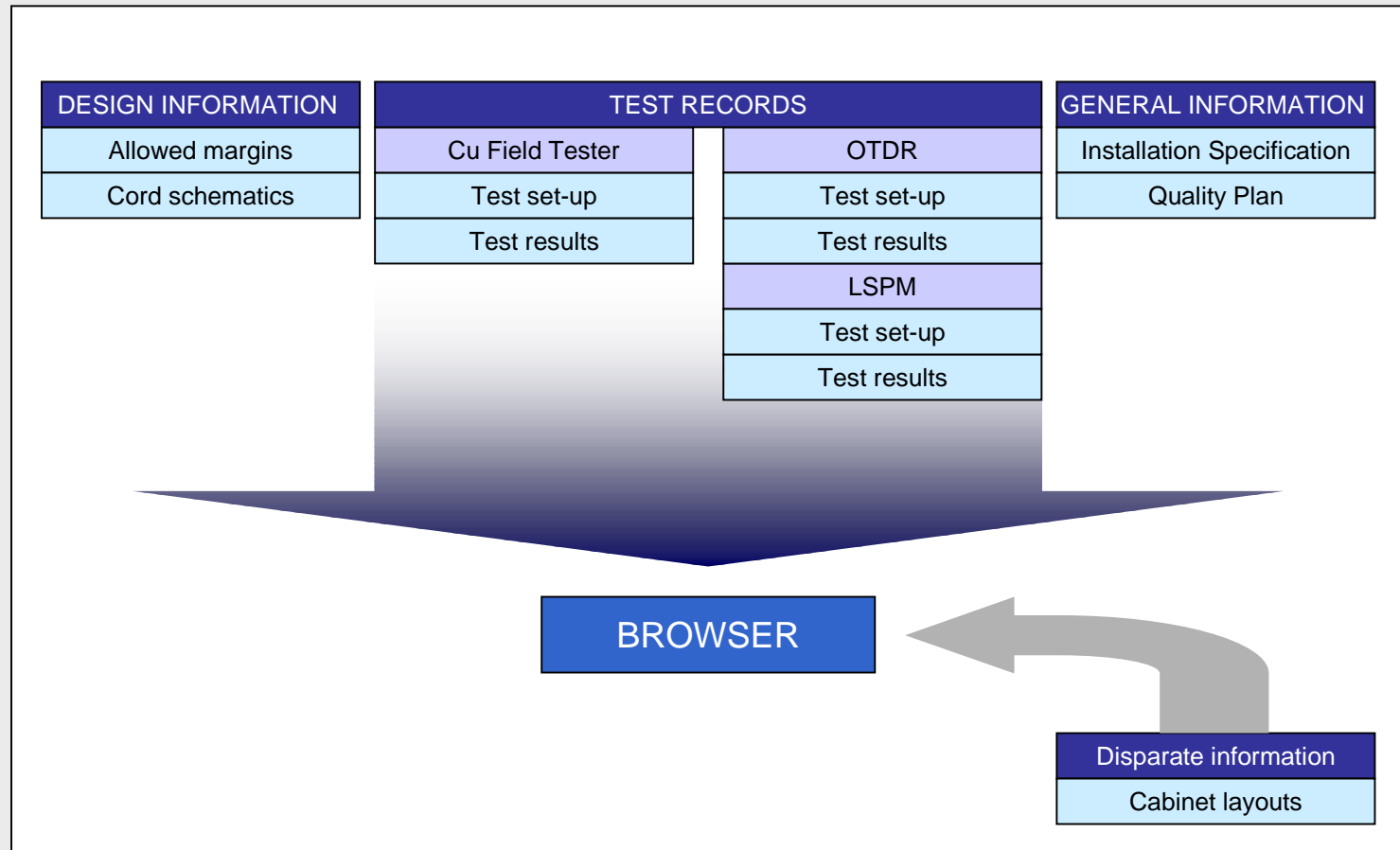

AGENDA

Introduction

The Standards

The Requirements

Recognising the Problem

Break

The Problem Areas

Quality Planning

Question Time

Lunch

A Universal Quality Plan

Break

Inspection

Test Methodology

Management of Failure

Question Time

Close

Break

AGENDA

Introduction

The Standards

The Requirements

Recognising the Problem

Break

The Problem Areas

Quality Planning

Question Time

Lunch

A Universal Quality Plan

Break

Inspection

Test Methodology

Management of Failure

Question Time

Close

Inspection

Inspection

Inspection Microscopes

Inspection of Connector End-faces

AGENDA

Introduction

The Standards

The Requirements

Recognising the Problem

Break

The Problem Areas

Quality Planning

Question Time

Lunch

A Universal Quality Plan

Break

Inspection

Test Methodology

Management of Failure

Question Time

Close

Inspection

EN 50174-1/ -2 AND MANUFACTURERS INSTRUCTIONS

Cable bend radii
(fixed cables and cords)

Cable sheath deformation

Copper pair untwist at termination

Optical fibre management within panels

Optical fibre polarity

Optical fibre end-face inspection
(not totally suitable for pre-polished terminations)

AGENDA

Introduction

The Standards

The Requirements

Recognising the Problem

Break

The Problem Areas

Quality Planning

Question Time

Lunch

A Universal Quality Plan

Break

Inspection

Test Methodology

Management of Failure

Question Time

Close

Inspection Microscopes



Priorscope (200x or 400 x)
Fitted with appropriate filters for Class 1M Hazard



Priorscope II (200x or 400 x)
Fitted with appropriate filters for Class 1M Hazard

AGENDA

- Introduction
- The Standards
- The Requirements
- Recognising the Problem
- Break
- The Problem Areas
- Quality Planning
- Question Time
- Lunch
- A Universal Quality Plan
- Break
- Inspection
- Test Methodology
- Management of Failure
- Question Time
- Close

Inspection of Connector End-faces

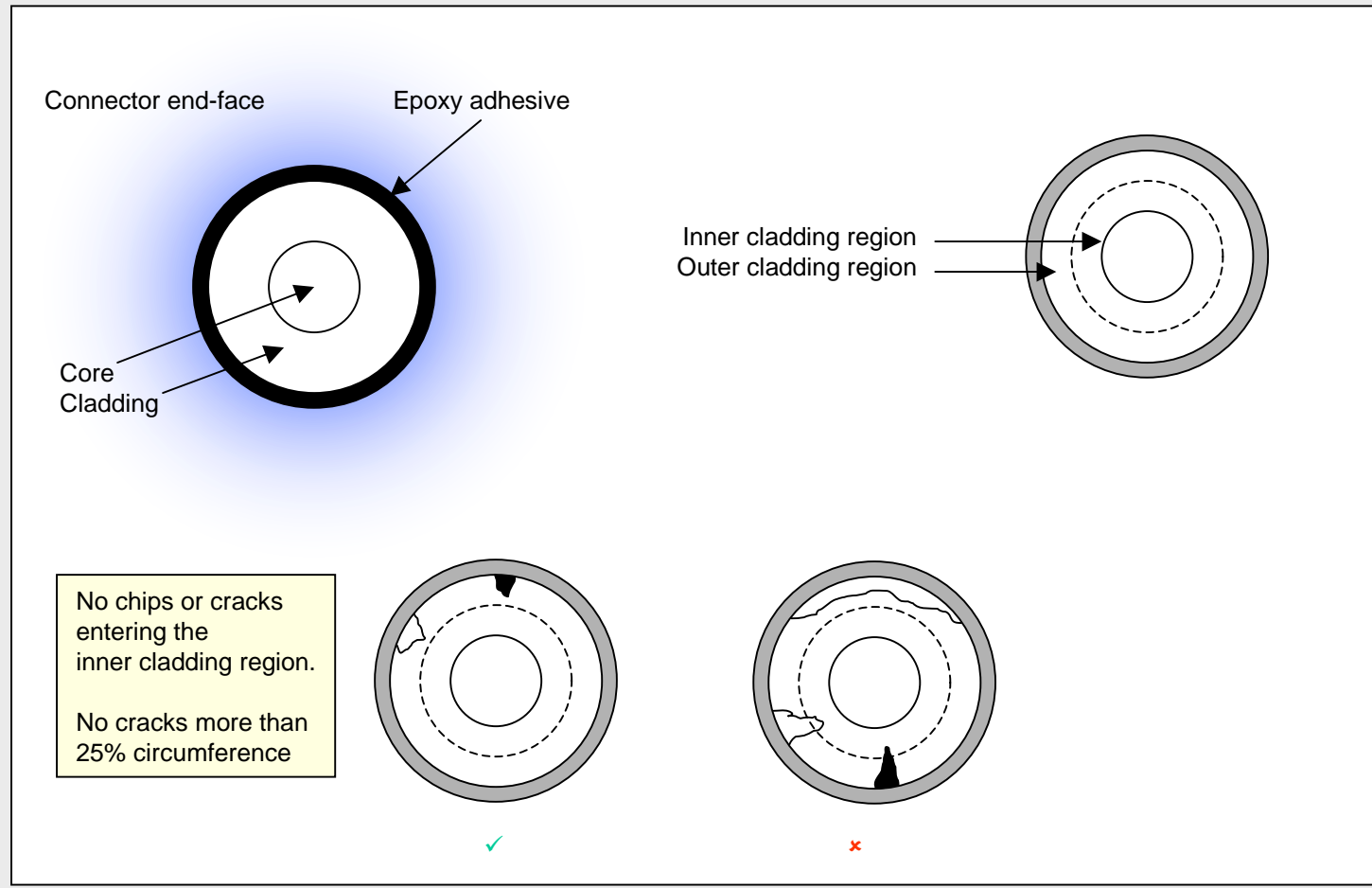

AGENDA

Introduction

The Standards

The Requirements

Recognising the Problem

Break

The Problem Areas

Quality Planning

Question Time

Lunch

A Universal Quality Plan

Break

Inspection

Test Methodology

Management of Failure

Question Time

Close

Copper

Optical Fibre

Test Methodology

AGENDA

Introduction

The Standards

The Requirements

Recognising the Problem

Break

The Problem Areas

Quality Planning

Question Time

Lunch

A Universal Quality Plan

Break

Inspection

Test Methodology

Management of Failure

Question Time

Close

Copper

Copper Test Methodology
Complex Links and Channels

AGENDA

Introduction

The Standards

The Requirements

Recognising the Problem

Break

The Problem Areas

Quality Planning

Question Time

Lunch

A Universal Quality Plan

Break

Inspection

Test Methodology

Management of Failure

Question Time

Close

Copper Test Methodology

PERMANENT LINK MEASUREMENT CONFIGURATION

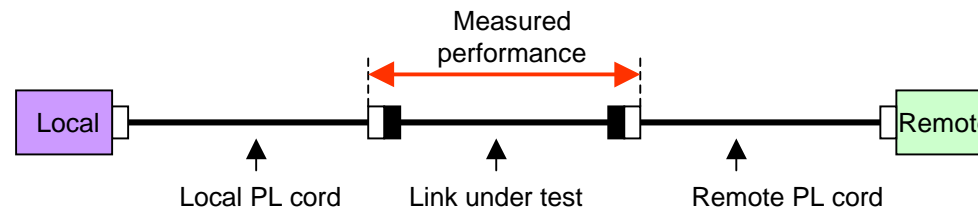

CHANNEL MEASUREMENT CONFIGURATION

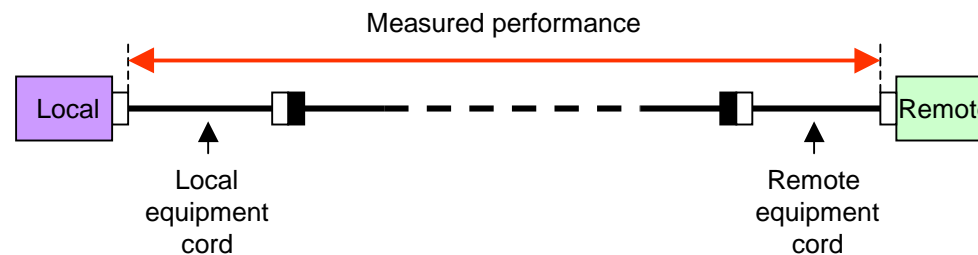

AGENDA

- Introduction
- The Standards
- The Requirements
- Recognising the Problem
- Break
- The Problem Areas
- Quality Planning
- Question Time
- Lunch
- A Universal Quality Plan
- Break
- Inspection
- Test Methodology
- Management of Failure
- Question Time
- Close

Complex Links and Channels

RETURN LOSS (PL and CHANNEL)	Diagram	NEXT/PSNEXT (PL)
<p>Possible marginal/fail results</p> <p>Minimize risk</p> <p>Use dissimilar lengths:</p> <ul style="list-style-type: none"> • test cords • CP cords • equipment cords • patch cords 		<p>Possible marginal results</p> <p>QA strategy required</p>

AGENDA

Introduction

The Standards

The Requirements

Recognising the Problem

Break

The Problem Areas

Quality Planning

Question Time

Lunch

A Universal Quality Plan

Break

Inspection

Test Methodology

Management of Failure

Question Time

Close

OF Test Methodology

Grade 1,3 LSPM - Configuration A
Grade 1,3 LSPM - Configuration B
Grade 1,3 LSPM - Configuration C
Grade 2 LSPM - Configuration A
Grade 4,5 LSPM
OTDR Measurement
OTDR Ghosts
LASER LSPM Equipment



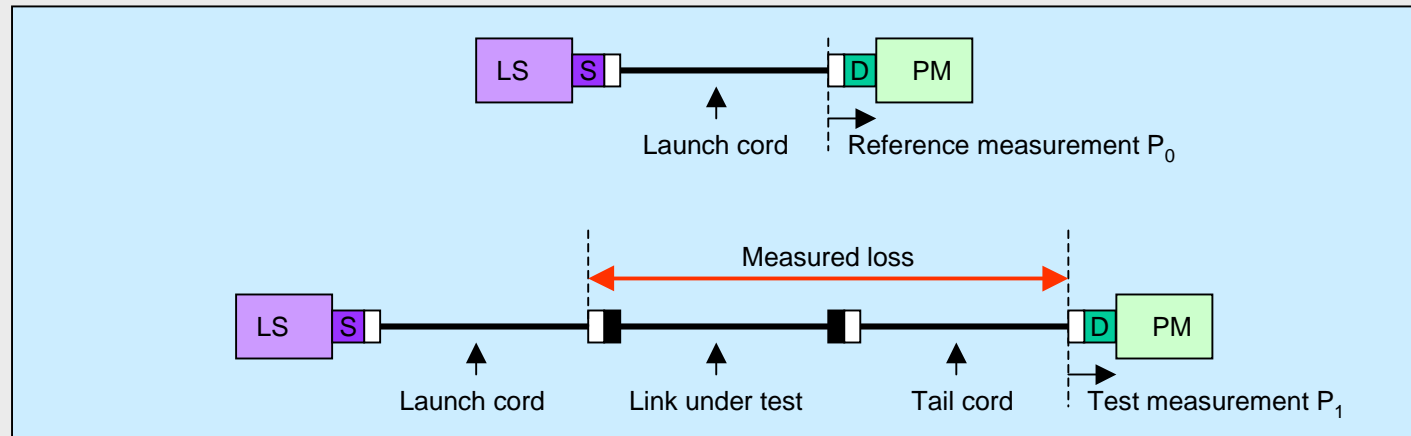
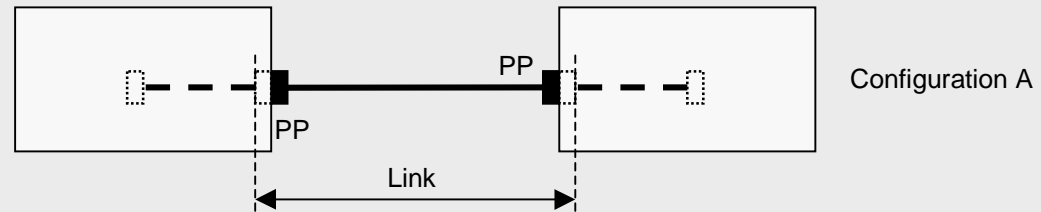

AGENDA

- Introduction
- The Standards
- The Requirements
- Recognising the Problem
- Break
- The Problem Areas
- Quality Planning
- Question Time
- Lunch
- A Universal Quality Plan
- Break
- Inspection
- Test Methodology
- Management of Failure
- Question Time
- Close

Grade 1,3 LSPM - Configuration A



$$\text{Loss} = P_1 - P_0 \text{ (dB)}$$

	MMF: IEC 61280-4-1 Method 2		MMF: EN 50346 Method 1		MMF:-526-14-A Method B
	SMF: IEC 61280-4-2 Method 1.A		SMF: IEC 61280-4-2 Method 1.A		SMF:-526-7 Method A.1
			BS 7718: Configuration A		



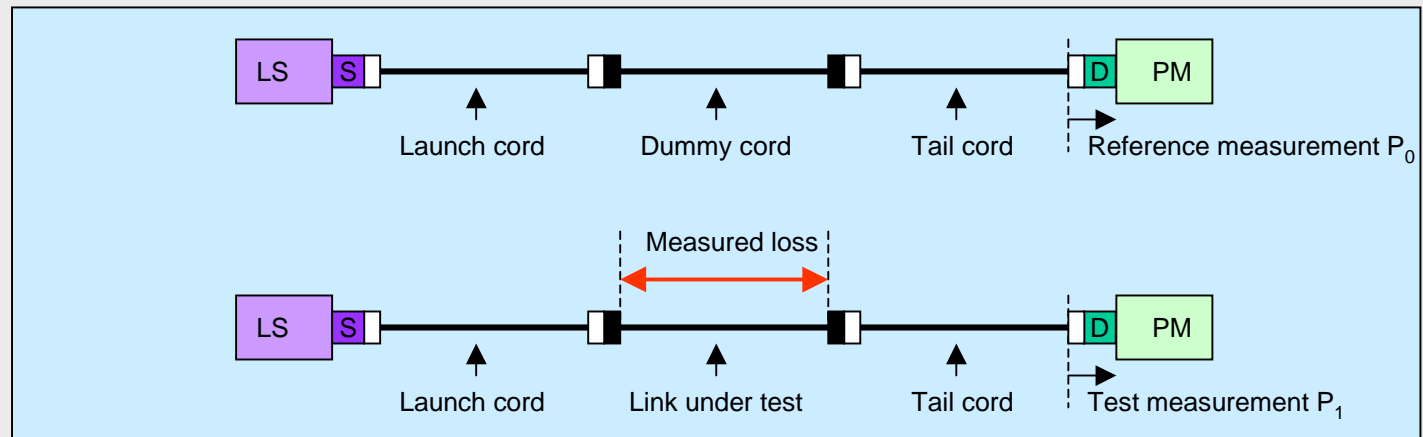
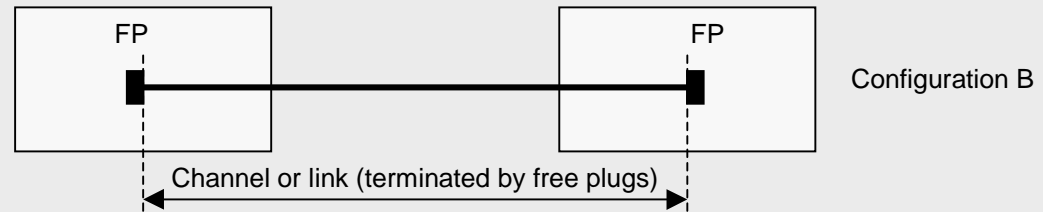

AGENDA

- Introduction
- The Standards
- The Requirements
- Recognising the Problem
- Break
- The Problem Areas
- Quality Planning
- Question Time
- Lunch
- A Universal Quality Plan
- Break
- Inspection
- Test Methodology
- Management of Failure
- Question Time
- Close

Grade 1,3 LSPM - Configuration B



$$\text{Loss} = P_1 - P_0 \text{ (dB)}$$

	MMF: IEC 61280-4-1 Method 3 SMF: IEC 61280-4-2 Method 1.C		MMF: EN 50346 Method 2 SMF: IEC 61280-4-2 Method 1.C		MMF:-526-14-A Method C SMF:-526-7 Method A.3
			BS 7718: Configuration B		

AGENDA

- Introduction
- The Standards
- The Requirements
- Recognising the Problem
- Break
- The Problem Areas
- Quality Planning
- Question Time
- Lunch
- A Universal Quality Plan
- Break
- Inspection
- Test Methodology
- Management of Failure
- Question Time
- Close

Grade 1,3 LSPM - Configuration C

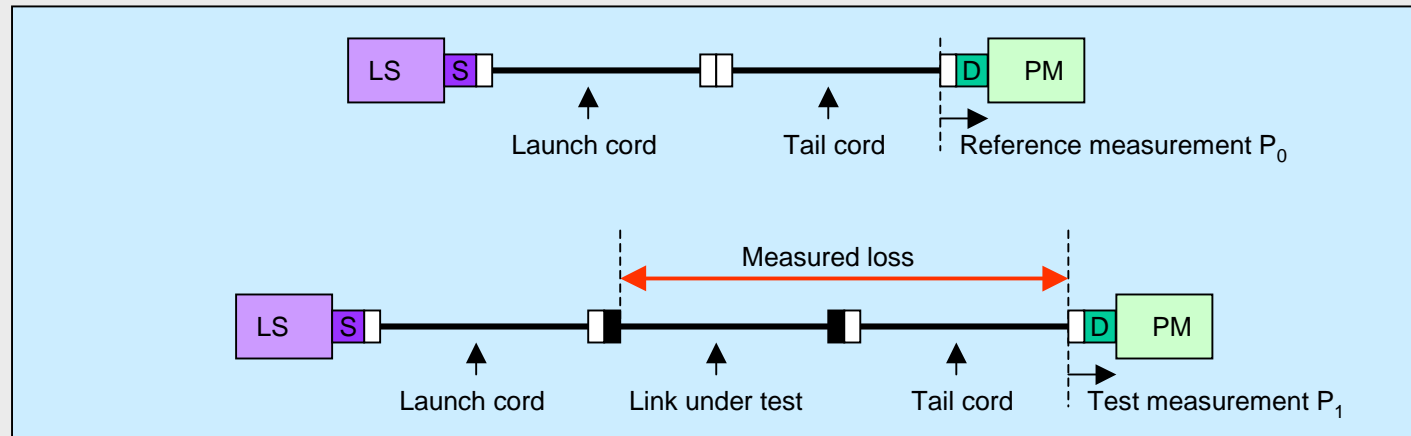
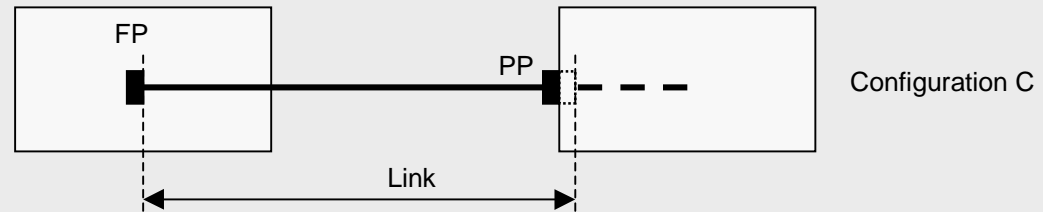

Loss = $P_1 - P_0$ (dB)



MMF: IEC 61280-4-1 Method 1
SMF: IEC 61280-4-2 Method 1.B



MMF:-526-14-A Method A
SMF:-526-7 Method A.2



BS 7718: Configuration C

AGENDA

- Introduction
- The Standards
- The Requirements
- Recognising the Problem
- Break
- The Problem Areas
- Quality Planning
- Question Time
- Lunch
- A Universal Quality Plan
- Break
- Inspection
- Test Methodology
- Management of Failure
- Question Time
- Close

Grade 2 LSPM - Configuration A

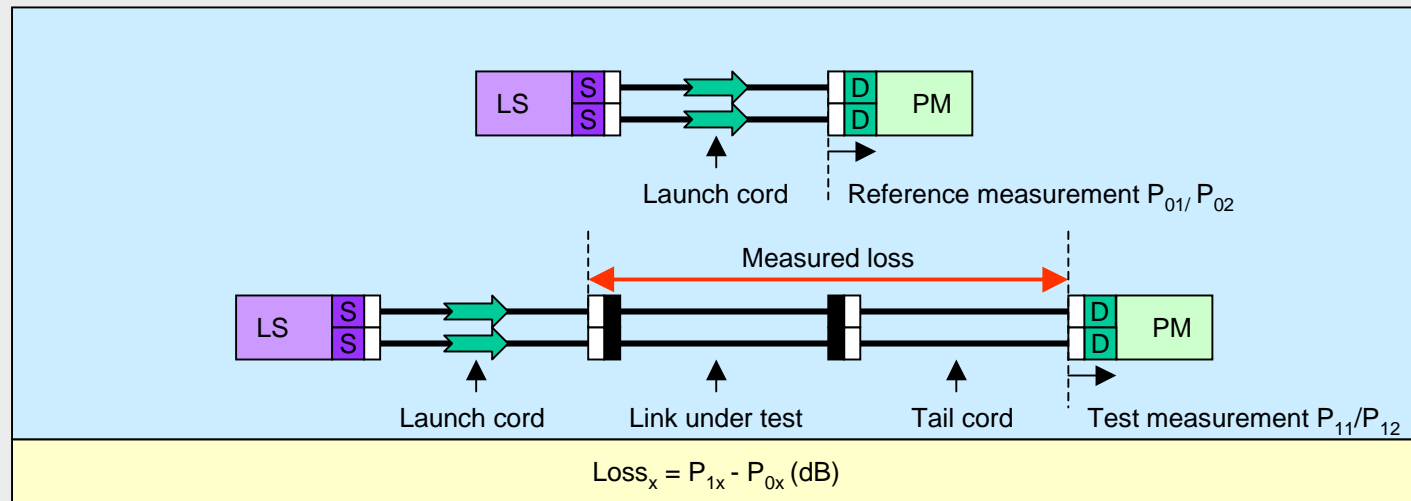
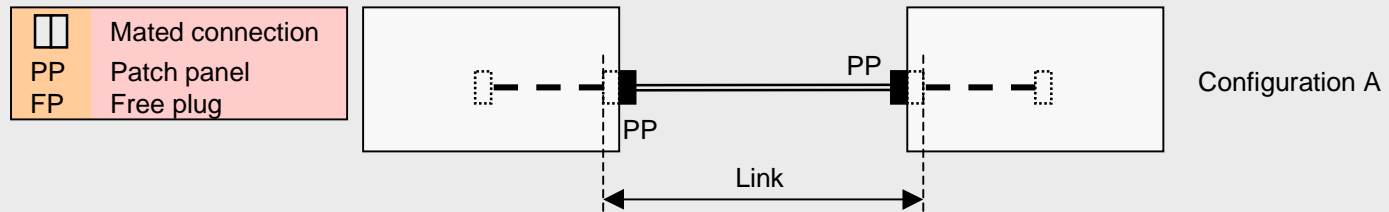

AGENDA

- Introduction
- The Standards
- The Requirements
- Recognising the Problem
- Break
- The Problem Areas
- Quality Planning
- Question Time
- Lunch
- A Universal Quality Plan
- Break
- Inspection
- Test Methodology
- Management of Failure
- Question Time
- Close

Grade 4,5 LSPM

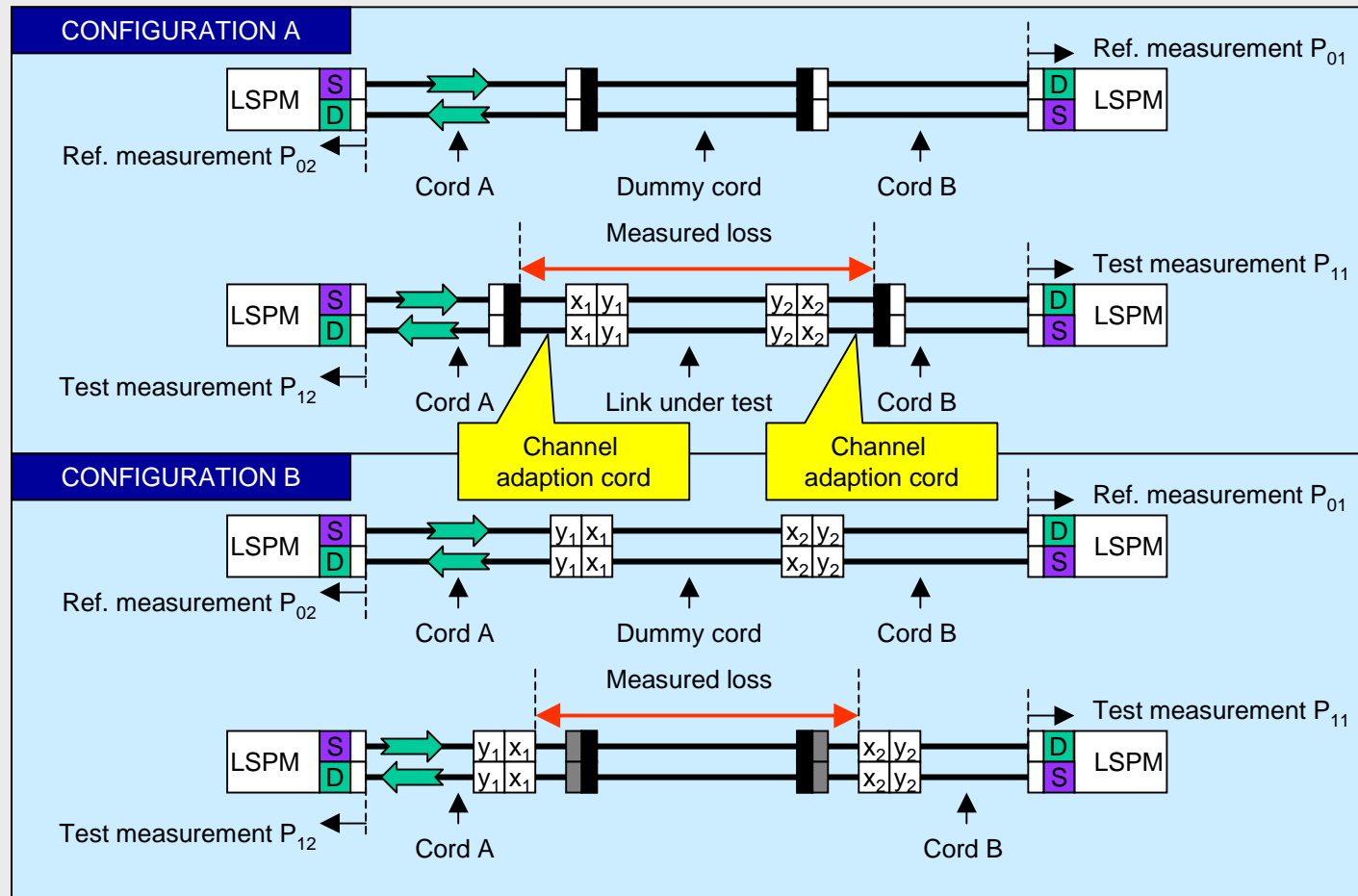

AGENDA

Introduction

The Standards

The Requirements

Recognising the Problem

Break

The Problem Areas

Quality Planning

Question Time

Lunch

A Universal Quality Plan

Break

Inspection

Test Methodology

Management of Failure

Question Time

Close

OTDR Measurement

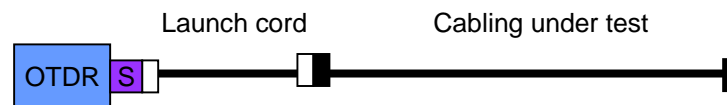

The single-ended measurement of a link:

- provides information about the general quality of the local interface
- provides information about the quality of the installed cable and any embedded joints;
- does not allow any quantitative measurement of the interfaces;
- does not allow any quantitative measurement of embedded joints
 - unless measurements are taken in both directions;
- does not provide any continuity measurement for the link as a whole.

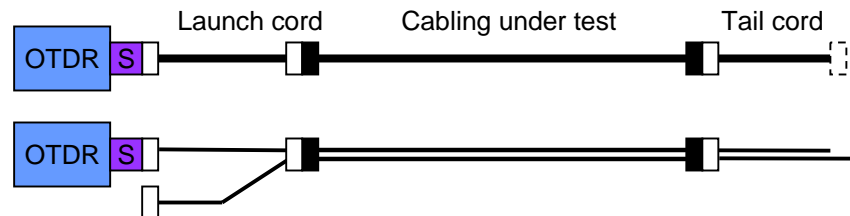

The double-ended measurement of a link:

- provides information about the general quality of both the local and remote interface
- provides information about the quality of the installed cable and any embedded joints;
- does not allow any quantitative measurement of the interfaces and embedded joints
 - unless measurements are taken in both directions;
- provides continuity measurement for the link as a whole.

Any measurements are subject to the same measurement accuracy as LSPM measurements.

AGENDA

- Introduction
- The Standards
- The Requirements
- Recognising the Problem
- Break
- The Problem Areas
- Quality Planning
- Question Time
- Lunch
- A Universal Quality Plan
- Break
- Inspection
- Test Methodology
- Management of Failure
- Question Time
- Close

OTDR Ghosts

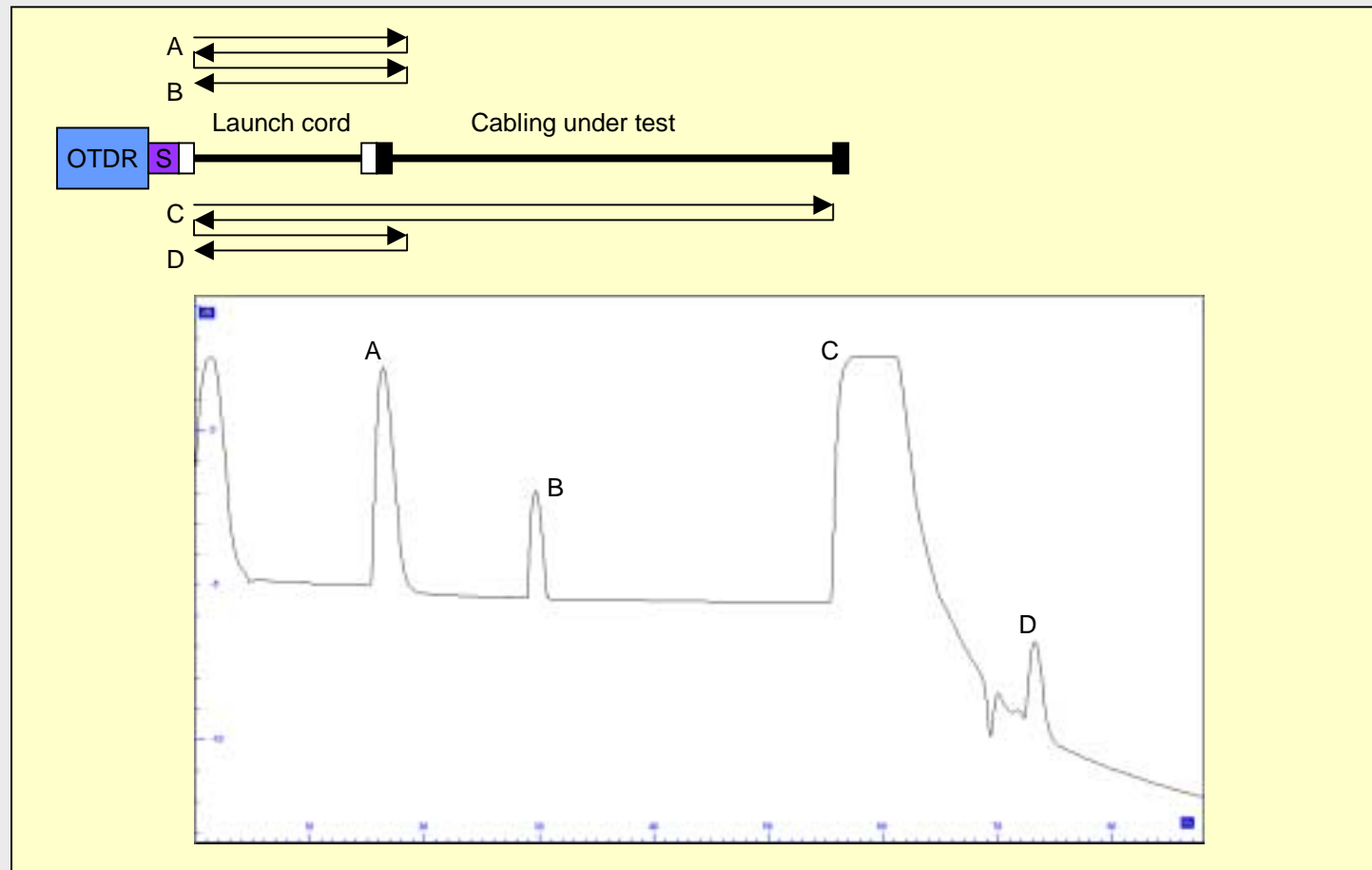

AGENDA

Introduction

The Standards

The Requirements

Recognising the Problem

Break

The Problem Areas

Quality Planning

Question Time

Lunch

A Universal Quality Plan

Break

Inspection

Test Methodology

Management of Failure

Question Time

Close

OTDR Poltergeists

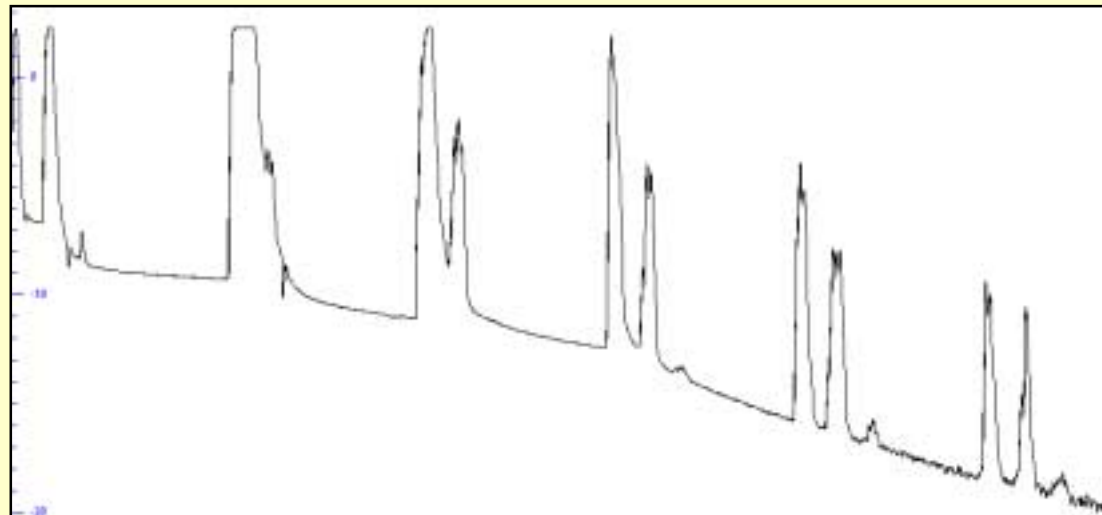

AGENDA

- Introduction
- The Standards
- The Requirements
- Recognising the Problem
- Break
- The Problem Areas
- Quality Planning
- Question Time
- Lunch
- A Universal Quality Plan
- Break
- Inspection
- Test Methodology
- Management of Failure
- Question Time
- Close

LASER LSPM Equipment

There is an argument to suggest that MMF cabling to support LASER-based applications should be tested with LASER sources

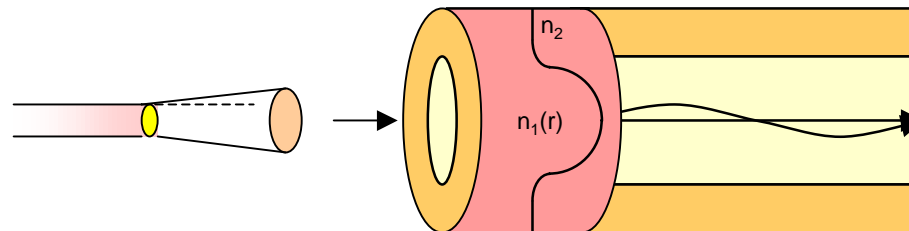

Reference measurement does not contain all modes.

Test measurement reads LOW.

Test results can vary with test lead handling.

Unless explicitly allowed and documented such equipment should not be used

AGENDA

Introduction

The Standards

The Requirements

Recognising the Problem

Break

The Problem Areas

Quality Planning

Question Time

Lunch

A Universal Quality Plan

Break

Inspection

Test Methodology

Management of Failure

Question Time

Close

Management of Failure

Implement Design Strategy

Copper

Identify Risk

Develop QA Strategy

Optical Fibre

Cleaning Materials

Accept the Inevitable

AGENDA

- Introduction
- The Standards
- The Requirements
- Recognising the Problem
- Break
- The Problem Areas
- Quality Planning
- Question Time
- Lunch
- A Universal Quality Plan
- Break
- Inspection
- Test Methodology
- Management of Failure
- Question Time
- Close

Implement Design Strategy

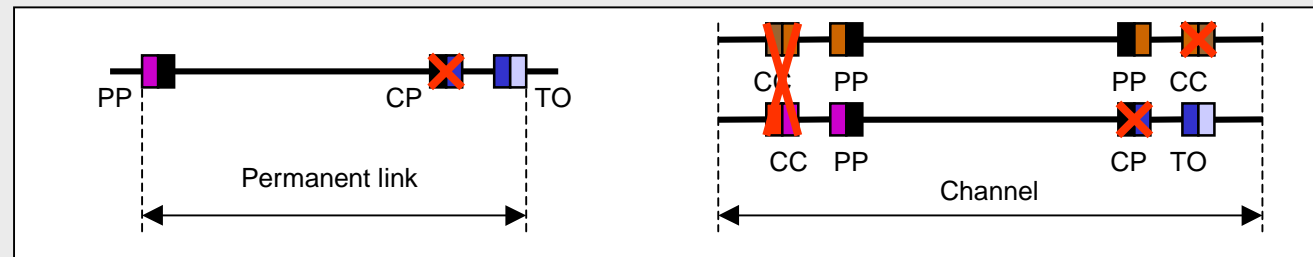

AGENDA

- Introduction
- The Standards
- The Requirements
- Recognising the Problem
- Break
- The Problem Areas
- Quality Planning
- Question Time
- Lunch
- A Universal Quality Plan
- Break
- Inspection
- Test Methodology
- Management of Failure
- Question Time
- Close

Copper: Identify Risk

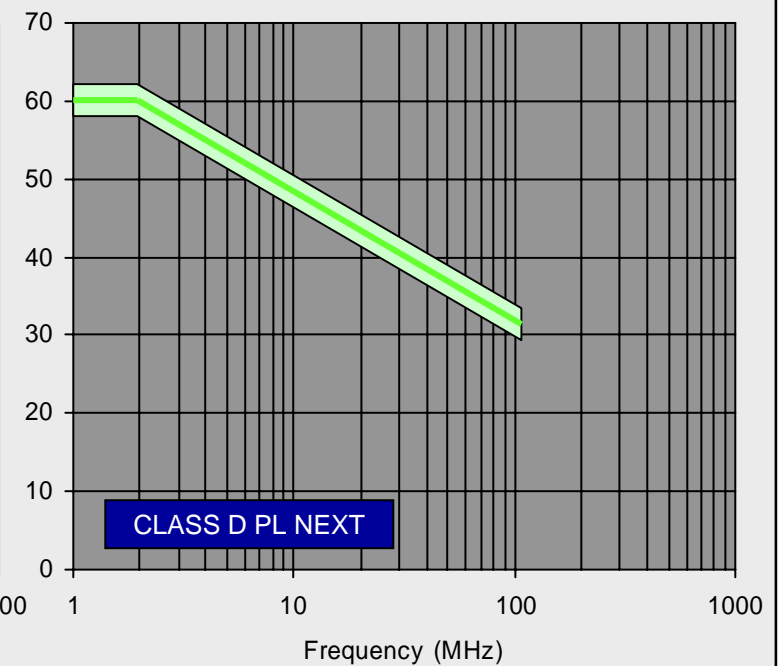
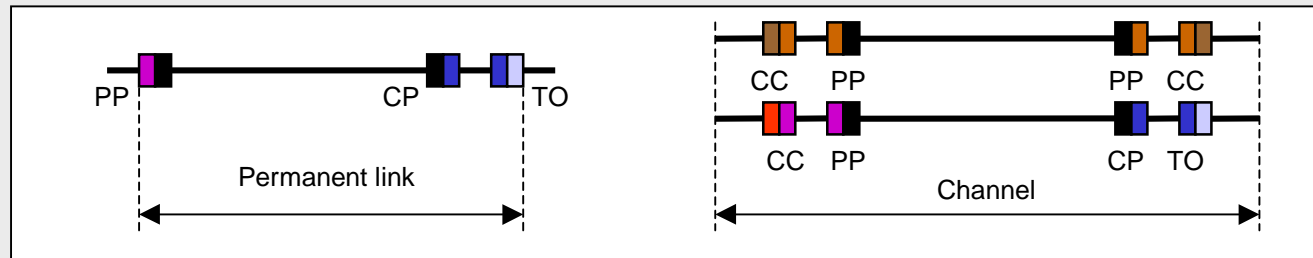

AGENDA

- Introduction
- The Standards
- The Requirements
- Recognising the Problem
- Break
- The Problem Areas
- Quality Planning
- Question Time
- Lunch
- A Universal Quality Plan
- Break
- Inspection
- Test Methodology
- Management of Failure
- Question Time
- Close

Copper: Develop QA Strategy

NEXT/PSNEXT (PL)

Possibility of marginal results on 3 connector permanent links (close proximity)

Short lengths resolved by test equipment using ISO/IEC and EN "get-out" clause
(not present in ANSI/TIA/EIA-568-B.1)

Long lengths (PP-CP) shall at least meet channel values of NEXT/PSNEXT

Ensure that overall length can provide adequate ACR/PSACR

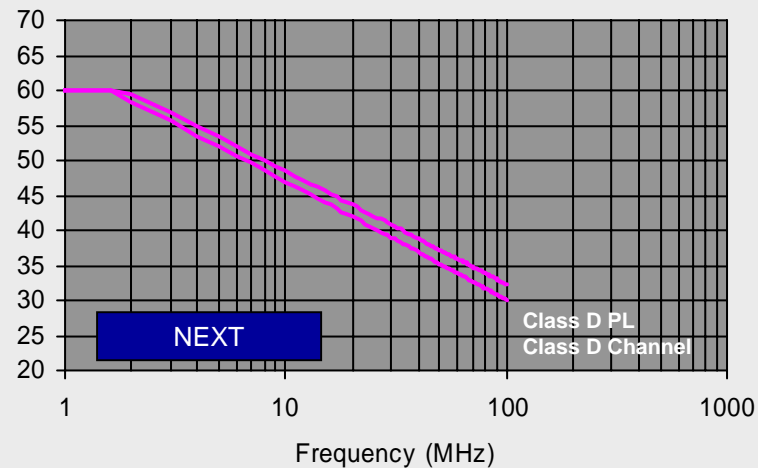

AGENDA

Introduction

The Standards

The Requirements

Recognising the Problem

Break

The Problem Areas

Quality Planning

Question Time

Lunch

A Universal Quality Plan

Break

Inspection

Test Methodology

Management of Failure

Question Time

Close

Copper: Develop QA Strategy

RETURN LOSS (PL AND CHANNEL)

Possibility of marginal/fail results on 3 connector permanent links and channels

Short lengths resolved by test equipment using ISO/IEC and EN "get-out" clause

Implement re-test procedure with different test cords (to restrict the impedance variation)

Implement re-test procedure with different CP cords/patch cords/equipment cords
(to restrict the impedance variation)

AGENDA

Introduction

The Standards

The Requirements

Recognising the Problem

Break

The Problem Areas

Quality Planning

Question Time

Lunch

A Universal Quality Plan

Break

Inspection

Test Methodology

Management of Failure

Question Time

Close

OF: Cleaning Materials

IPA (Iso-Propyl Alcohol)
• general purpose cleaning agent

Lint-free wipes

Lint-free cotton buds

IPA Wipes



AGENDA

- Introduction
- The Standards
- The Requirements
- Recognising the Problem
- Break
- The Problem Areas
- Quality Planning
- Question Time
- Lunch
- A Universal Quality Plan
- Break
- Inspection
- Test Methodology
- Management of Failure
- Question Time
- Close

OF: Accept the Inevitable

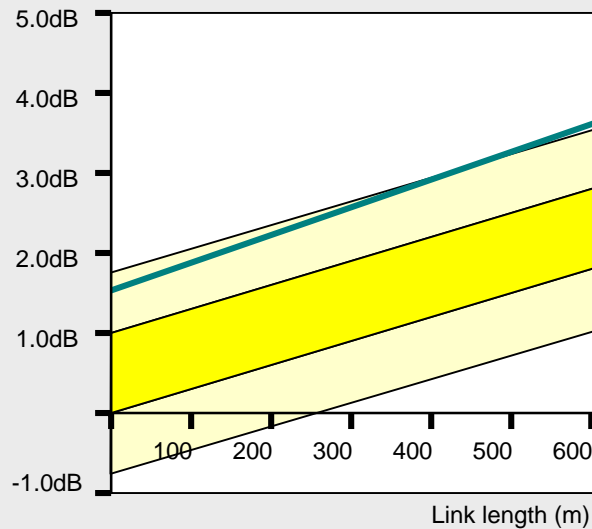

ATTENUATION

- Possibility of marginal/fail results
- Re-test using different cords
- Re-test using OTDR

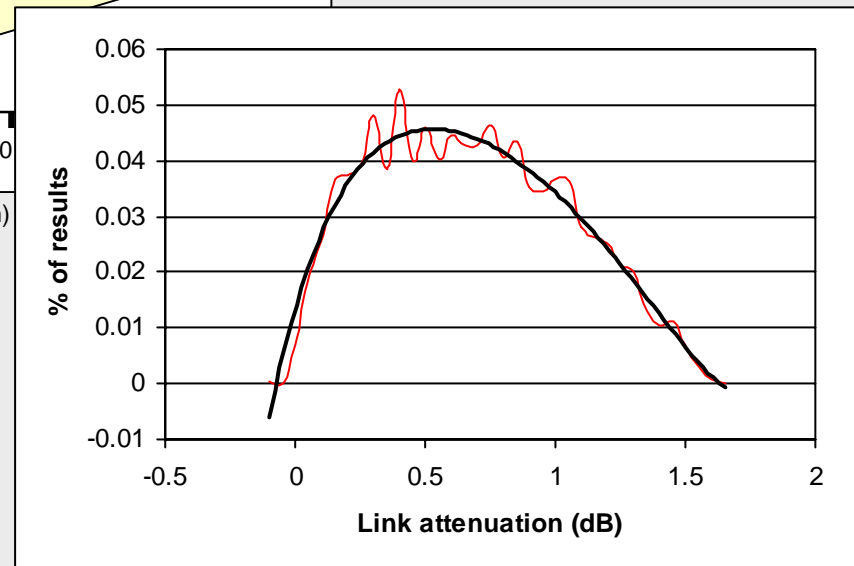

AGENDA

Introduction

The Standards

The Requirements

Recognising the Problem

Break

The Problem Areas

Quality Planning

Question Time

Lunch

A Universal Quality Plan

Break

Inspection

Test Methodology

Management of Failure

Question Time

Close

Management of Failure



AGENDA

Introduction

The Standards

The Requirements

Recognising the Problem

Break

The Problem Areas

Quality Planning

Question Time

Lunch

A Universal Quality Plan

Break

Inspection

Test Methodology

Management of Failure

Question Time

Close

Question Time

AGENDA

Introduction

The Standards

The Requirements

Recognising the Problem

Break

The Problem Areas

Quality Planning

Question Time

Lunch

A Universal Quality Plan

Break

Inspection

Test Methodology

Management of Failure

Question Time

Close

Close

- full colour copy of presentation
- www.it-cabling.com/gendocs/tge.pdf