

The New Generation of Optical Fibre Components

Prepared and delivered for



Edinburgh Hilton
11th October 2001

AGENDA

Introduction

A Standards Update

Optical Fibre Categories

Backwards Compatibility

10GBASE-xyz

SFF Connecting Hardware

Testing the New Cabling

Question Time

Close

Mike Gilmore

The Cabling Partnership

www.it-cabling.com

e-Ready Building

www.e-readybuilding.com

PO Box MT65, LEEDS, LS17 8YD, United Kingdom

Tel: +44 (0) 113 232 3721 Fax: +44 (0) 113 232 3724

Mike Gilmore



ISO/IEC JTC1 SC25

Secretary: WG3: Generic Cabling

Member: Project Team: SOHO



BSI

Chairman TCT7/-/1: IT Cabling

Chairman TCT7/-/3: IT Cabling



CENELEC

Convenor: TC215 WG1: IT Cabling

Fibreoptic Industry Association

Standards Director

Technical Director

FIA

The Fibreoptic Industry Association

AGENDA

- Introduction
- A Standards Update**
- Optical Fibre Categories
- Backwards Compatibility
- 10GBASE-xyz
- SFF Connecting Hardware
- Testing the New Cabling
- Question Time
- Close

A Standards Update

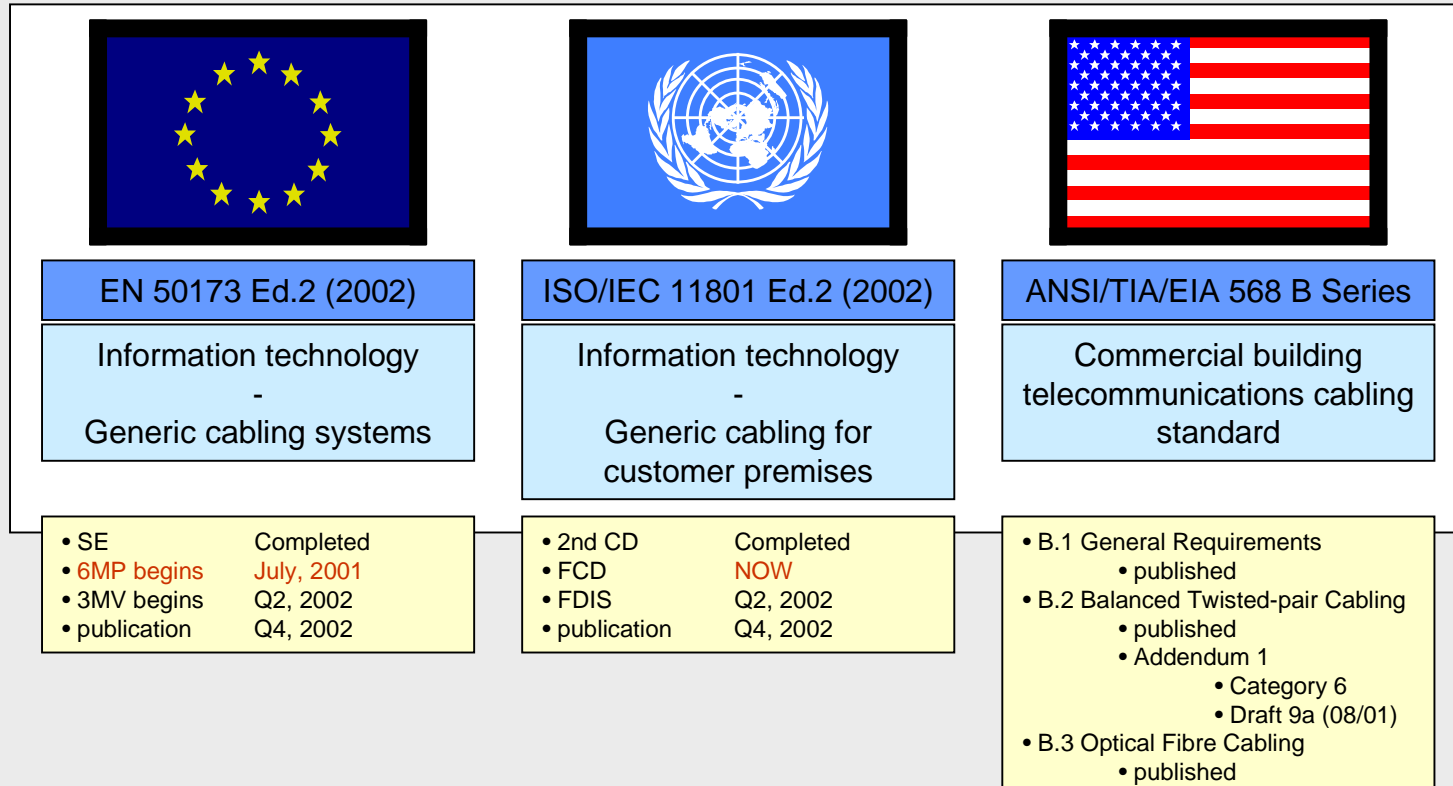

AGENDA

Introduction

A Standards Update

Optical Fibre Categories

Backwards Compatibility

10GBASE-xyz

SFF Connecting Hardware

Testing the New Cabling

Question Time

Close

FIA Documentation Update

DESIGN		
FIA-TSD-2000-1-1	OPTICAL FIBRE CABLING: LAN APPLICATION SUPPORT GUIDE	JANUARY 2001
	Revision to include mode conditioning cords and 10GBASE-xyz	JANUARY 2002
INSTALLATION		
FIA-TSD-2000-4-2-1	TESTING OF INSTALLED CABLING: ATTENUATION USING LSPM EQUIPMENT	JANUARY 2002
SAFETY		
FIA-TSD-2000-5-1	OPTICAL POWER: SAFETY LEVELS	DECEMBER 2001
FIA-TSD-2000-5-2	OPTICAL FIBRE: HANDLING OF PROCESSING CHEMICALS	
FIA-TSD-2000-5-3	OPTICAL FIBRE: DISPOSAL OF WASTE	

MODELLING TOOLS	
CABLING STRUCTURES COST MODEL	DECEMBER 2001

AGENDA

- Introduction
- A Standards Update
- Optical Fibre Categories
- Backwards Compatibility
- 10GBASE-xyz
- SFF Connecting Hardware
- Testing the New Cabling
- Question Time
- Close

Optical Fibre Categories

IT CABLING STANDARDS					
		Attenuation coefficient dBkm ⁻¹ max.		Modal bandwidth MHz.km min.	
		850nm	1300nm	850nm	1300nm
ISO/IEC 11801(1995)	50/125 and 62.5/125	3.5	1.0	200	500
EN 50173 (1995)	50/125 and 62.5/125	3.5	1.0	200	500
ANSI/TIA/EIA 568A (1995)	62.5/125	3.75	1.5	160	500

OPTICAL FIBRE STANDARDS (IEC 60793-X-X)								
Attenuation coefficient dBkm ⁻¹ max.			Modal bandwidth (OFL) MHz.km min.					
	850nm	1300nm	850nm	1300nm				
50/125	2.4	0.6	50/125	400	400	200	400	50/125 + 62.5/125
	2.5	0.8		400	600	200	600	
	2.7	1.0		400	800	160	200	62.5/125
62.5/125	3.0	0.7	400	1000	200	200		
	3.2	0.9	400	1200	250	1000		
			400	1500	300	800		
	600	1000						



AGENDA

- Introduction
- A Standards Update
- Optical Fibre Categories
- Backwards Compatibility
- 10GBASE-xyz
- SFF Connecting Hardware
- Testing the New Cabling
- Question Time
- Close

OFL/LL Modal Bandwidth

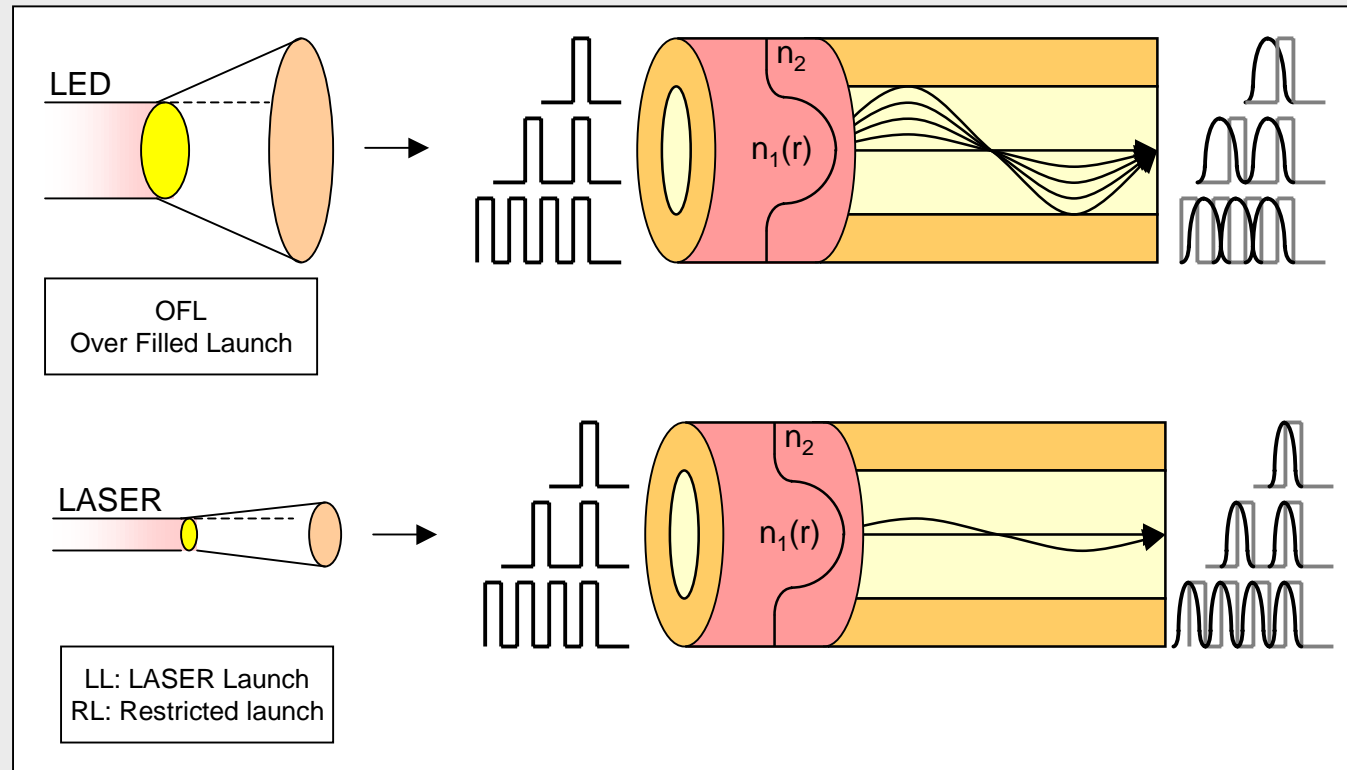

AGENDA

Introduction

A Standards Update

Optical Fibre Categories

Backwards Compatibility

10GBASE-xyz

SFF Connecting Hardware



Testing the New Cabling

Question Time

Close

Optical Fibre Categories

IT CABLING STANDARDS



	ISO/IEC 11801 Ed. 2 (2002)		EN 50173 Ed. 2 (2002)
	2nd CDV: Document N696		6MP Document
			BS EN 50173 Ed. 2 (2002)

	Wavelength	Multimode OF			Wavelength	Singlemode OF
		50/125 or 62.5/125				
		OM1	OM2	OM3		OS1
Attenuation coefficient (dBkm ⁻¹ max)	850nm	3,5			1310nm	1,0
	1300nm	1,5			1550nm	1,0
Modal bandwidth OFL (MHz.km min)	850nm	200	500	500		
	1300nm	500	500	500		
Modal bandwidth LL (MHz.km min)	850nm	ffs	ffs	2000		
	1300nm	ffs	ffs	ffs		
Propagation delay (ns.m ⁻¹ max)	850nm	5			1310nm	5
	1300nm				1550nm	

AGENDA

- Introduction
- A Standards Update
- Optical Fibre Categories
- Backwards Compatibility
- 10GBASE-xyz
- SFF Connecting Hardware
- Testing the New Cabling
- Question Time
- Close

Optical Fibre Categories

IT CABLING STANDARDS			
	ISO/IEC 11801 Ed. 2 (2002)		EN 50173 Ed. 2 (2002)
	FCD: Document N739		Next draft
			BS EN 50173 Ed. 2 (2002)

	Wavelength	Multimode OF			Wavelength	Singlemode OF
		50/125 or 62.5/125		50/125		
		OM1	OM2	OM3		
Attenuation coefficient (dBkm ⁻¹ max)	850nm	3,5			1310nm	1,0
	1300nm	1,5			1550nm	1,0
Modal bandwidth OFL (MHz.km min)	850nm	200	500	1500		
	1300nm	500	500	500		
Modal bandwidth LL (MHz.km min)	850nm	-	-	2000		
	1300nm	-	-	-		
Propagation delay (ns.m ⁻¹ max)	850nm	5			1310nm	5
	1300nm				1550nm	

Legacy OF

Legacy OF

AGENDA

Introduction

A Standards Update

Optical Fibre Categories

Backwards Compatibility

10GBASE-xyz

SFF Connecting Hardware

Testing the New Cabling

Question Time

Close

Backwards Compatibility

IT CABLING STANDARDS

	ISO/IEC 11801 Ed. 2 (2002)		EN 50173 Ed. 2 (2002)
	FCD: Document N739		Next draft
			BS EN 50173 Ed. 2 (2002)
No explicit requirements are stated			

Experience to date

No processing problems splicing between OM1/OM2 and OM3

Insertion loss of splices between OM1/OM2 and OM3 remains OK

Insertion loss of connections between OM1/OM2 and OM3 remains OK

Testing OM3 with OM1/OM2 test leads provides logical results

All the above assume that the 50/125µm is used

AGENDA

- Introduction
- A Standards Update
- Optical Fibre Categories
- Backwards Compatibility
- 10GBASE-xyz
- SFF Connecting Hardware
- Testing the New Cabling
- Question Time
- Close

10GBASE-xyz

IEEE 802.3ae (completion June 2002)

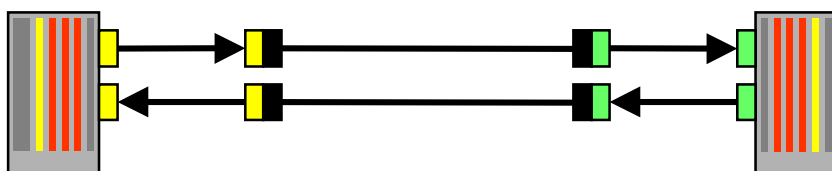

- switched operation only
- star topology
- support 10Gb/s Ethernet and 9.584640Gb/s SONET
- 2000 m, 10000 m and 40000 m over SMF
- 100 m over existing MMF

		Range	OF	λ	Cable	Protocol	
SAN	Legacy support	< 33 m	MMF	850	OM1	Serial	10GBASE-SR
		< 82 m	MMF	850	OM2	Serial	10GBASE-SR
LAN		< 300 m	MMF	850	OM3	Serial	10GBASE-SR/SW
L/M/WAN	Legacy support	< 300 m	MMF	1300	OMx	CWDM	10GBASE-LX4
		< 10000 m	SMF	1310	OS1	Serial	10GBASE-LR/LW
		< 40000 m	SMF	1550	OS1	Serial	10GBASE-ER/EW

AGENDA

- Introduction
- A Standards Update
- Optical Fibre Categories
- Backwards Compatibility
- 10GBASE-xyz
- SFF Connecting Hardware
- Testing the New Cabling
- Question Time
- Close

100Mb/s Implementation

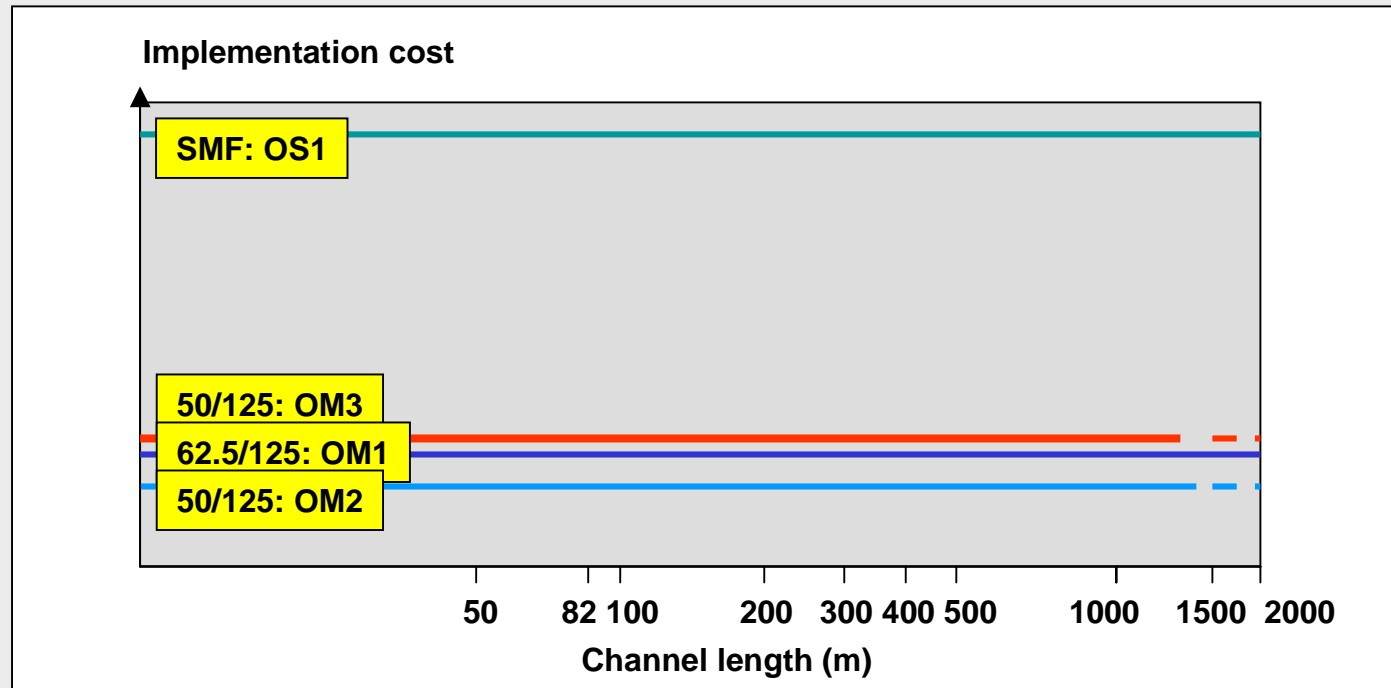

AGENDA

- Introduction
- A Standards Update
- Optical Fibre Categories
- Backwards Compatibility
- 10GBASE-xyz
- SFF Connecting Hardware
- Testing the New Cabling
- Question Time
- Close

1000Mb/s Implementation

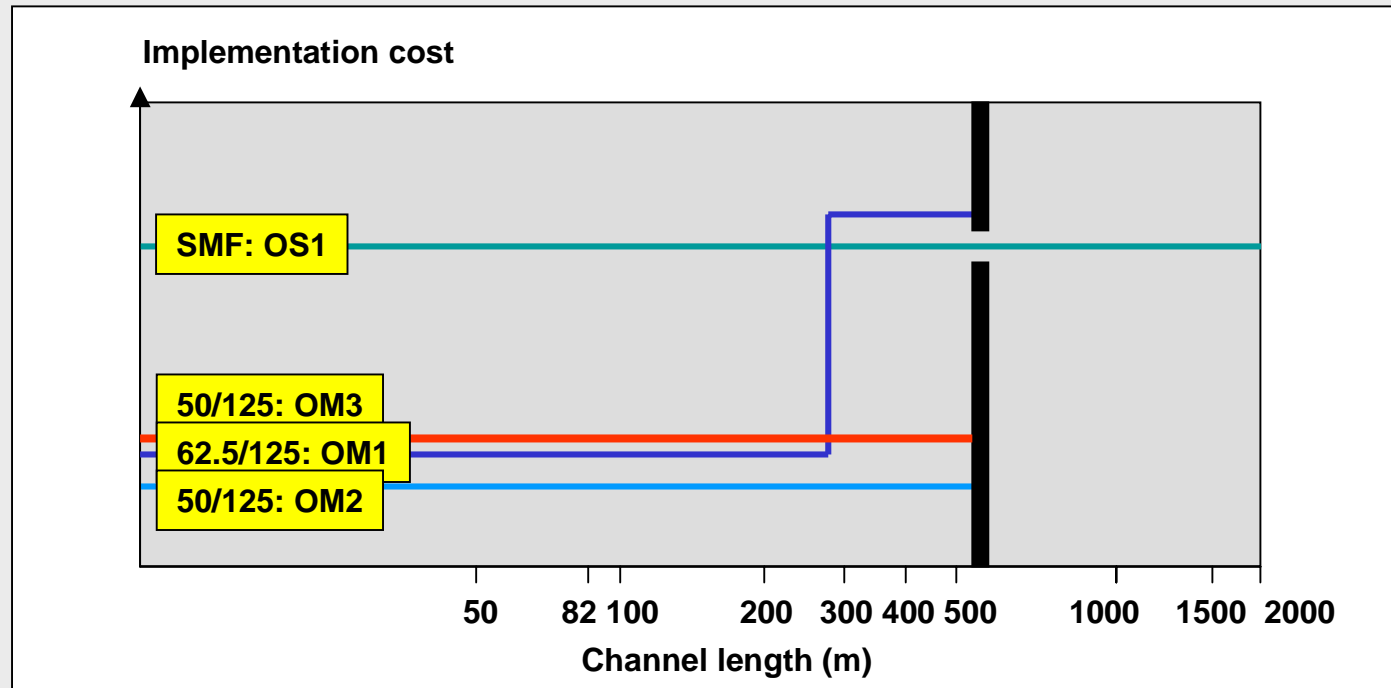

AGENDA

- Introduction
- A Standards Update
- Optical Fibre Categories
- Backwards Compatibility
- 10GBASE-xyz
- SFF Connecting Hardware
- Testing the New Cabling
- Question Time
- Close

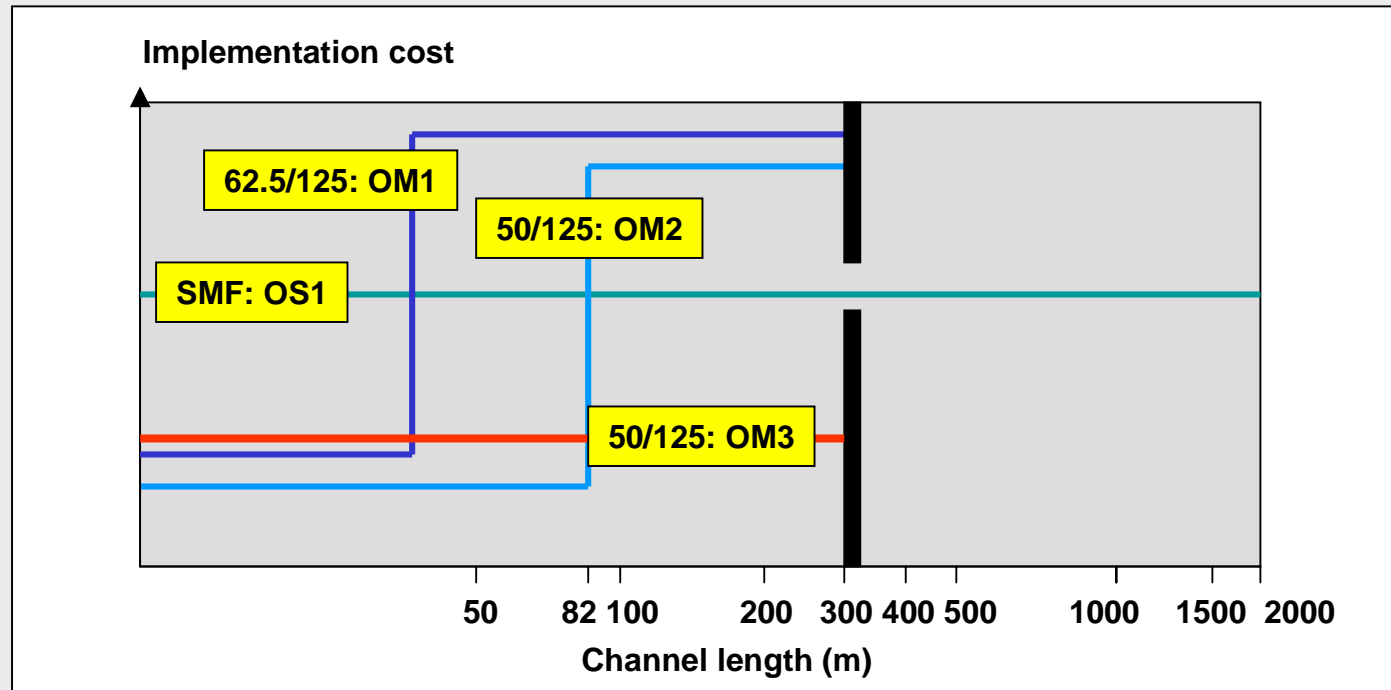

10000Mb/s Implementation



AGENDA

- Introduction
- A Standards Update
- Optical Fibre Categories
- Backwards Compatibility
- 10GBASE-xyz
- SFF Connecting Hardware
- Testing the New Cabling
- Question Time
- Close

SFF Connecting Hardware

IT CABLING STANDARDS			
	ISO/IEC 11801 Ed. 2 (2002)		EN 50173 Ed. 2 (2002)
	2nd CDV: Document N696		6MP Document BS EN 50173 Ed. 2 (2002)

Mating dimensions and gauging of TO connection	
SC Duplex	IEC 60874-19-1

	Wavelength	Multimode OF		Singlemode OF	
		Connection	Splice	Connection	Splice
Return loss (dB min)	All	20dB	NA	35dB	NA
Attenuation (dB max)	All	95%<0,5 100%<0,75	100%<0,3	95%<0,5 100%<0,75	100%<0,3

Requirements for areas other than the telecommunications outlet

The optical fibre connectors used shall meet the requirements ..., with exception of the physical dimensions.... In areas other than the work area, the choice of connecting hardware is open to all types of optical fibre connectors **standardized by IEC.**

When high density is an important consideration **Small Form Factor** connector designs that accommodate at least two fibres within the footprint of an EN 60603-7 connector are recommended.



However, where detail specifications produced by IEC or CENELEC in accordance with requirements of do not exist then **assurance should be sought from suppliers that the combinations of components** within connecting hardware are able to meet the optical and mechanical requirements of this clause.



AGENDA

- Introduction
- A Standards Update
- Optical Fibre Categories
- Backwards Compatibility
- 10GBASE-xyz
- SFF Connecting Hardware
- Testing the New Cabling
- Question Time
- Close

SFF Connecting Hardware

IT CABLING STANDARDS			
	ISO/IEC 11801 Ed. 2 (2002)		EN 50173 Ed. 2 (2002)
	2nd CDV: Document N696		6MP Document BS EN 50173 Ed. 2 (2002)

Mating dimensions and gauging of TO connection					
SC Duplex		IEC 60874-19-1			
	Wavelength	Multimode OF		Singlemode OF	
		Connection	Splice	Connection	Splice
Return loss (dB min)	All	20dB	NA	35dB	NA
Attenuation (dB max)	All	95%<0,5 100%<0,75	100%<0,3	95%<0,5 100%<0,75	100%<0,3

Requirements for areas other than the telecommunications outlet

The optical fibre connectors used shall meet the requirements ..., with exception of the physical dimensions.... In areas other than the work area, the choice of connecting hardware is open to all types of optical fibre connectors **standardized by IEC.**

When high density is an important consideration **Small Form Factor** connector designs that accommodate at least two fibres within the footprint of an EN 60603-7 connector are recommended. However, where detail specifications produced by IEC or CENELEC in accordance with requirements of do not exist then **assurance should be sought from suppliers that the combinations of components** within connecting hardware are able to meet the optical and mechanical requirements of this clause.



AGENDA

Introduction

A Standards Update

Optical Fibre Categories

Backwards Compatibility

10GBASE-xyz

SFF Connecting Hardware

Testing the New Cabling

Question Time

Close

Symmetric and Asymmetric

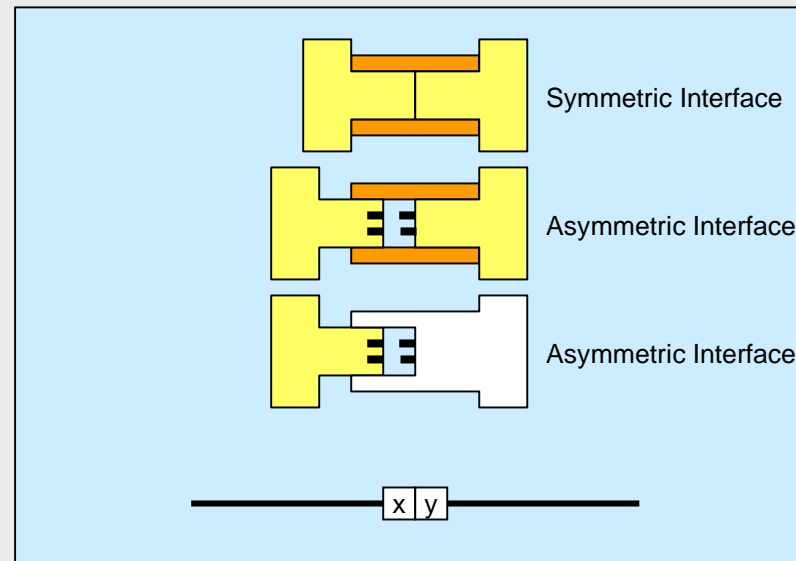

AGENDA

Introduction

A Standards Update

Optical Fibre Categories

Backwards Compatibility

10GBASE-xyz

SFF Connecting Hardware

Testing the New Cabling

Question Time

Close

Testing the New Cabling

Application			Optical Fibre			
			50/125 (OM2)		62.5/125 (OM1)	
Mb/s	Network	λ	Max. length (m)	OPB max. (dB)	Max. length (m)	OPB max. (dB)
4	Token Ring	850 nm	1857 ¹	8.0	2000	13.0
10	Ethernet		1514 ¹	6.8	2000	12.5
16	Token Ring		1857 ¹	8.0	2000	13.0
100	Ethernet	1300 nm	2000	6.0	2000	11.0
1000	Ethernet	850 nm	550	3.56	275	2.6
1000	Ethernet	1300 nm	550	2.35	550	2.35
10000	Ethernet	850 nm	82	1.80	33	1.60
10000	Ethernet	CWDM/850	300	2.46	300	2.46
			50/125 (OM3)			
10000	Ethernet	850 nm	300	2.59		

¹ Calculated values using 1.5dB of connecting hardware losses

AGENDA

- Introduction
- A Standards Update
- Optical Fibre Categories
- Backwards Compatibility
- 10GBASE-xyz
- SFF Connecting Hardware
- Testing the New Cabling
- Question Time
- Close

Link Configurations

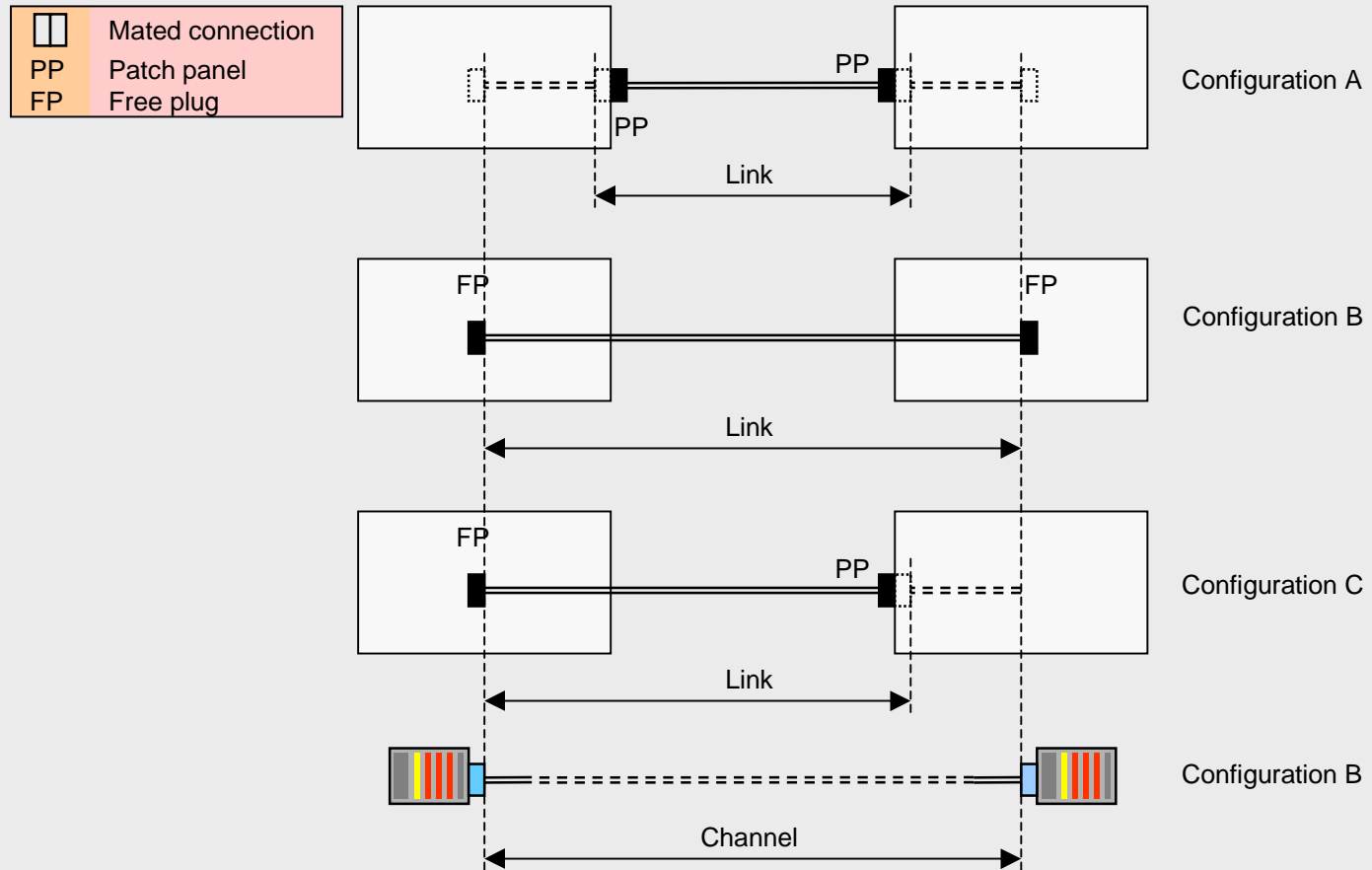

AGENDA

- Introduction
- A Standards Update
- Optical Fibre Categories
- Backwards Compatibility
- 10GBASE-xyz
- SFF Connecting Hardware
- Testing the New Cabling
- Question Time
- Close

Test Systems

EQUIPMENT TYPE	EQUIPMENT TYPE	GENERAL RULES
Uni-directional duplex		Link testing rules Configuration A: OK Configuration B: OK Configuration C: OK Channel tests: OK
Bi-directional duplex		Link testing rules Configuration A: test as channel Configuration B: OK Configuration C: test as channel Channel tests: OK



AGENDA

- Introduction
- A Standards Update
- Optical Fibre Categories
- Backwards Compatibility
- 10GBASE-xyz
- SFF Connecting Hardware
- Testing the New Cabling
- Question Time
- Close

Channel Tests

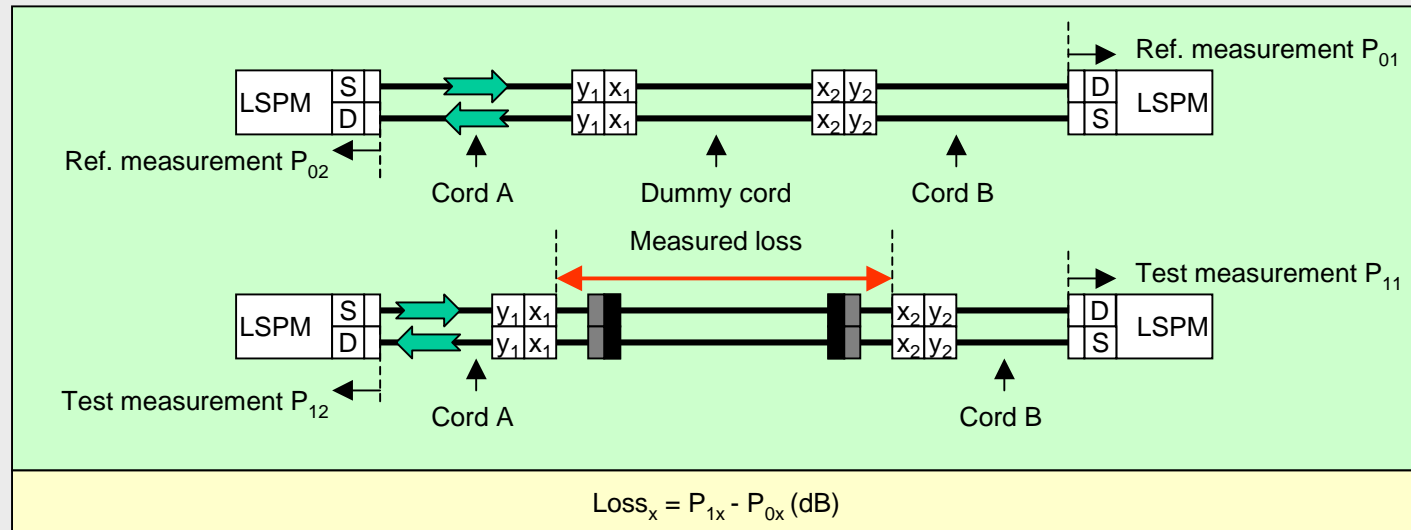

AGENDA

- Introduction
- A Standards Update
- Optical Fibre Categories
- Backwards Compatibility
- 10GBASE-xyz
- SFF Connecting Hardware
- Testing the New Cabling
- Question Time
- Close

Configuration A Links

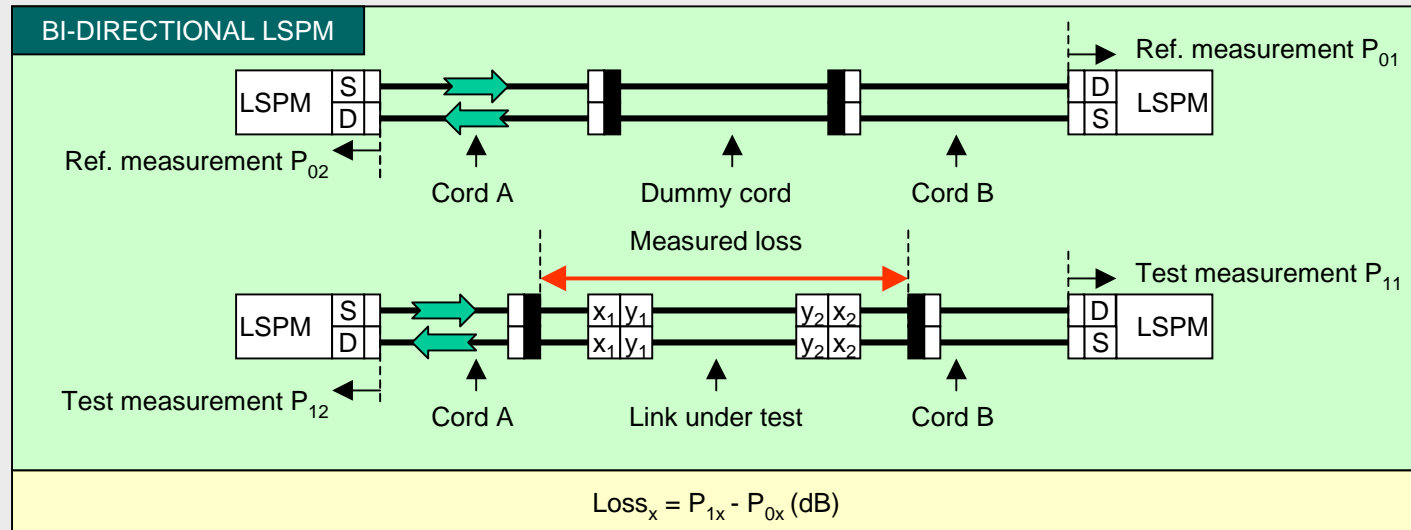

AGENDA

- Introduction
- A Standards Update
- Optical Fibre Categories
- Backwards Compatibility
- 10GBASE-xyz
- SFF Connecting Hardware
- Testing the New Cabling
- Question Time
- Close

Measurement Error

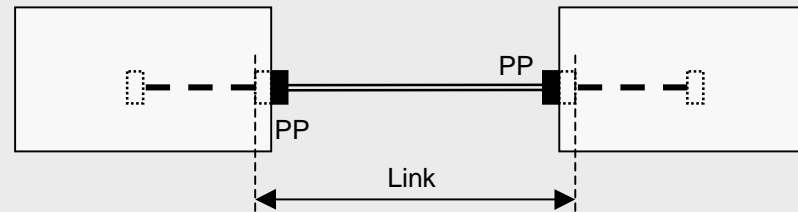

Configuration A

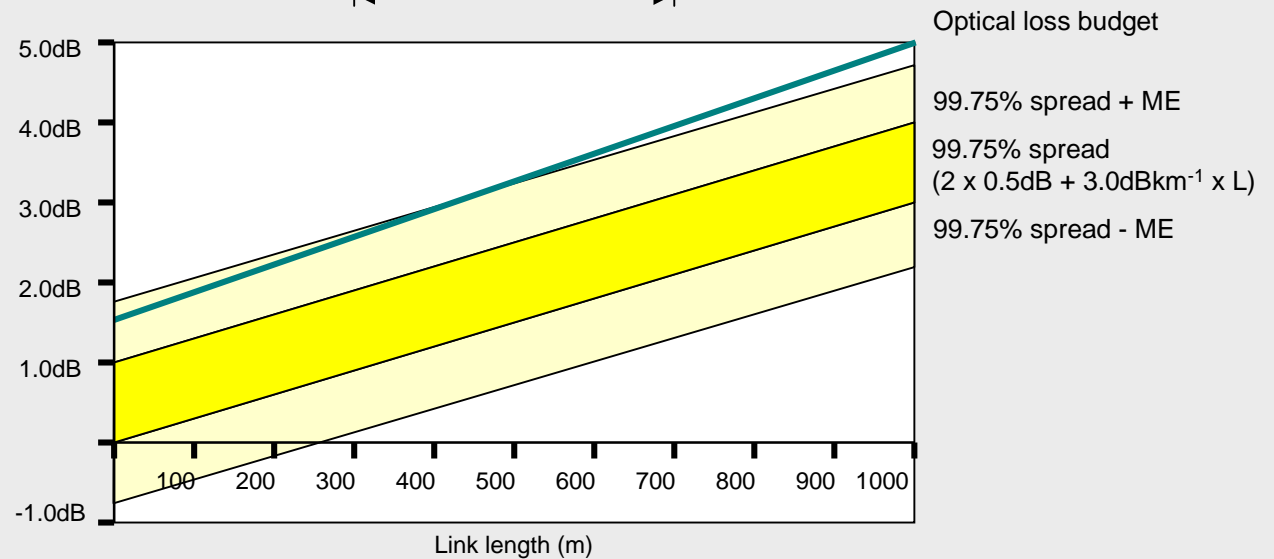

AGENDA

Introduction

A Standards Update

Optical Fibre Categories

Backwards Compatibility

10GBASE-xyz

SFF Connecting Hardware

Testing the New Cabling

Question Time

Close

Test Cords

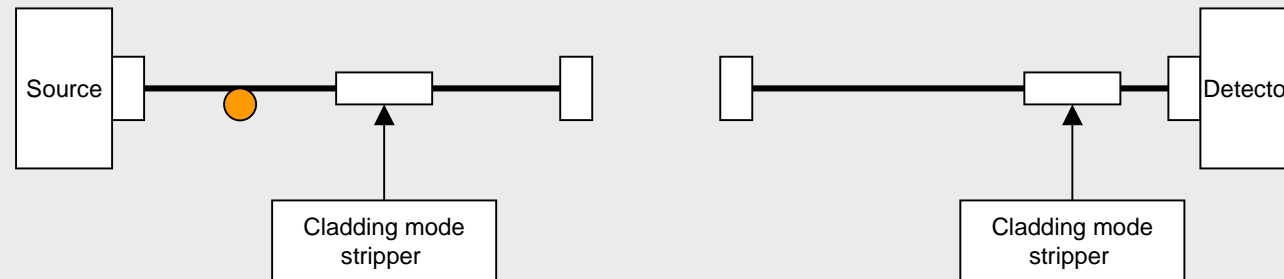

MMF LAUNCH CORD

Mandrel wrap and cladding mode stripper aim to present an equilibrium launch condition

MMF TAIL CORD

Cladding mode stripper provides "core only" light to detector



Removes requirement for bi-directional test

AGENDA

- Introduction
- A Standards Update
- Optical Fibre Categories
- Backwards Compatibility
- 10GBASE-xyz
- SFF Connecting Hardware
- Testing the New Cabling
- Question Time
- Close

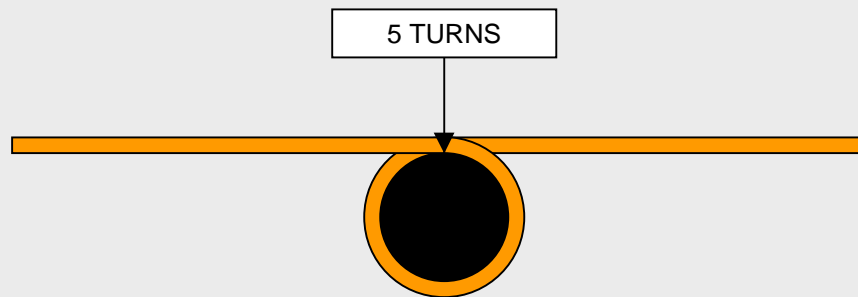
MMF Mandrel Wrap



		
MMF: not applicable	MMF: EN 50346 6MP	MMF: ANSI/TIA/EIA B.1
	50/125 Cable 18	50/125 Cable 25
	50/125 SCOF 15	50/125 SCOF 22
	62.5/125 Cable 20	62.5/125 Cable 20
	62.5/125 SCOF 17	62.5/125 SCOF 17



AGENDA

Introduction

A Standards Update

Optical Fibre Categories

Backwards Compatibility

10GBASE-xyz

SFF Connecting Hardware

Testing the New Cabling

Question Time

Close

LASER LSPM Equipment

There is an argument to suggest that MMF cabling to support LASER-based applications should be tested with LASER sources

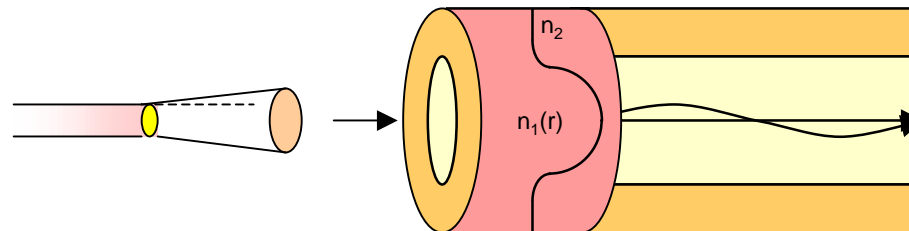

Reference measurement does not contain all modes.

Test measurement reads LOW.

Test results can vary with test lead handling.

Unless explicitly allowed and documented such equipment should not be used

AGENDA

Introduction

A Standards Update

Optical Fibre Categories

Backwards Compatibility

10GBASE-xyz

SFF Connecting Hardware

Testing the New Cabling

Question Time

Close

OTDR vs. LSPM

SHORT LENGTH SYNDROME
calls LSPM measurements into question

(unless measurement error is "allowed for" in adjudication)

OTDRs can be used to assess and measure individual components
(subject to appropriate techniques)

COMPONENT UP VERIFICATION MAY BECOME MORE COMMON

AGENDA

Introduction

A Standards Update

Optical Fibre Categories

Backwards Compatibility

10GBASE-xyz

SFF Connecting Hardware

Testing the New Cabling

Question Time

Close

FIA Documentation Update

DESIGN		
FIA-TSD-2000-1-1	OPTICAL FIBRE CABLING: LAN APPLICATION SUPPORT GUIDE	JANUARY 2001
	Revision to include mode conditioning cords and 10GBASE-xyz	JANUARY 2002
INSTALLATION		
FIA-TSD-2000-4-2-1	TESTING OF INSTALLED CABLING: ATTENUATION USING LSPM EQUIPMENT	JANUARY 2002
FIA-TSD-2000-4-2-2	TESTING OF INSTALLED CABLING: ATTENUATION USING OTDR EQUIPMENT	mid 2002
SAFETY		
FIA-TSD-2000-5-1	OPTICAL POWER: SAFETY LEVELS	DECEMBER 2001
FIA-TSD-2000-5-2	OPTICAL FIBRE: HANDLING OF PROCESSING CHEMICALS	
FIA-TSD-2000-5-3	OPTICAL FIBRE: DISPOSAL OF WASTE	

MODELLING TOOLS	
CABLING STRUCTURES COST MODEL	DECEMBER 2001

AGENDA

Introduction

A Standards Update

Optical Fibre Categories

Backwards Compatibility

10GBASE-xyz

SFF Connecting Hardware

Testing the New Cabling

Question Time

Close

Question Time

FIA

The Fibreoptic Industry Association



The New Generation of Optical Fibre Components

Prepared and delivered for



Edinburgh Hilton
11th October 2001