

Infrastructure Administration - STANDARDS AND PRACTICES



SIG/2/1 and SIG/2/2
9th March 2004

Updated
"Mind the Gap"
Seminar
1st December 1st 1999
www.it-cabling.com/tcpservices/kb01-01a.htm

Mike Gilmore

AGENDA

Opening Remarks

Introduction to
Installation Standards
(pre-2004)

Generic Cabling

BS 6701:2004

Close



Mike Gilmore
Senior Partner,
The Cabling Partnership

Managing Director
e-Ready Building

Standards Activities



Member:
ISO/IEC JTC1 SC25 WG3: Generic Cabling
ISO/IEC JTC1 SC25 Project Team: SOHO

Convenor:
ISO/IEC JTC1 SC25 WG3 IPTG: Industrial Premises Cabling



Convenor:
CENELEC TC215 WG1: IT Cabling
CENELEC TC215 WG1 PT Industrial Premises Cabling
Secretary:
CENELEC TC215 WG1 PT Data Centre Cabling



**BSI TCT7: Telecommunications -
Installation Requirements**
Chairman:
BSI TCT7/-1: Cabling: Infrastructure design, planning and commissioning
BSI TCT7/-3: Cabling: Infrastructure standards - UK implementation panel

Technical and Standards Director: Fibreoptic Industry Association

e-mail: mike.gilmore@btinternet.com

Mobile: +44 (0) 7860 110563

BS 7718:1996

AGENDA

Opening Remarks

Introduction to
Installation Standards
(pre-2004)

Generic Cabling

BS 6701:2004

Close

OPTICAL FIBRE



BS 7718

Code of Practice for the installation of fibre optic cabling

DEVELOPED BY	BSI ECL/22 WG3
INTERIM PUBLICATION	FIA as FIA-CCP/1/91: 1991
BS PUBLICATION	BS 7718: 1995
AMENDED	BS 7718 A.1: 1996

Only applicable if called up in
contract documentation

BS 6701:1994

AGENDA

Opening Remarks

Introduction to
Installation Standards
(pre-2004)

Generic Cabling

BS 6701:2004

Close

TELECOMMUNICATIONS CABLING



BS 6701

Code of Practice for the installation of apparatus intended for connection to certain telecommunications systems

DEVELOPED BY	BSI TCT/7
PUBLICATION	BS 6701-1 and -2: 1986
REVISED	BS 6701-1 and -2: 1990
REVISED	BS 6701: 1994
AMENDED	BS 6701 A.1: 1997
AMENDED	BS 6701 A.1 and A.2: 1999

Referenced from BS 7671 re- segregation
A basis for Pre-Connection Inspection
"certification"

AGENDA

Opening Remarks

Introduction to Installation Standards (pre-2004)



Generic Cabling

BS 6701:2004

Close

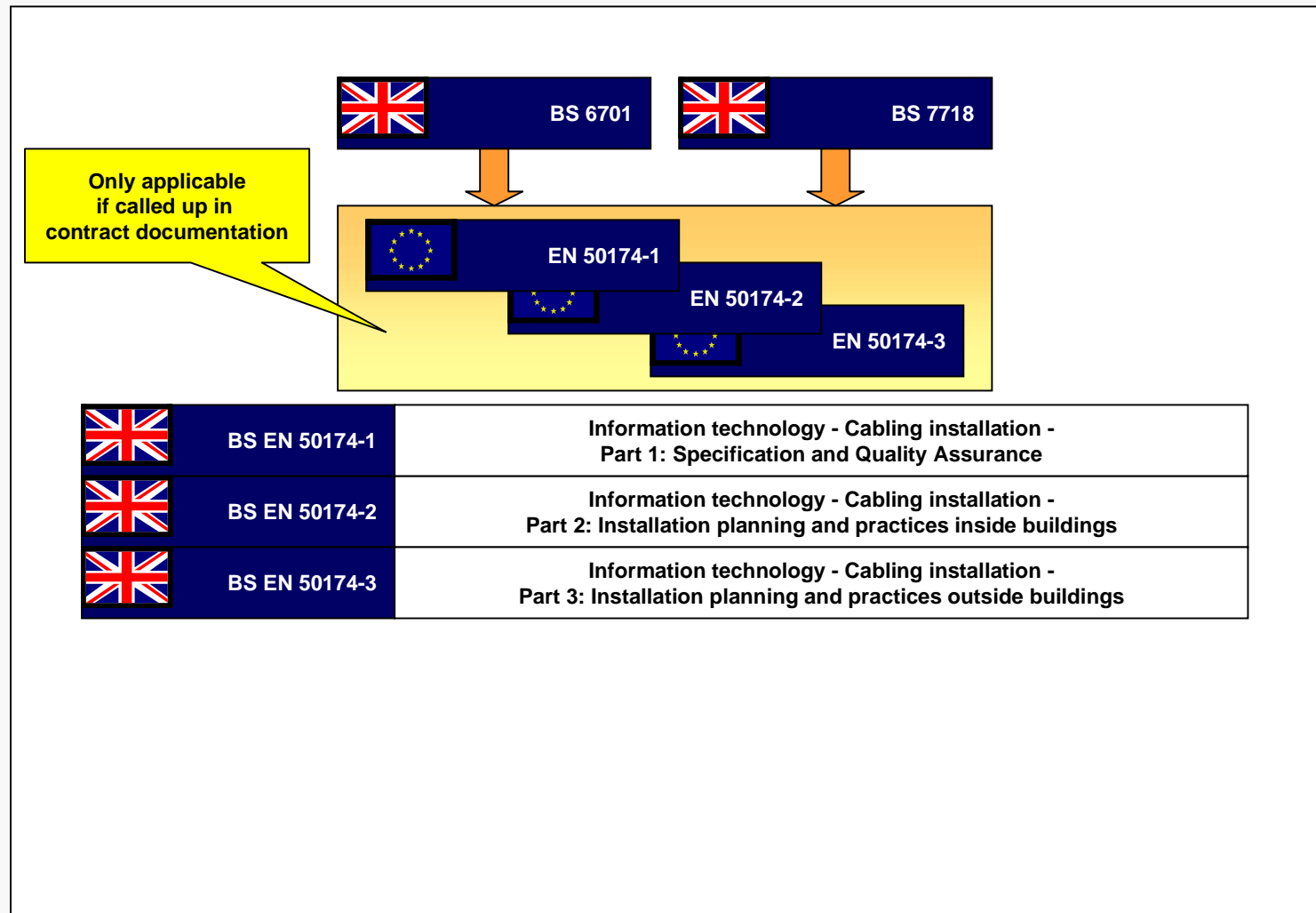
BS EN 50174-X Standards



	BS EN 50174-1	Information technology - Cabling installation - Part 1: Specification and Quality Assurance
	BS EN 50174-2	Information technology - Cabling installation - Part 2: Installation planning and practices inside buildings
	BS EN 50174-3	Information technology - Cabling installation - Part 3: Installation planning and practices outside buildings

Generic Cabling

AGENDA

Opening Remarks

Introduction to
Installation Standards
(pre-2004)

Generic Cabling

BS 6701:2004

Close

GENERIC CABLING



BS EN 50173-1

Information technology - Generic cabling systems -
General requirements and office areas



ISO/IEC 11801
(2002)

Information technology - Generic cabling for customer premises



TIA/EIA-568-B
series

Commercial Building Telecommunications Cabling Standard

Channel Construction

AGENDA

Opening Remarks

Introduction to Installation Standards (pre-2004)

Generic Cabling

BS 6701:2004

Close

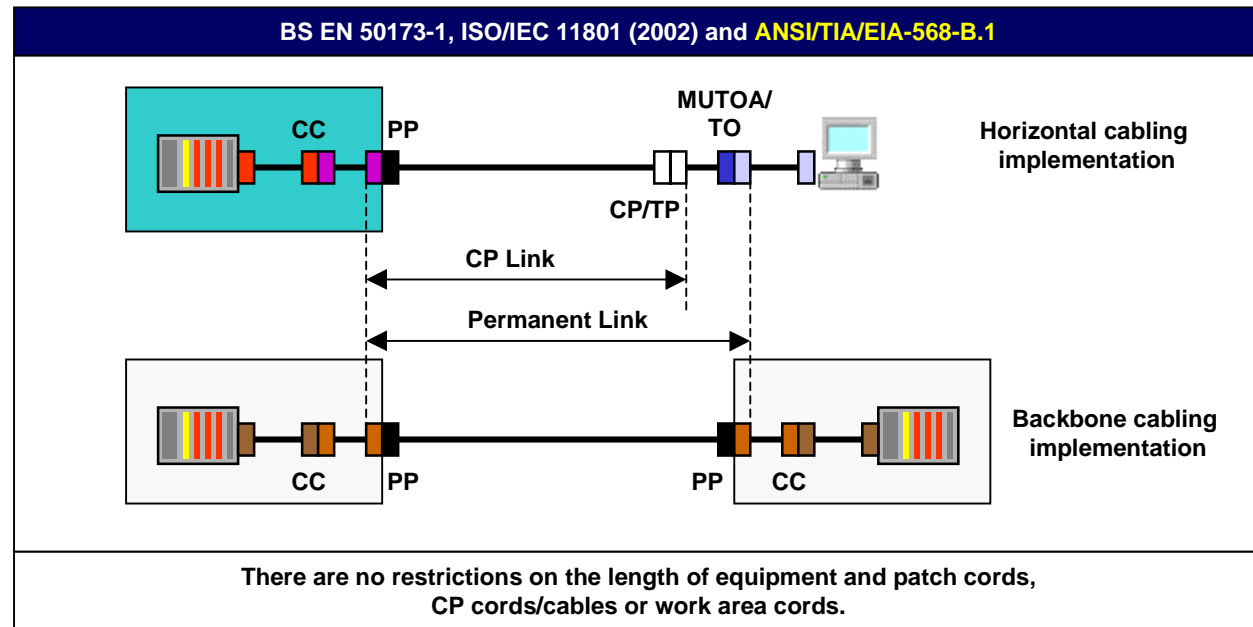
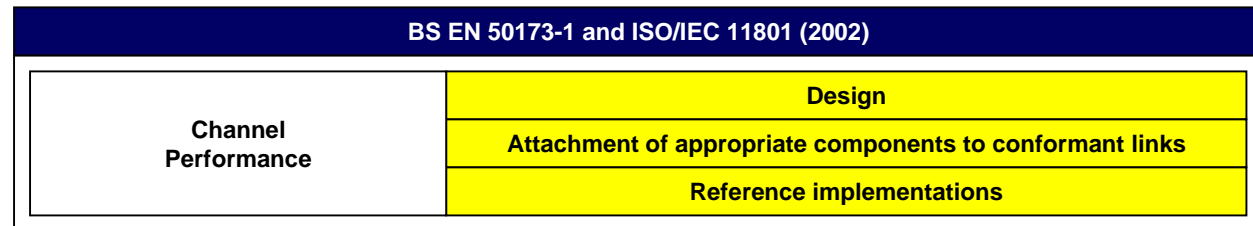

Available Margin or Length-Dependency

AGENDA

Opening Remarks

Introduction to Installation Standards (pre-2004)

Generic Cabling

BS 6701:2004

Close

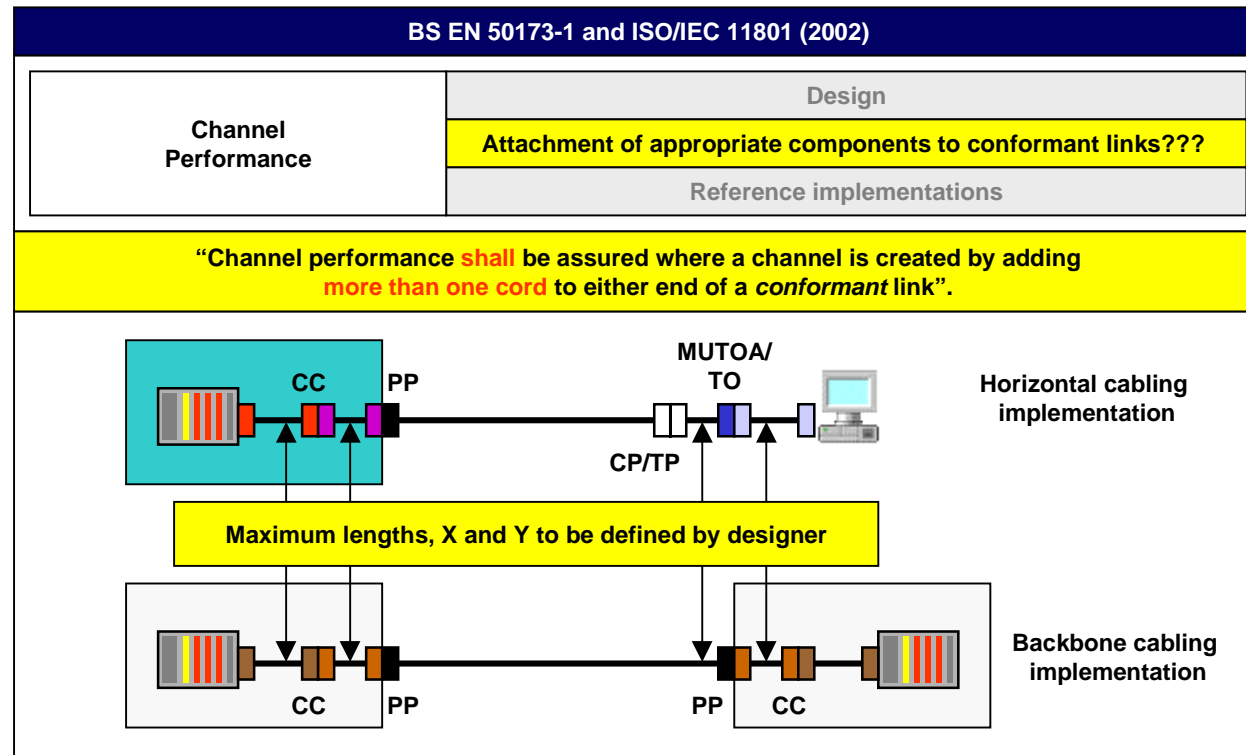

AGENDA

Opening Remarks

Introduction to
Installation Standards
(pre-2004)

Generic Cabling

BS 6701:2004

Close

Length-Dependent Limits

ISO/IEC 11801 (2002) and (BS) EN 50173-1

Class	Frequency	Maximum link insertion loss (dB)
D	$1 \leq f \leq 100$	$(L/100) * (1,9108 * \sqrt{f} + 0,0222 * f + 0,2 / \sqrt{f}) + n * 0,04 * \sqrt{f}$, 4dB min.
E	$1 \leq f \leq 250$	$(L/100) * (1,82 * \sqrt{f} + 0,0169 * f + 0,25 / \sqrt{f}) + n * 0,02 * \sqrt{f}$, 4dB min.
F	$1 \leq f \leq 600$	$(L/100) * (1,80 * \sqrt{f} + 0,010 * f + 0,2 / \sqrt{f}) + n * 0,02 * \sqrt{f}$, 4dB min.
Class	Frequency	Max. link loop resistance (Ω)
D E F	d.c	$(L/100) * 22 + n * 0,4$
<p>n = number of connections within the link and Y = attenuation premium for the CP cable/cord $L(m) = L_{FC} + L_{CP} * Y$ where L_{FC} = length of fixed cable and L_{CP} = length of CP cord</p>		
Class	Max. link propagation delay (μs)	
D E F	$(L/100) * (0,534 + 0,036 / \sqrt{f}) + n * 0,0025$	
Class	Max. link delay skew (μs)	
D E F	$(L/100) * 0,025 + n * 0,00125$	
<p>n = number of connections within the link, $L(m) = L_{FC} + L_{CP}$ where L_{FC} = length of fixed cable, L_{CP} = length of CP cord.</p>		

Reference Implementations

AGENDA

Opening Remarks

Introduction to
Installation Standards
(pre-2004)

Generic Cabling

BS 6701:2004

Close

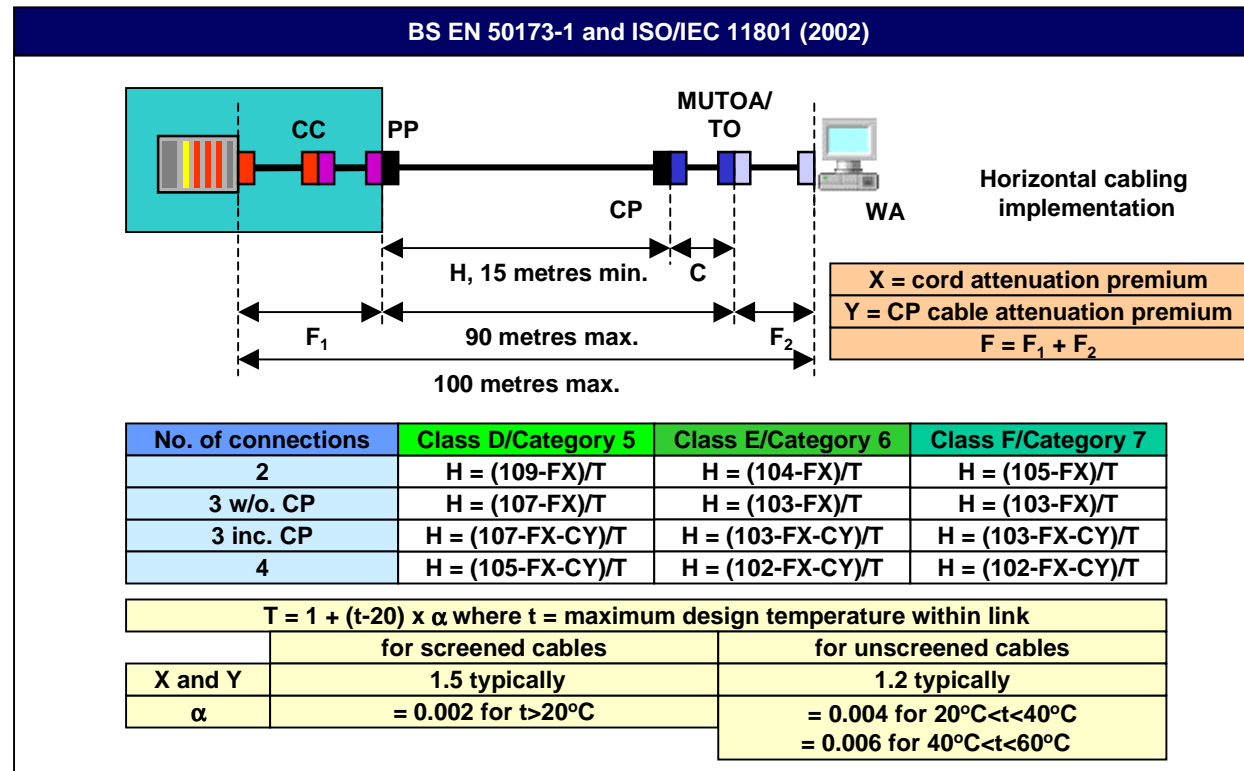

“using the reference implementations of clause ... and compatible cabling components conforming to the requirements of clauses ..., ... and ..., based upon a statistical approach of performance modelling.”

AGENDA

Opening Remarks

Introduction to
Installation Standards
(pre-2004)

Generic Cabling

BS 6701:2004

Close

Cords

Cross-over cord (looks straight-through)

Straight-through cord (looks crossed)

BALANCED

IN GENERAL

- multi-vendor connections
 - interoperability cannot be assumed;
 - not guaranteed by BS EN or IEC specifications
- cords are subject to length rules dependent upon:
 - performance;
 - location;
 - **environment**;
- equipment cords may be subject to polarity rules
- network failure can result:
 - if length rules are breached;
 - if polarity is not maintained;
 - if cords are badly installed and managed.

MMF OPTICAL FIBRE

IN GENERAL

- multi-vendor connections
 - interoperability cannot be assumed;
 - not guaranteed by IEC specifications
 - **except for SC and SC-D**
- cords are subject to length rules dependent upon:
 - performance;
 - location;
- equipment cords may be subject to polarity rules
- network failure can result:
 - if polarity is not maintained
 - if bandwidth is impacted.

Cord Administration

AGENDA

Opening Remarks

Introduction to
Installation Standards
(pre-2004)

Generic Cabling

BS 6701:2004

Close

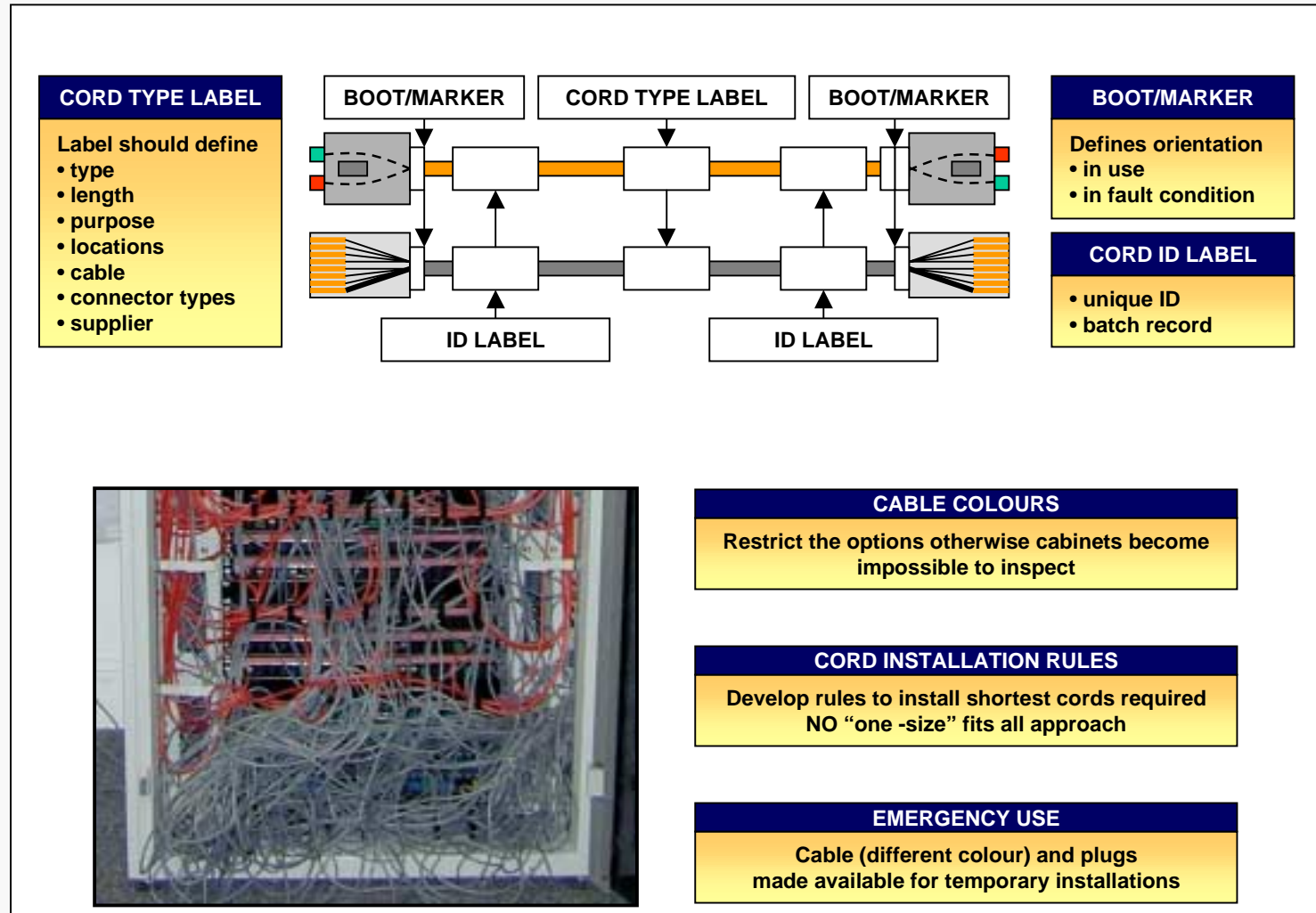

CORD TYPE LABEL

Label should define

- type
- length
- purpose
- locations
- cable
- connector types
- supplier

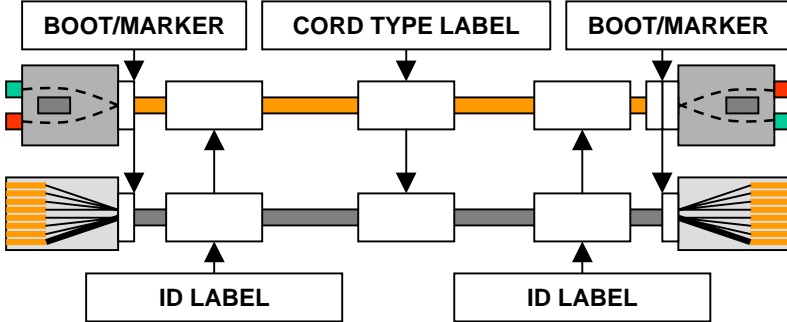

BOOT/MARKER

Defines orientation

- in use
- in fault condition

CORD ID LABEL

- unique ID
- batch record

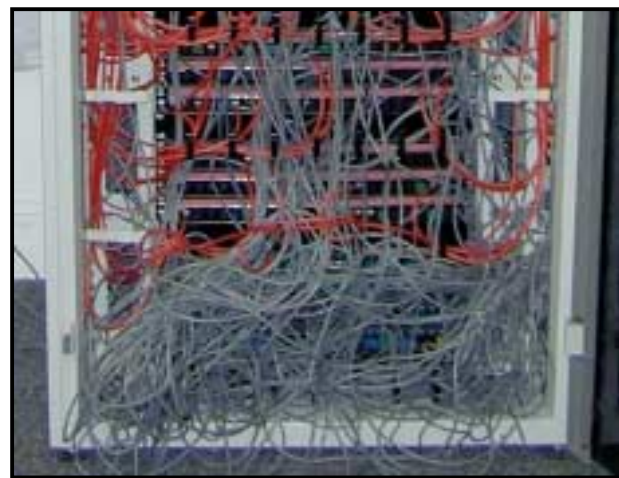

CABLE COLOURS

Restrict the options otherwise cabinets become impossible to inspect

CORD INSTALLATION RULES

Develop rules to install shortest cords required
NO "one-size" fits all approach

EMERGENCY USE

Cable (different colour) and plugs made available for temporary installations

Administration in BS EN 50174-1

AGENDA

Opening Remarks

Introduction to
Installation Standards
(pre-2004)

Generic Cabling

BS 6701:2004

Close

INSTALLER'S RESPONSIBILITIES

PREMISES OWNER'S RESPONSIBILITIES



BS EN 50174-1

Information technology - Cabling installation -
Part 1: Specification and Quality Assurance

[4.1] requires that administration be considered early in the specification process.
[7.1] if administration systems are used, requires that consideration be given to specific aspects undertaken:

- compatibility with the cabling system;
- compatibility with installation documentation.

[7.2] contains requirements for identifiers if used.
[7.4.1] contains requirements for reports, if used.
[7.4.2] contains requirements for drawings, if used.

AGENDA

Opening Remarks

Introduction to
Installation Standards
(pre-2004)

Generic Cabling

BS 6701:2004

Close

Déjà Vu

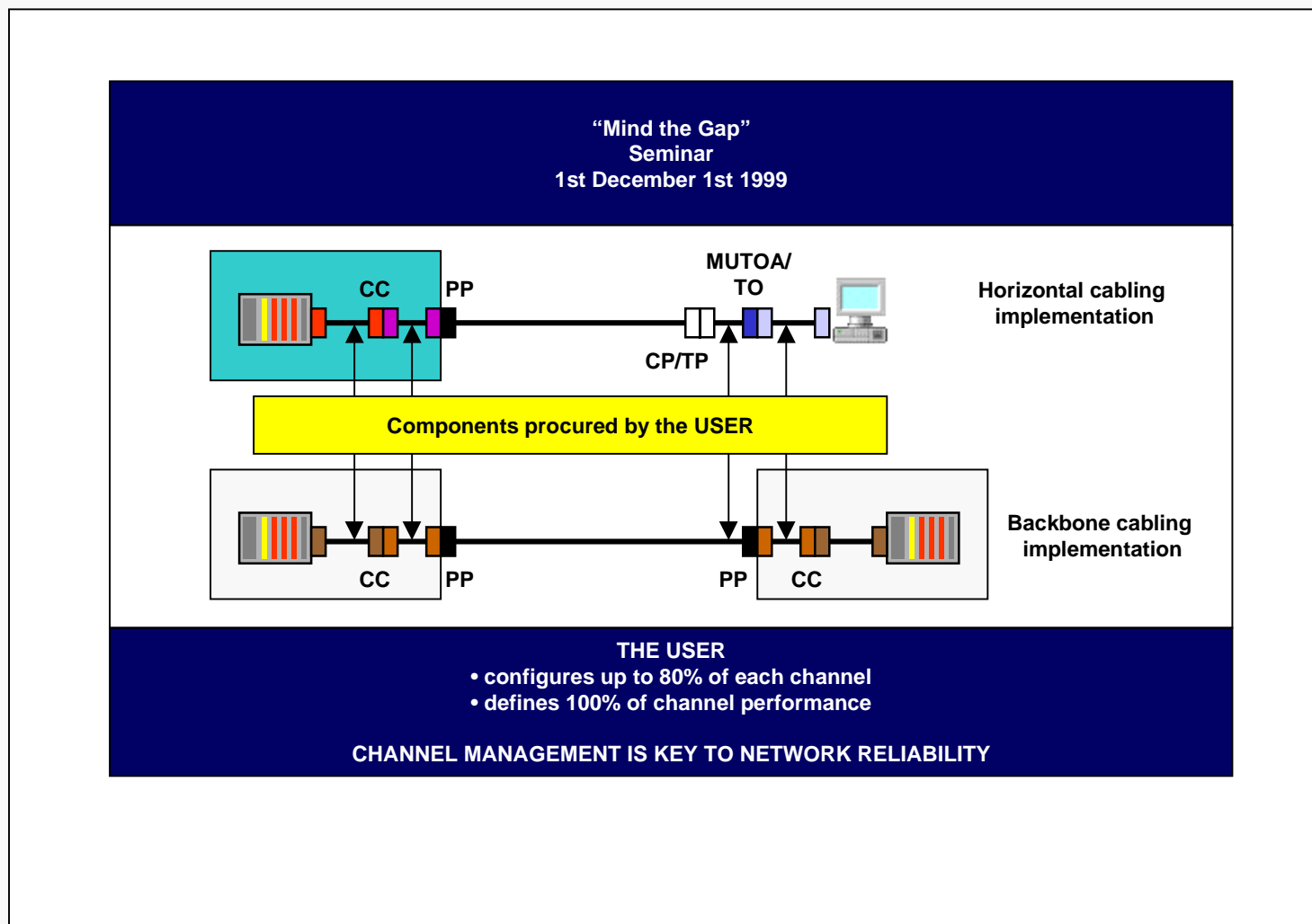

The Impact of BS EN 50174-X Standards

AGENDA

Opening Remarks



Introduction to Installation Standards (pre-2004)

Generic Cabling

BS 6701:2004

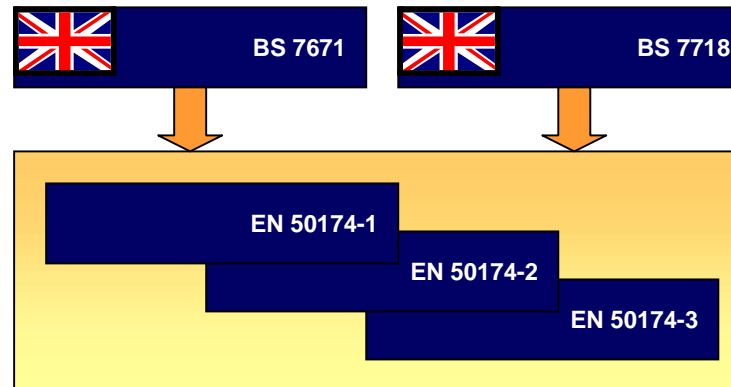
Close



	BS EN 50174-1	Information technology - Cabling installation- Part 1: Specification and Quality Assurance
	BS EN 50174-2	Information technology - Cabling installation- Part 2: Installation planning and practices inside buildings
	BS EN 50174-3	Information technology - Cabling installation- Part 3: Installation planning and practices outside buildings



AGENDA

- Opening Remarks
- Introduction to Installation Standards (pre-2004)
- Generic Cabling
- BS 6701:2004
- Close

The Overall Plan

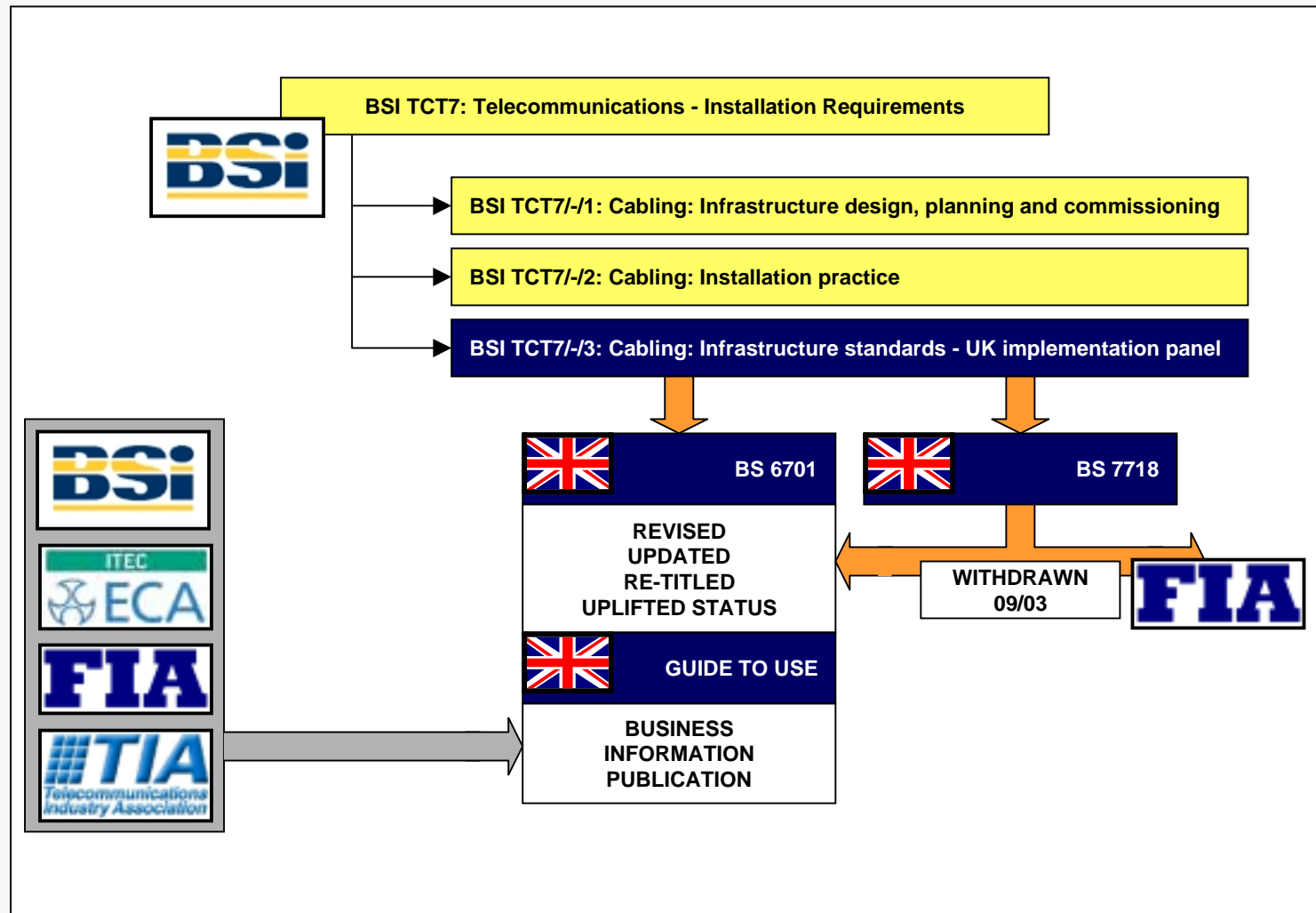

AGENDA

Opening Remarks

Introduction to
Installation Standards
(pre-2004)

Generic Cabling

BS 6701:2004

Close

BS 6701:2004

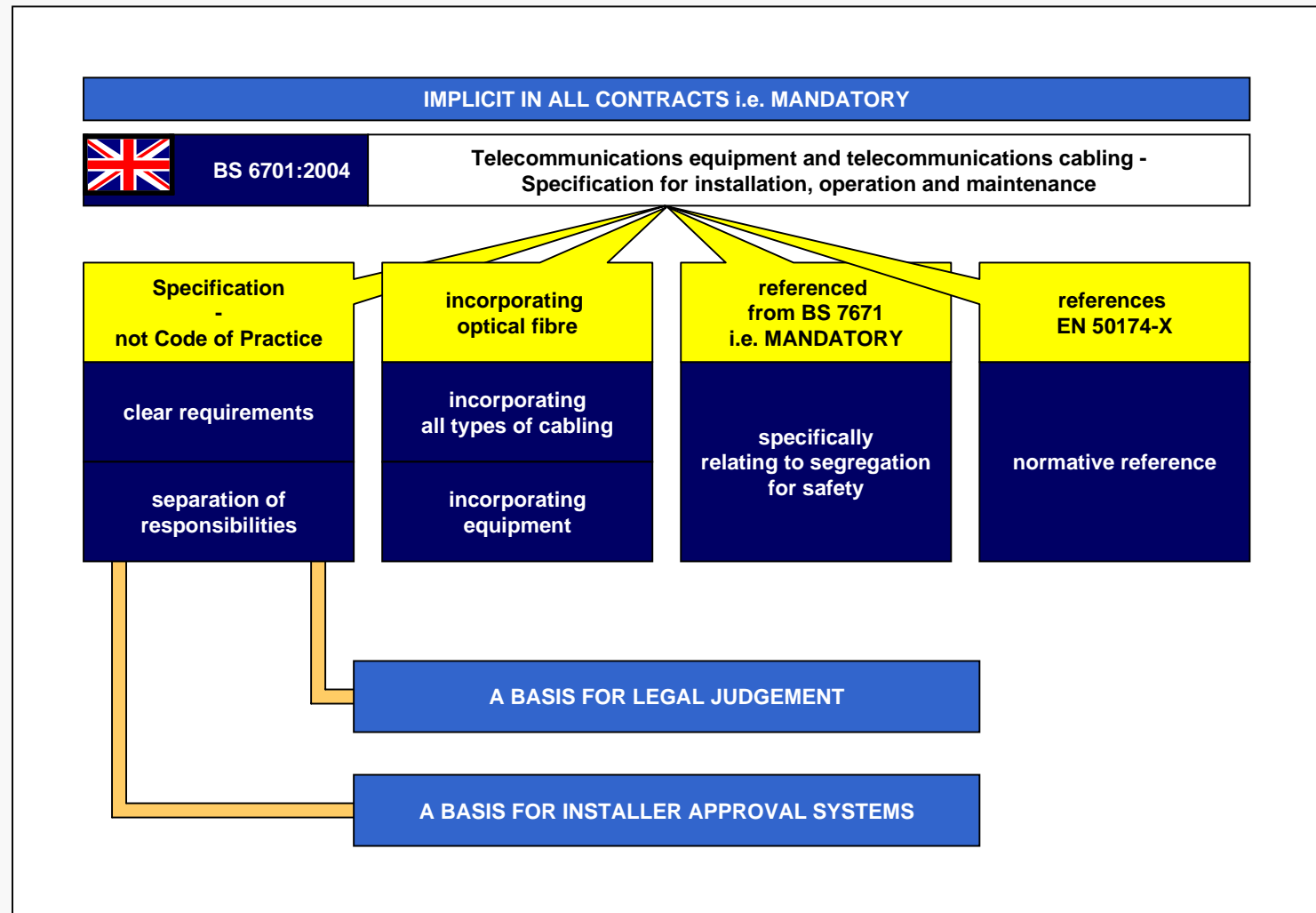

Installation Safety

AGENDA

Opening Remarks

Introduction to
Installation Standards
(pre-2004)

Generic Cabling

BS 6701:2004

Close

TELECOMMUNICATIONS CABLING



BS 6701



BS 7671

Requirements for electrical installations:
IEE Wiring Regulations: 16th edition

UK SAFETY STANDARD
Instrument of the Electricity at Work Act 1989

OPTICAL FIBRE



BS 7718



BS EN 60825-2

Safety of Laser Products - Part 2: Safety of optical fibre communication systems

UK publication of
INTERNATIONAL SAFETY STANDARD

Operational Responsibility

AGENDA

Opening Remarks

Introduction to
Installation Standards
(pre-2004)

Generic Cabling

BS 6701:2004

Close

INSTALLER'S RESPONSIBILITIES

PREMISES OWNER'S RESPONSIBILITIES



BS 6701:2004

**Telecommunications equipment and telecommunications cabling -
Specification for installation, operation and maintenance**

Installation, operating and maintenance instructions for all telecommunications equipment and telecommunications cabling shall be obtained.

All relevant documentation shall be provided to enable the owner of the premises to implement operating procedures for the telecommunications system(s).

Final acceptance, as defined in the quality plan shall only proceed following marking, labelling and fitting of all components associated with the telecommunications cabling.

Complete and accurate records relating to telecommunications equipment and telecommunications cabling shall be maintained.

Telecommunications equipment and telecommunications cabling shall be operated in accordance with the instructions provided by the installer.

The selection and operation of optical fibre telecommunications equipment, test equipment and optical fibre telecommunications cabling shall be in accordance with BS EN 60825-2.

The telecommunications equipment and telecommunications cabling shall be maintained in accordance with the instructions provided by the installer.

All relevant personnel shall be made aware of all policies required to maintain proper operation of the telecommunications system.

Independent of the configuration of installed telecommunications equipment and telecommunications cabling, there shall be a documented policy in the event of faults and breakdowns.

AGENDA

Opening Remarks

**Introduction to
Installation Standards
(pre-2004)**

Generic Cabling

BS 6701:2004

Close

Close