



“MIND THE GAP” - A guide to the management of cabling performance

prepared and delivered

by



BSI,
Chiswick, London
1st December 1999

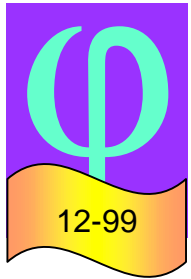

Mike Gilmore

Senior Partner, The Cabling Partnership

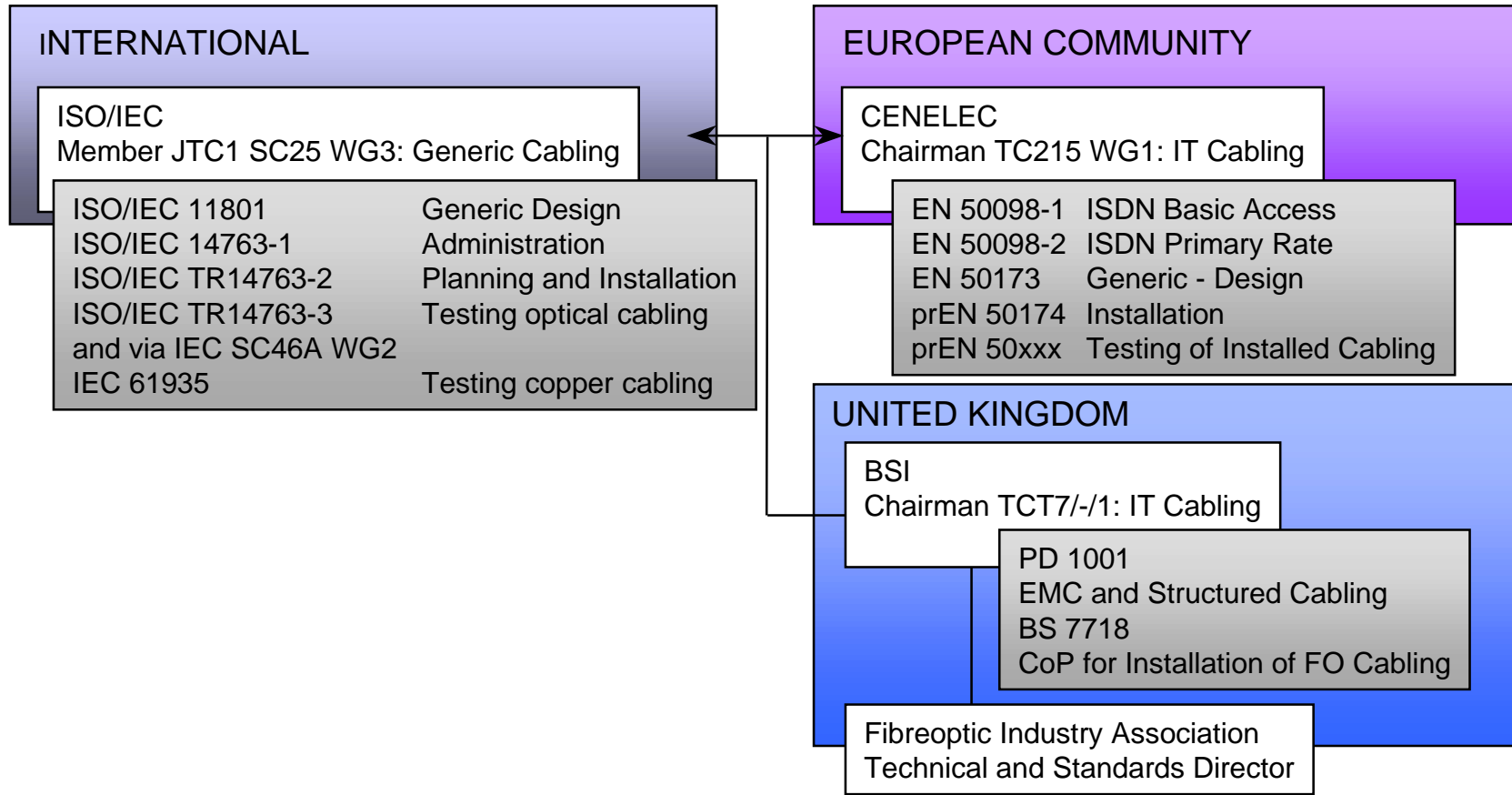

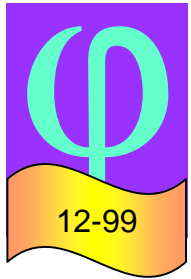

"MIND THE GAP" - A GUIDE TO THE MANAGEMENT OF CABLING PERFORMANCE

Agenda

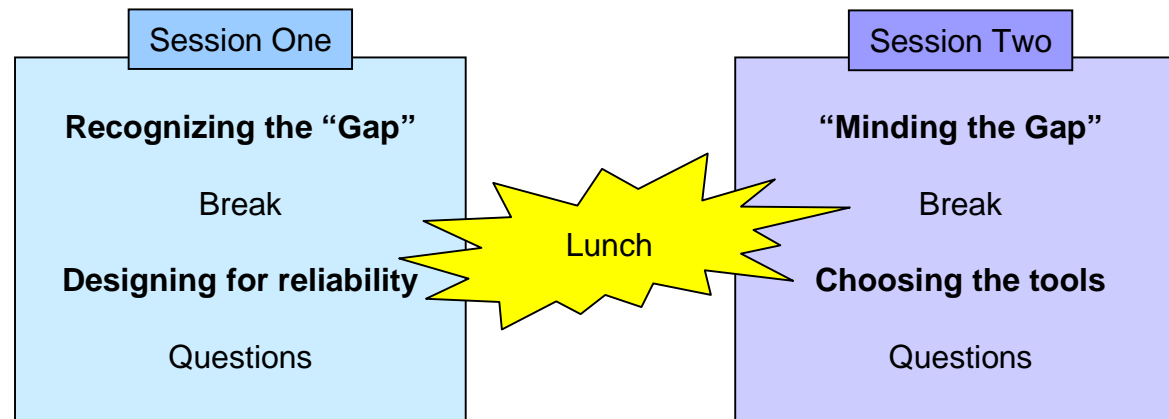

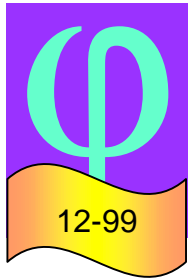

"MIND THE GAP" - A GUIDE TO THE MANAGEMENT OF CABLING PERFORMANCE

Agenda

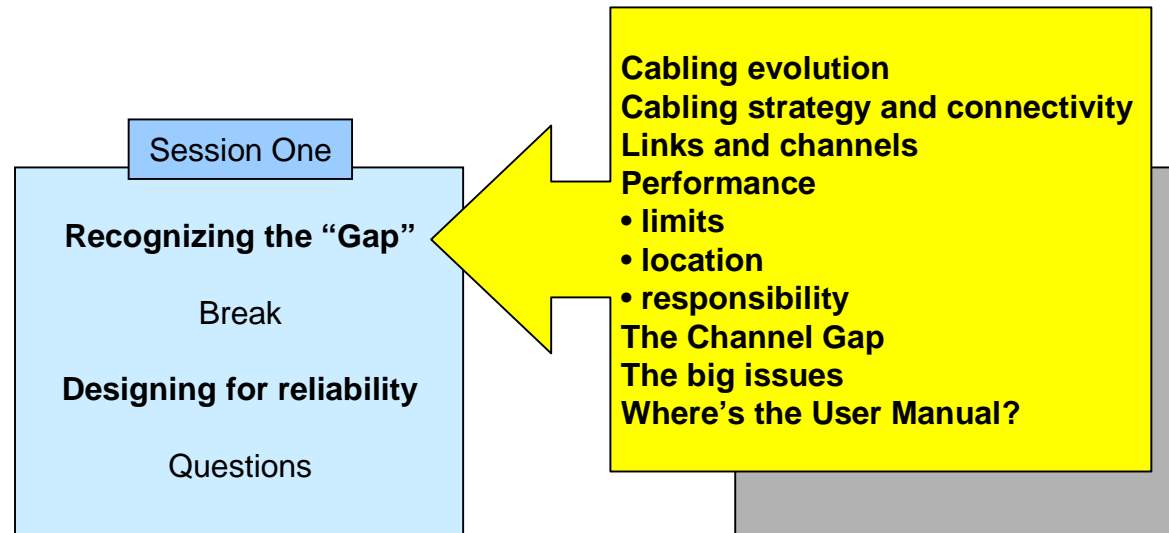

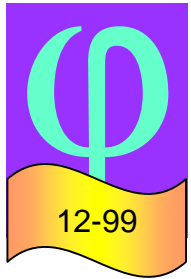

"MIND THE GAP" - A GUIDE TO THE MANAGEMENT OF CABLING PERFORMANCE

Cabling evolution

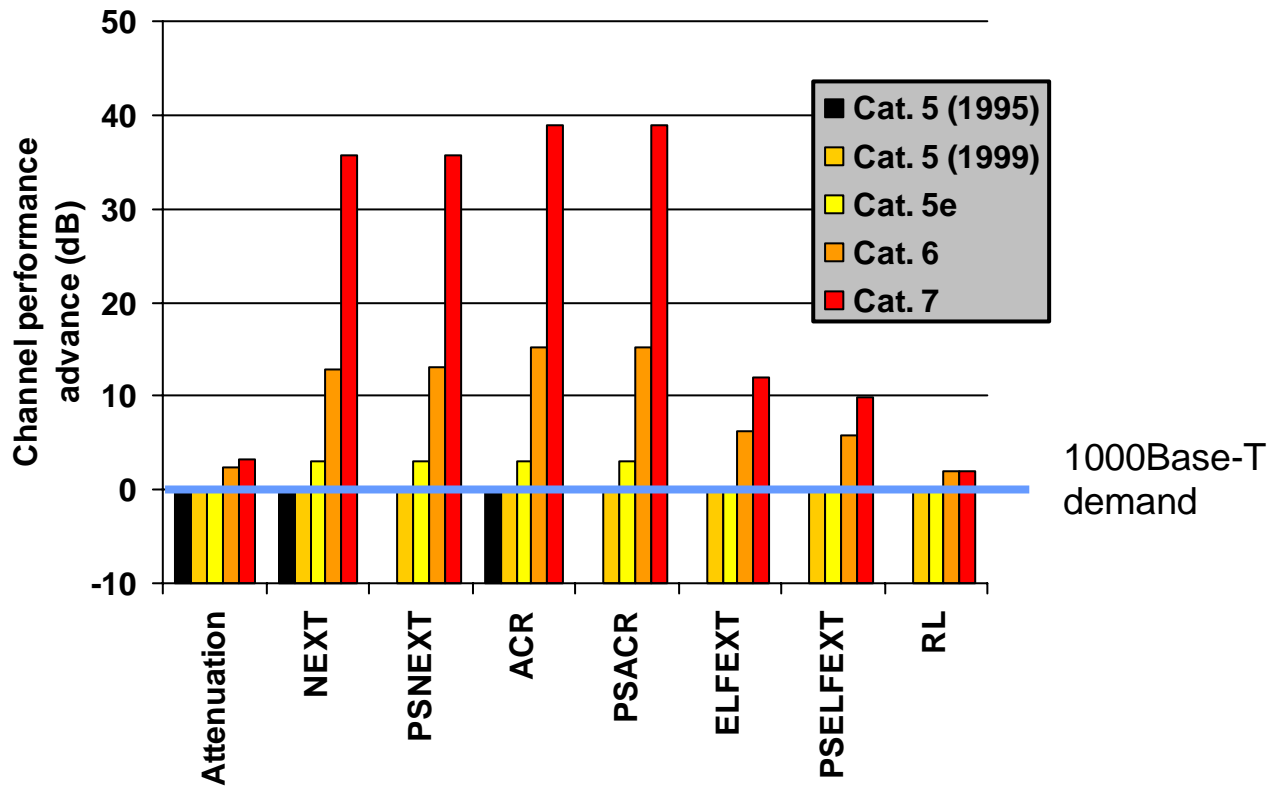

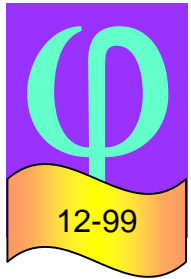

"MIND THE GAP" - A GUIDE TO THE MANAGEMENT OF CABLING PERFORMANCE

Gigabit network implementation

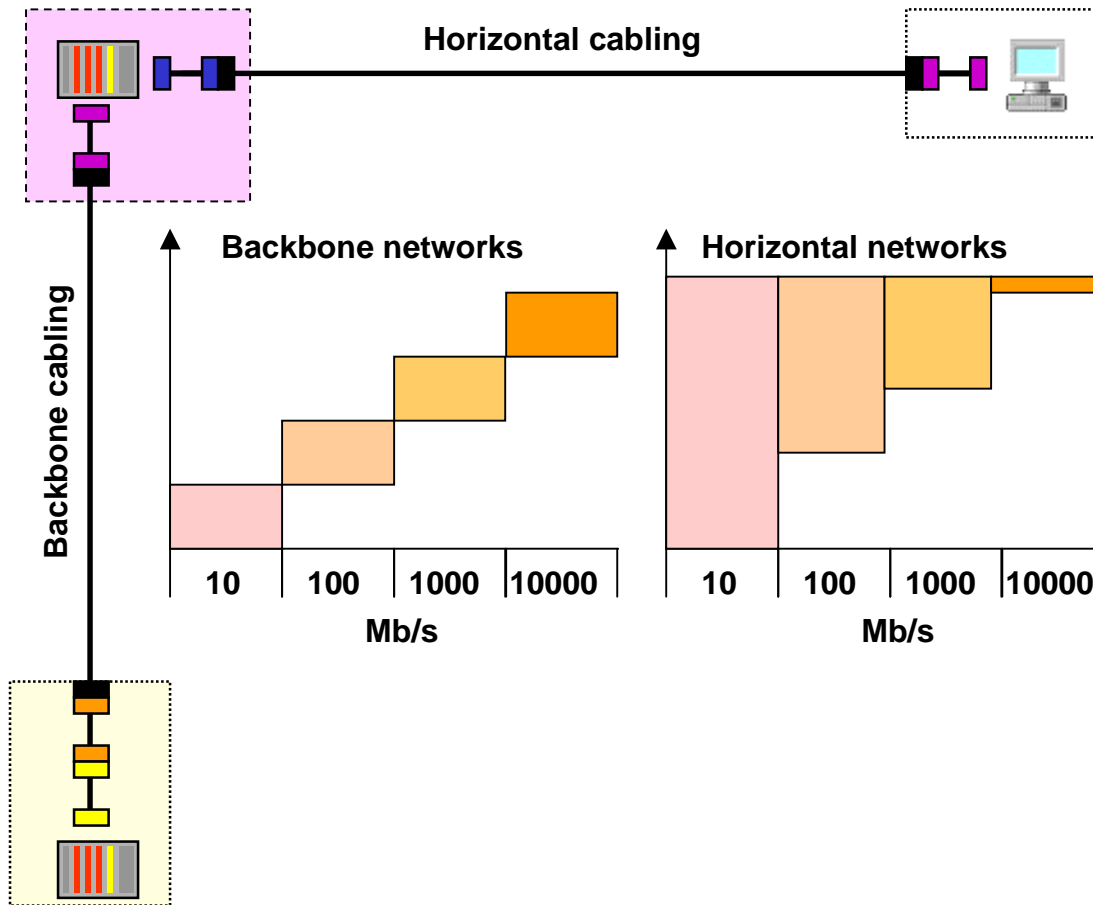

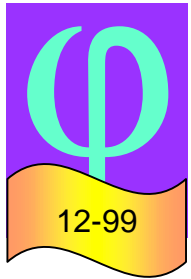

"MIND THE GAP" - A GUIDE TO THE MANAGEMENT OF CABLING PERFORMANCE

Cabling design strategy - I

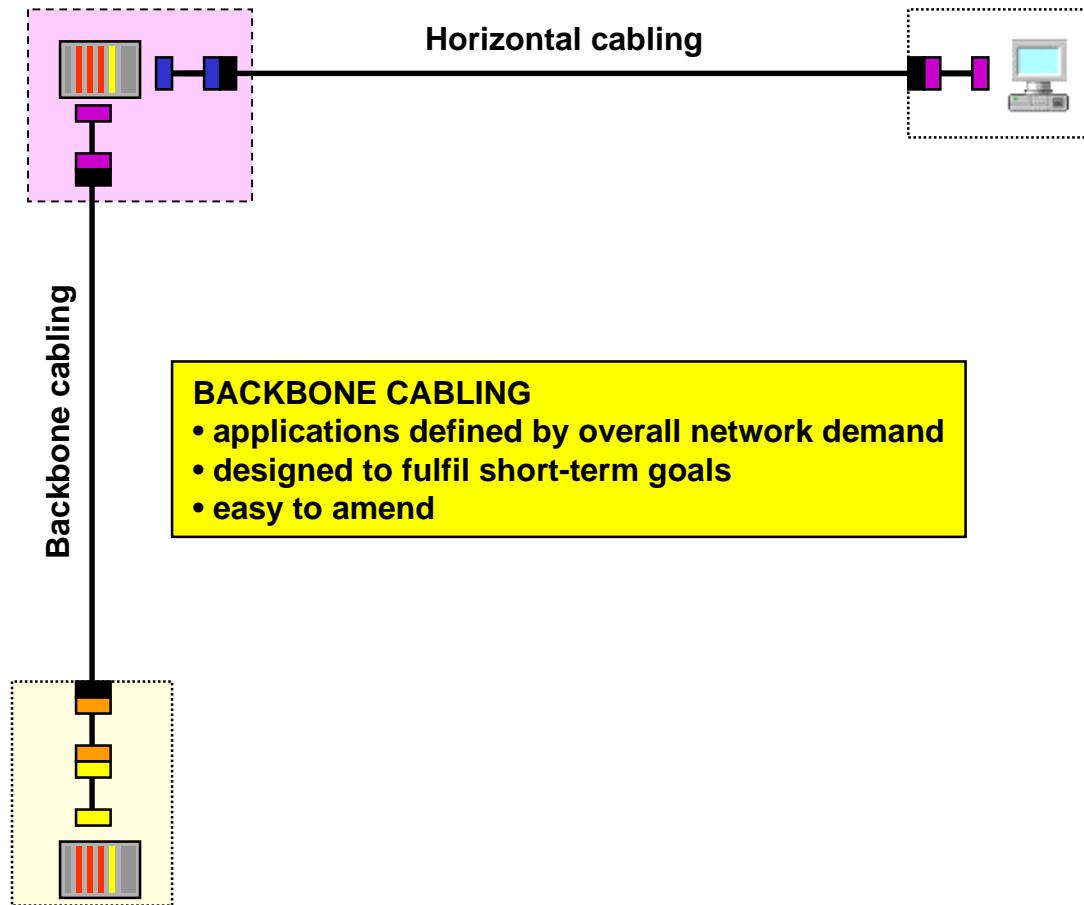

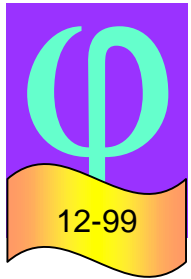

“MIND THE GAP” - A GUIDE TO THE MANAGEMENT OF CABLING PERFORMANCE

Cabling design strategy - II

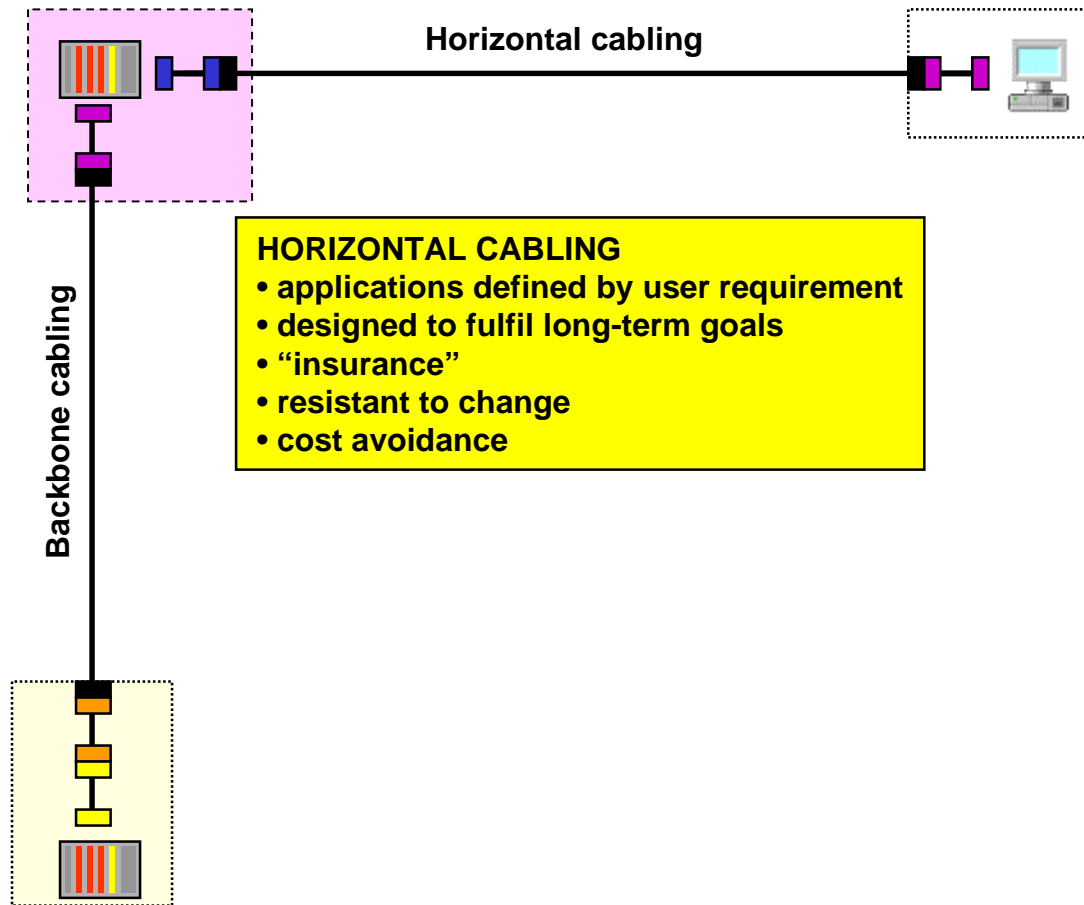

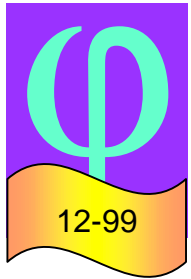

“MIND THE GAP” - A GUIDE TO THE MANAGEMENT OF CABLING PERFORMANCE

Copper cabling connectivity

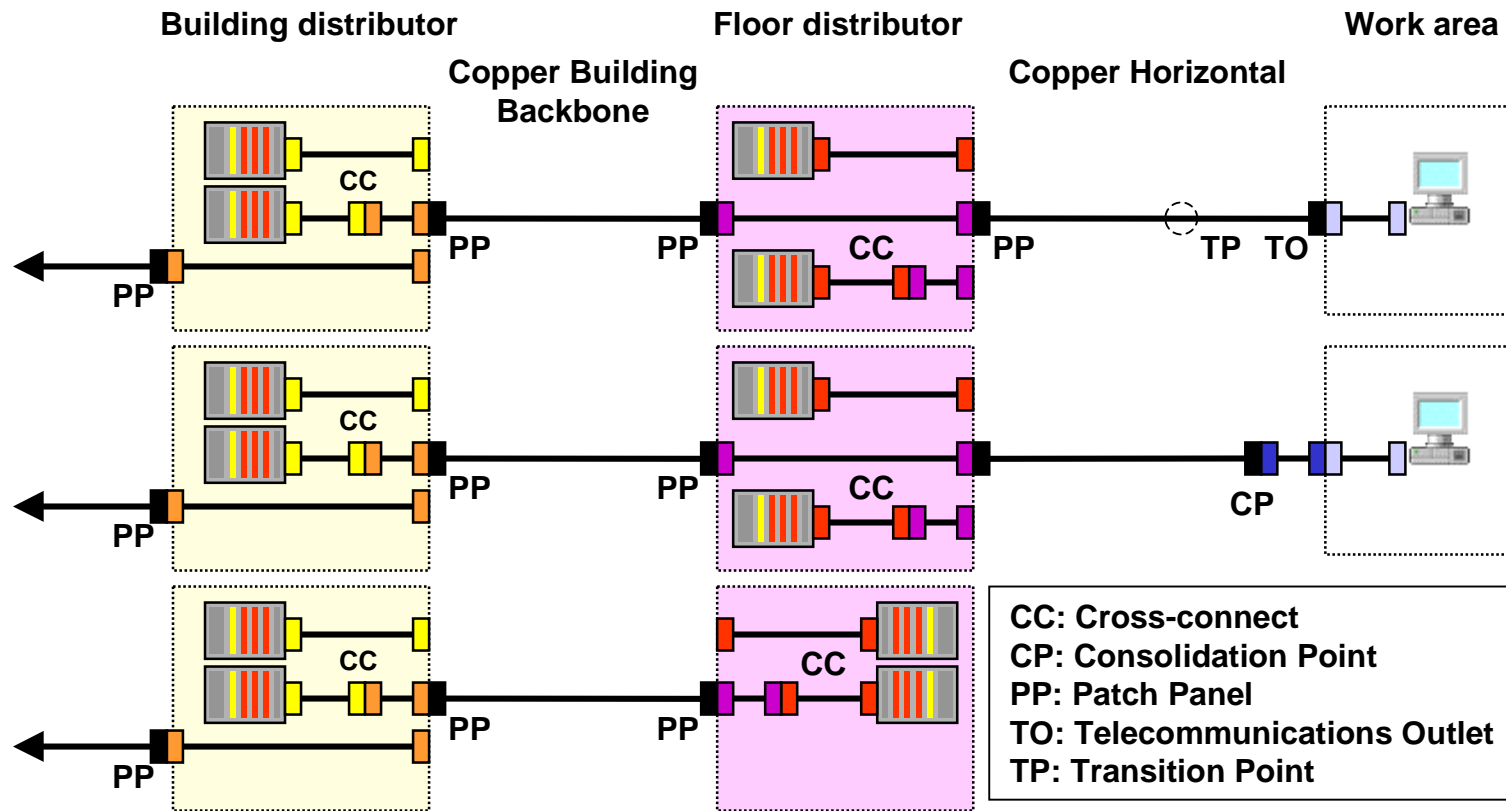

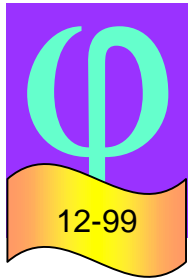

"MIND THE GAP" - A GUIDE TO THE MANAGEMENT OF CABLING PERFORMANCE

Links and channels

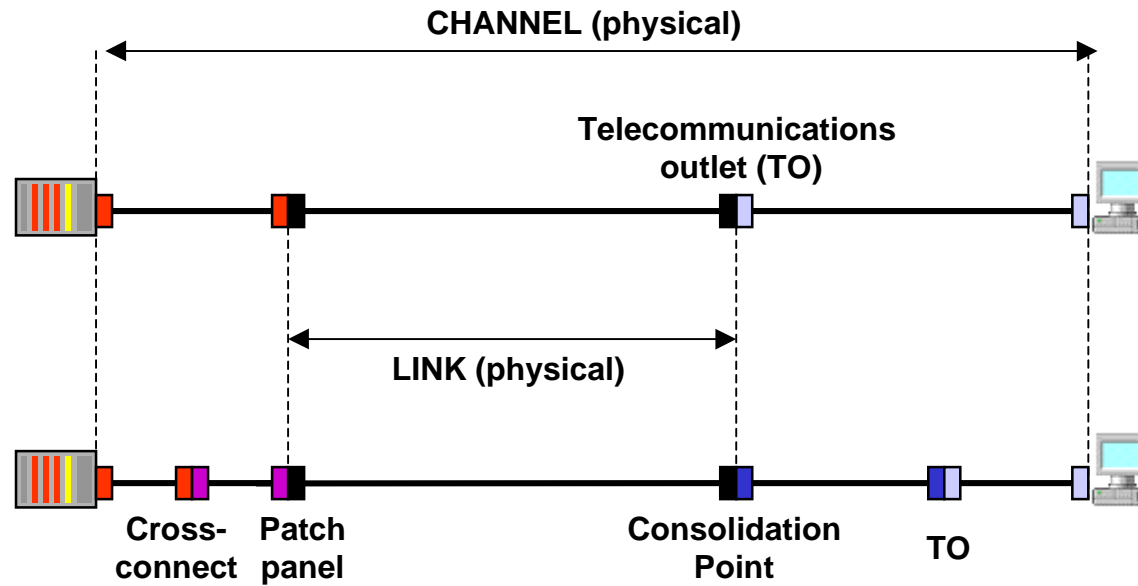

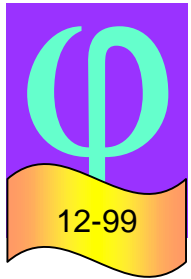

"MIND THE GAP" - A GUIDE TO THE MANAGEMENT OF CABLING PERFORMANCE

Performance limits: Attenuation

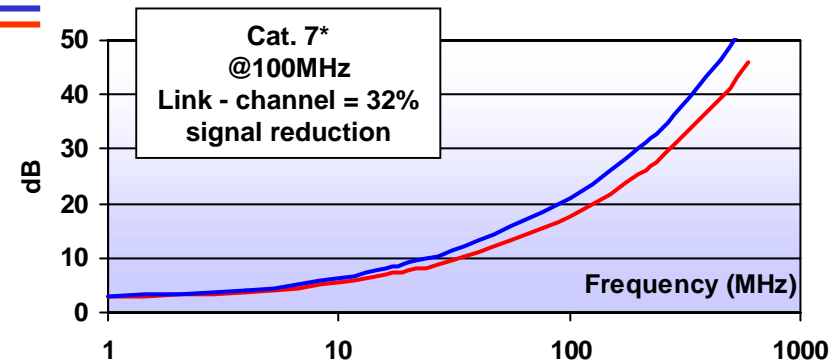
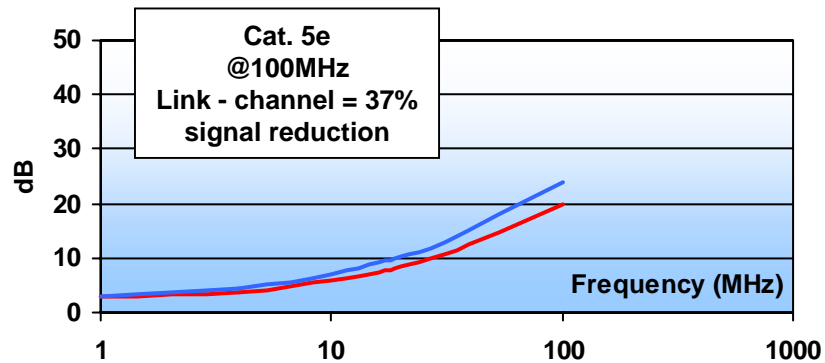
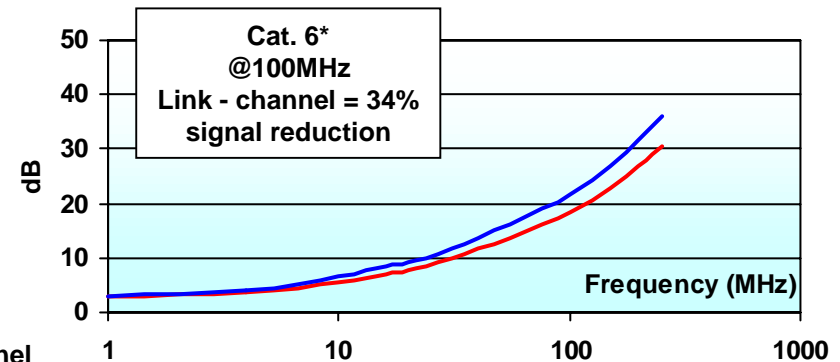
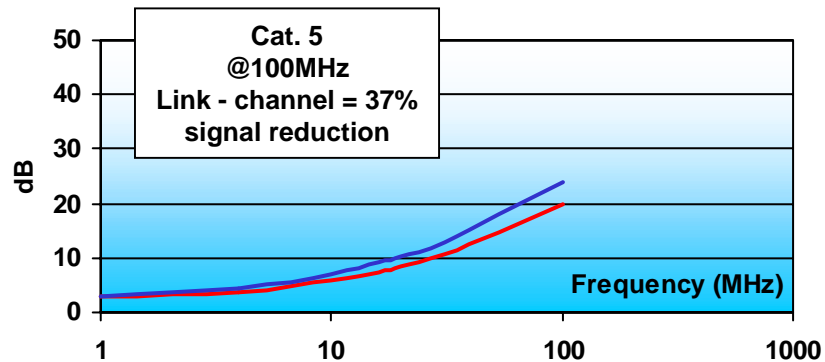

channel
link

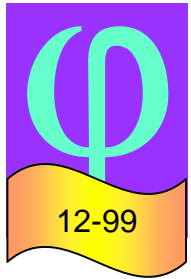

"MIND THE GAP" - A GUIDE TO THE MANAGEMENT OF CABLING PERFORMANCE

Performance limits: PSNEXT

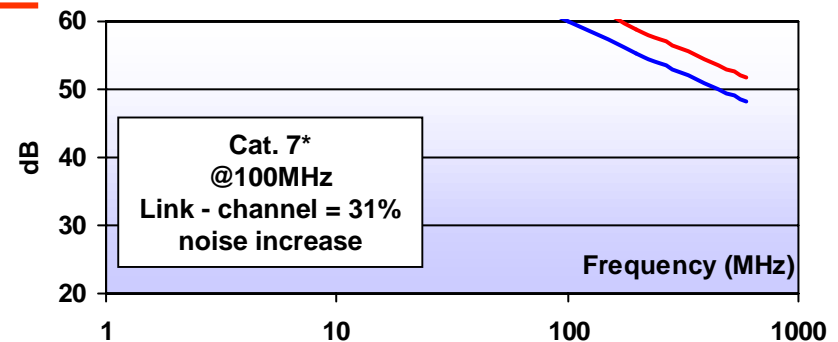
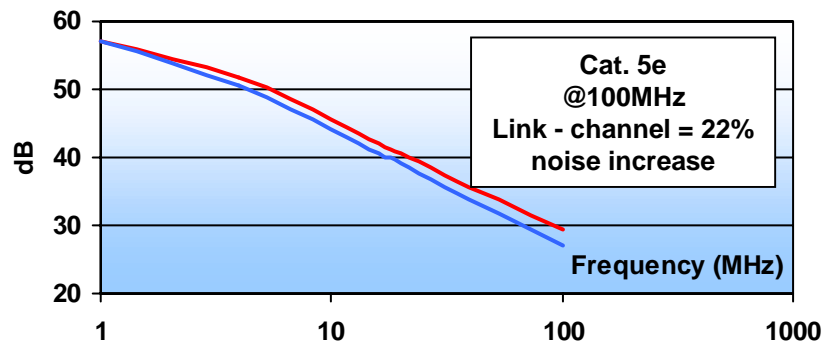
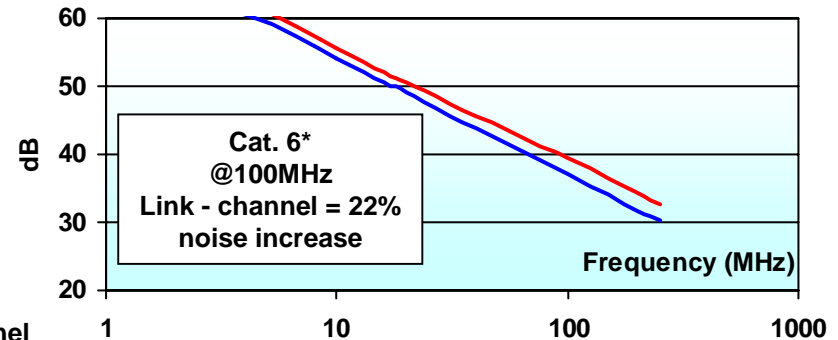
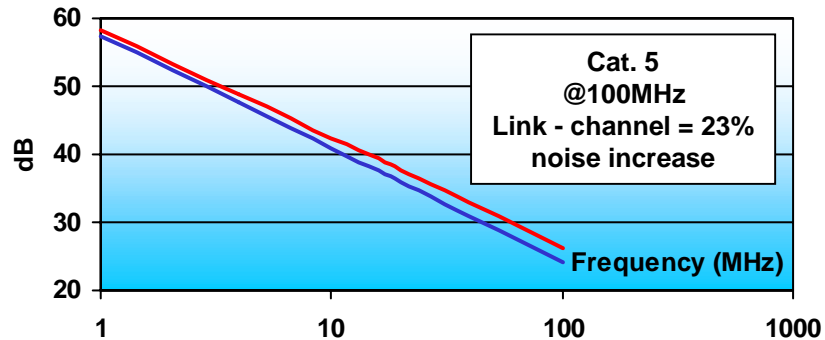

channel
link

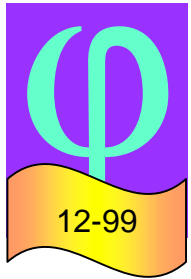

"MIND THE GAP" - A GUIDE TO THE MANAGEMENT OF CABLING PERFORMANCE

Performance limits: PSELFEXT

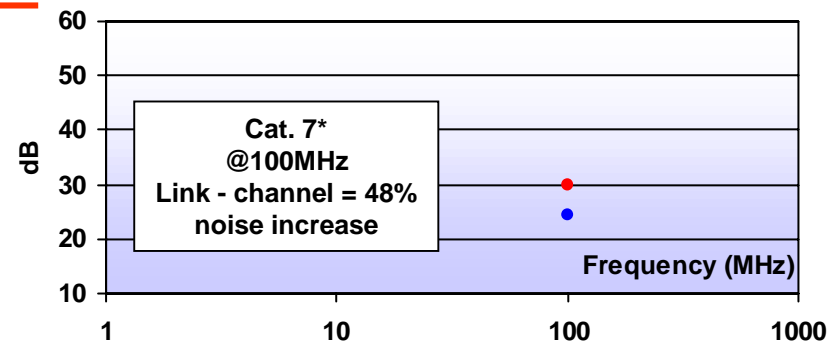
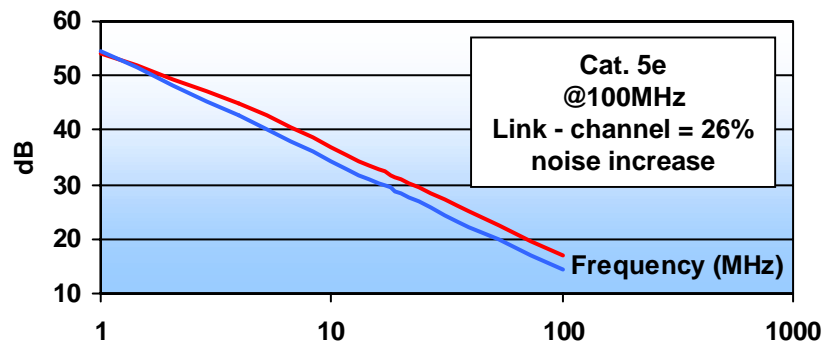
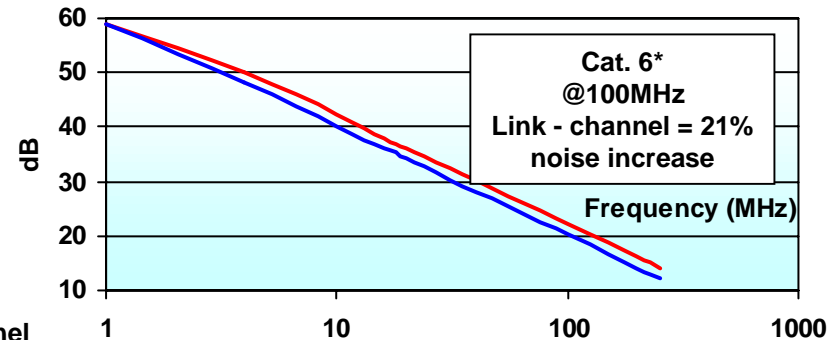
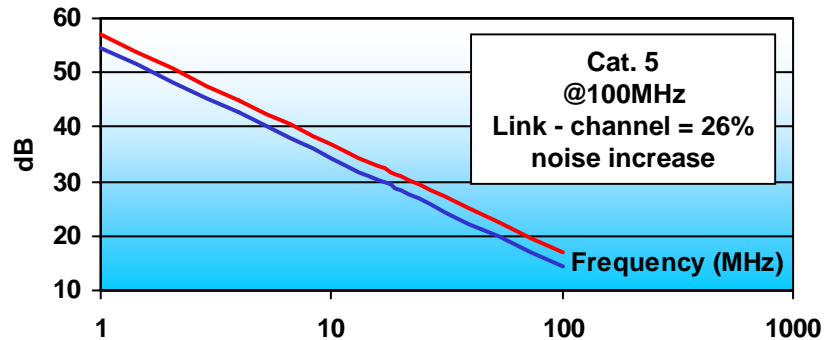

channel
link

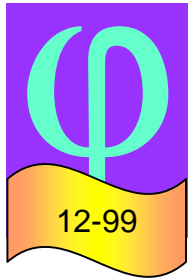

"MIND THE GAP" - A GUIDE TO THE MANAGEMENT OF CABLING PERFORMANCE

Performance limits: Return loss

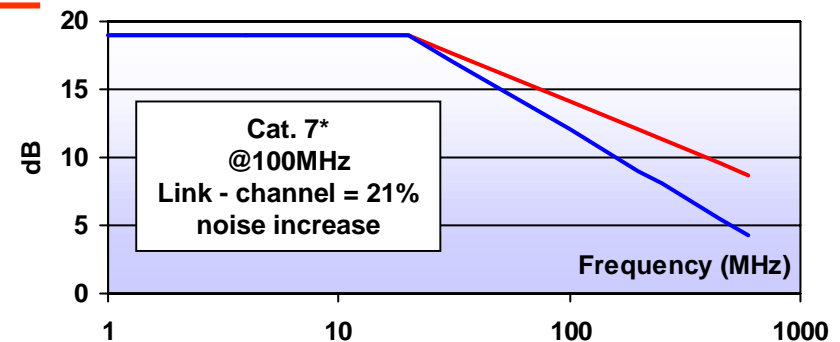
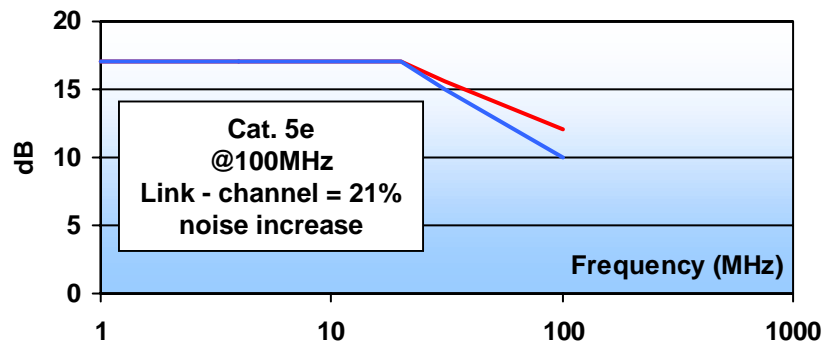
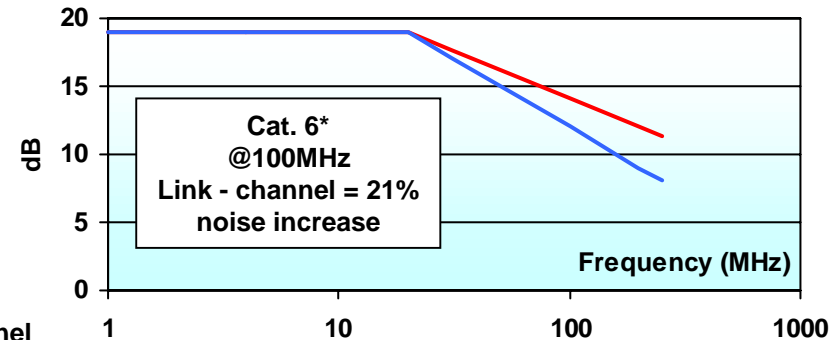
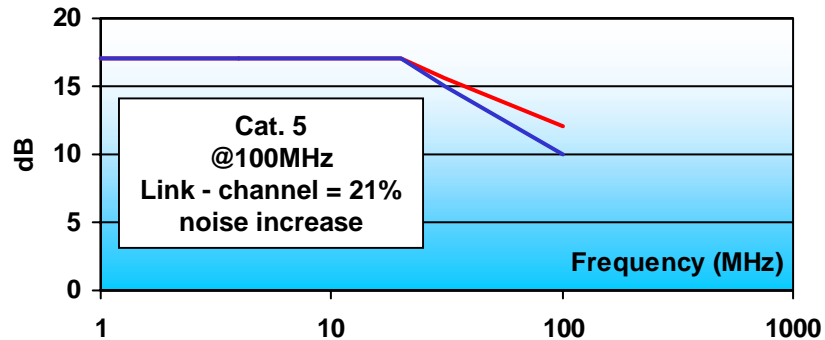

channel
link

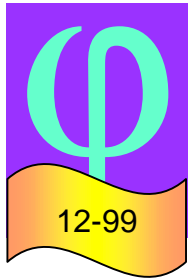

"MIND THE GAP" - A GUIDE TO THE MANAGEMENT OF CABLING PERFORMANCE

Performance: Location

Attenuation is distributed along channel



Return loss is concentrated in cabling close to equipment



ELFEXT/PSELFEXT is concentrated at connections at/close to equipment



NEXT/PSNEXT is concentrated at connections at/close to equipment

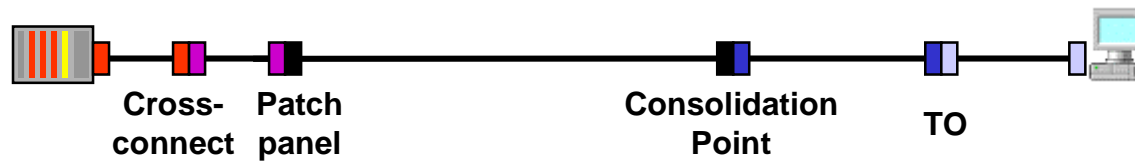

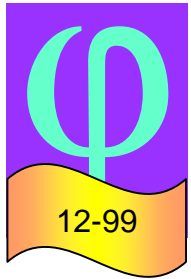

"MIND THE GAP" - A GUIDE TO THE MANAGEMENT OF CABLING PERFORMANCE

Performance: Responsibility

THE USER

- configures 66% - 80% of each channel
- defines 100% of channel performance

**CHANNEL MANAGEMENT IS KEY
TO NETWORK RELIABILITY**

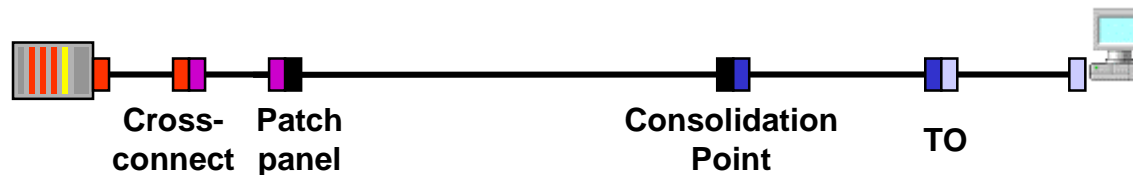

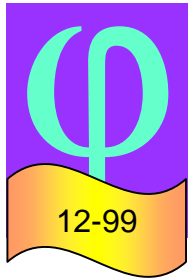

“MIND THE GAP” - A GUIDE TO THE MANAGEMENT OF CABLING PERFORMANCE

The “Channel Gap”

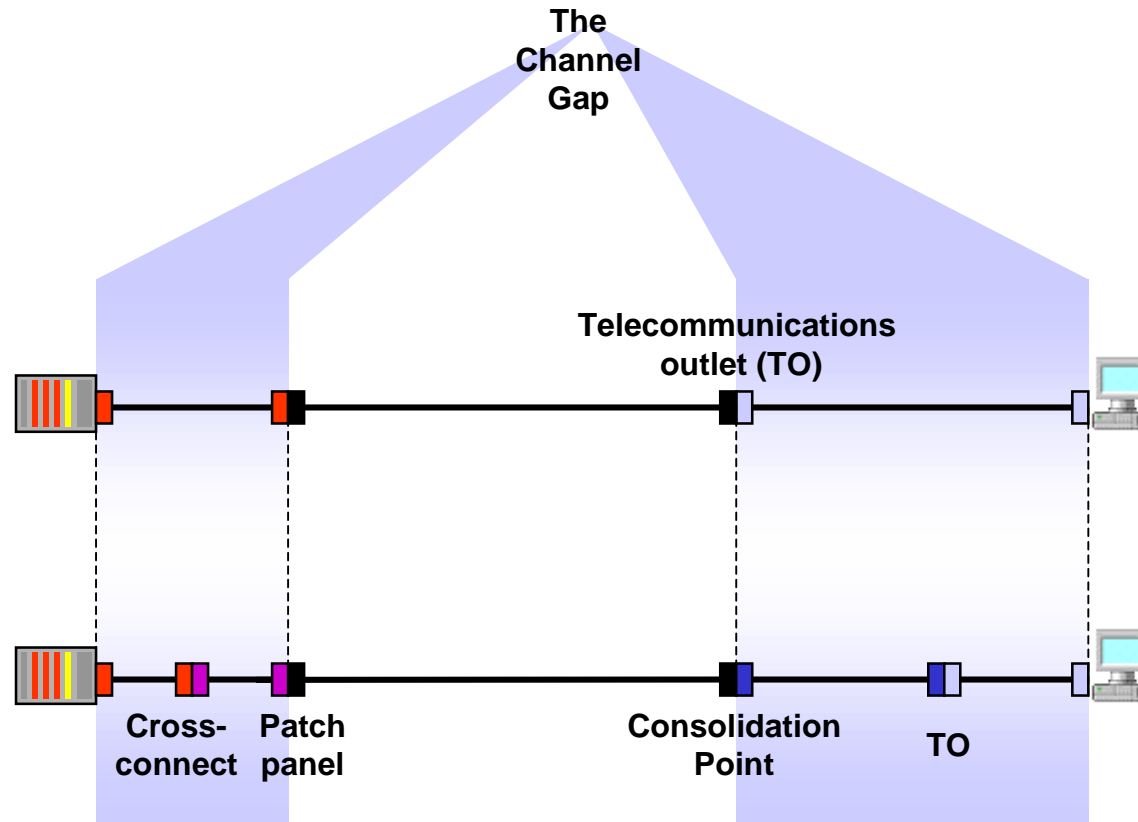

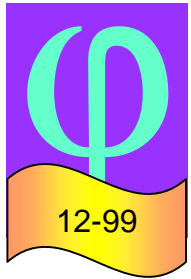

"MIND THE GAP" - A GUIDE TO THE MANAGEMENT OF CABLING PERFORMANCE

The big issues - I

SOCKETS AND PLUGS

Non interoperability

- standards do not guarantee electrical (or even physical) performance of an open system joint
"pending resolution of this guarantees shall be sought from manufacturers"

Backwards incompatibility

- as Category increases, there is no guarantee of backwards compatibility
"Cat. 6 with Cat. 5 may perform below Cat. 5"

Screen continuity/performance

- no agreed standard or specification for inter-component screen connection

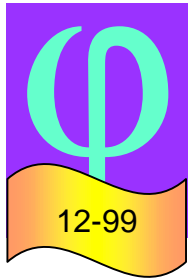

The big issues - II

PATCHCORDS/EQUIPMENT CABLES AND WORK AREA CABLES

Standards

- there are as yet, no standards for cable assemblies (terminated plugs)
"when they arrive they may dis-enfranchise the installed base"

Production tolerances

- variations in termination process may have to be improved
"differences in 0.5-1.0mm of untwisted length have a major impact"

Handling

- as Category increases, so does the sensitivity of patch cords to handling"

Length and temperature

- stranded conductors have higher attenuation than solid conductors
"uncontrolled use of long lead at high temperatures can have dramatic effects"

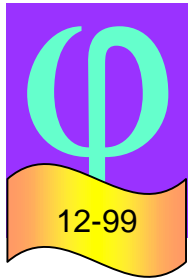

"MIND THE GAP" - A GUIDE TO THE MANAGEMENT OF CABLING PERFORMANCE

The impact of higher Categories

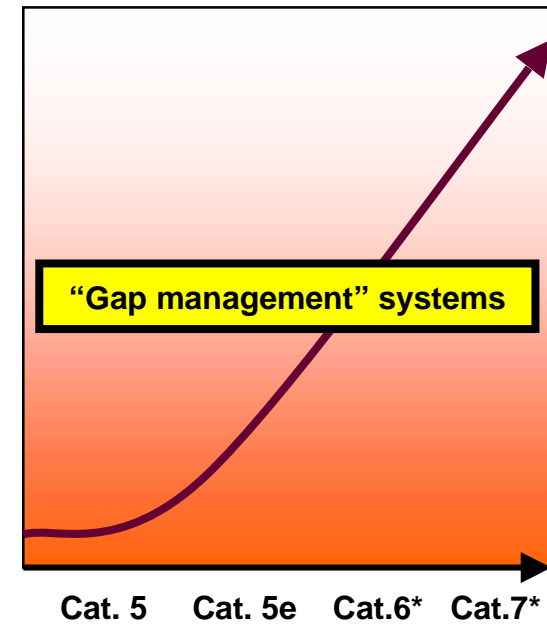
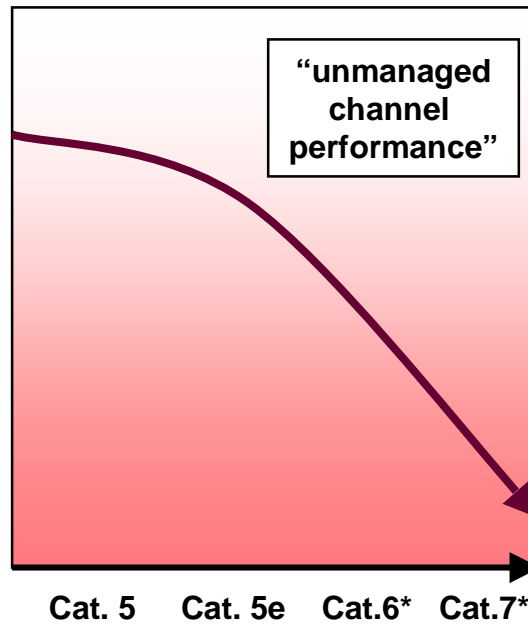
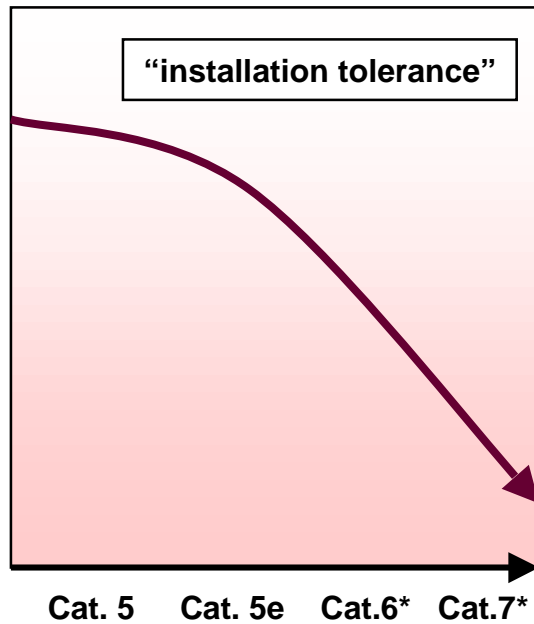

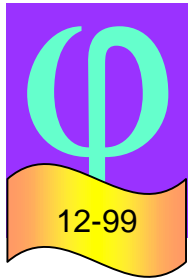

“MIND THE GAP” - A GUIDE TO THE MANAGEMENT OF CABLING PERFORMANCE

Where's the User Manual?

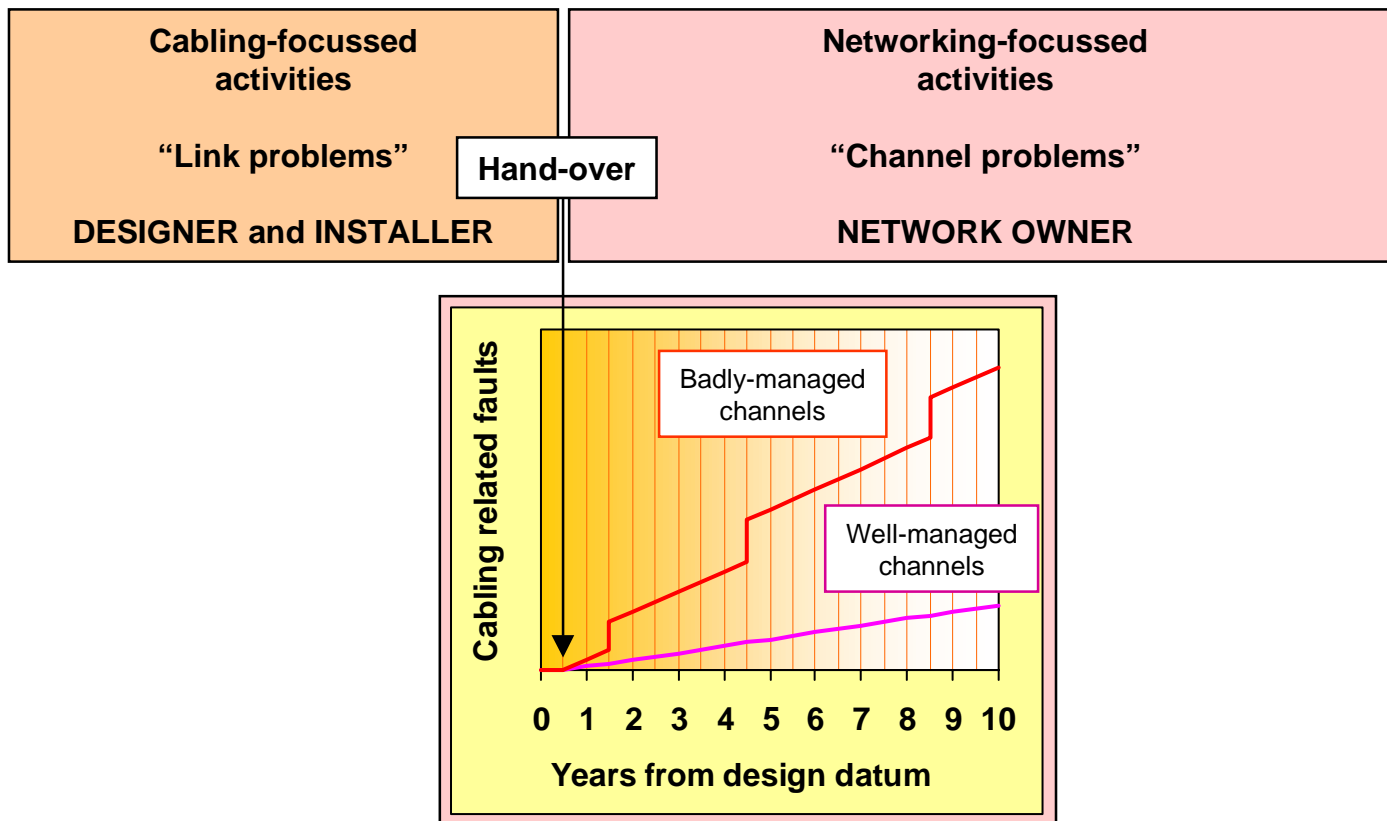

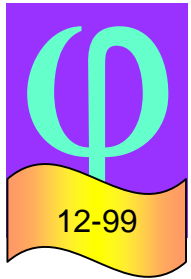

"MIND THE GAP" - A GUIDE TO THE MANAGEMENT OF CABLING PERFORMANCE

Agenda

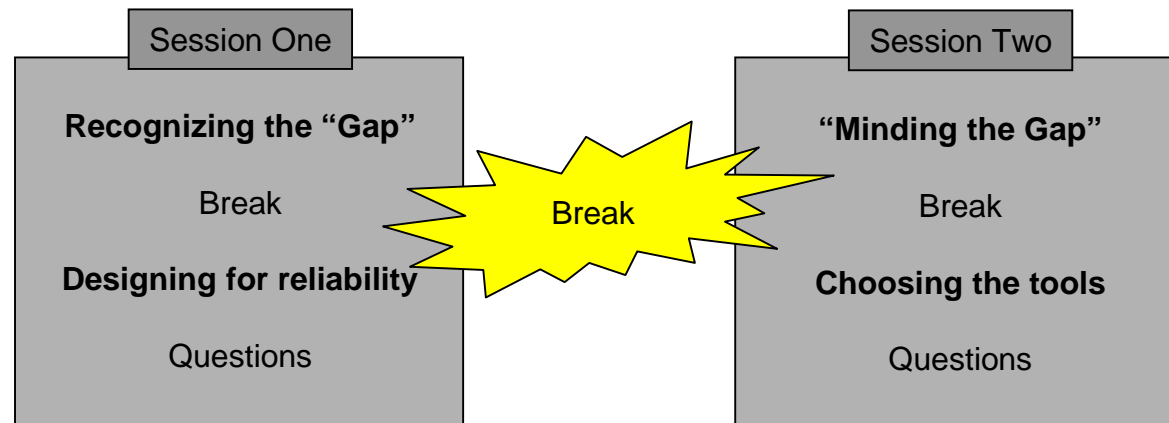

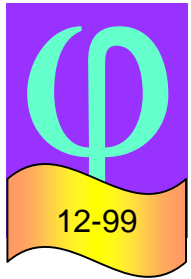

"MIND THE GAP" - A GUIDE TO THE MANAGEMENT OF CABLING PERFORMANCE

Agenda

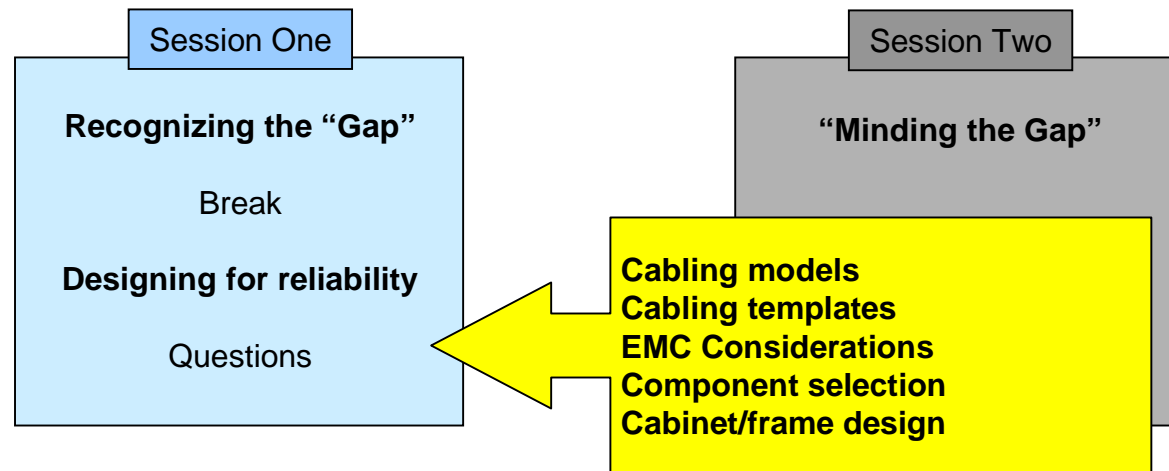

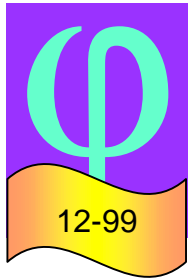

"MIND THE GAP" - A GUIDE TO THE MANAGEMENT OF CABLING PERFORMANCE

Cabling model evolution

PATCHCORDS/EQUIPMENT CABLES AND WORK AREA CABLES

Length and temperature

- **stranded conductors have higher attenuation than solid conductors**
"uncontrolled use of long lead at high temperatures can have dramatic effects"

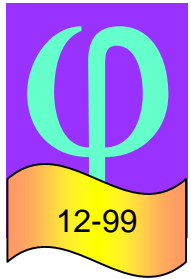

"MIND THE GAP" - A GUIDE TO THE MANAGEMENT OF CABLING PERFORMANCE

Cabling model elements

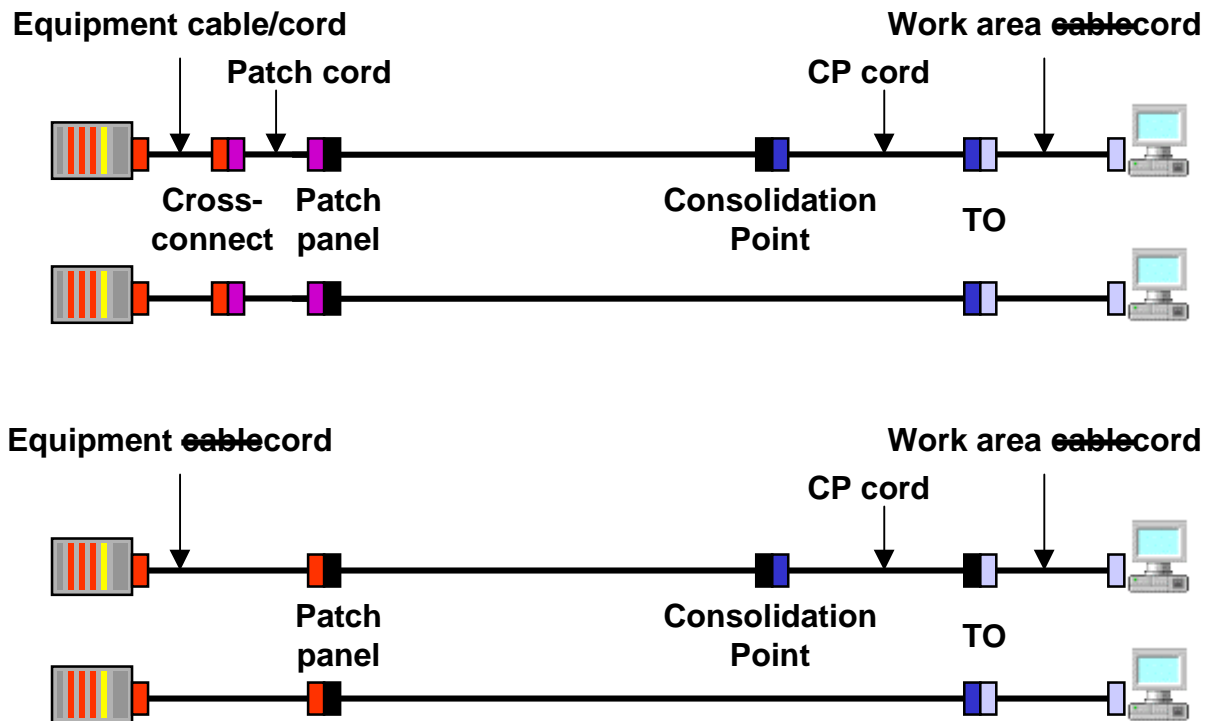

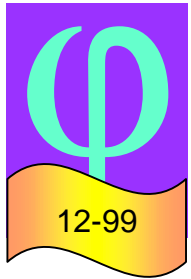

"MIND THE GAP" - A GUIDE TO THE MANAGEMENT OF CABLING PERFORMANCE

Cabling model: old

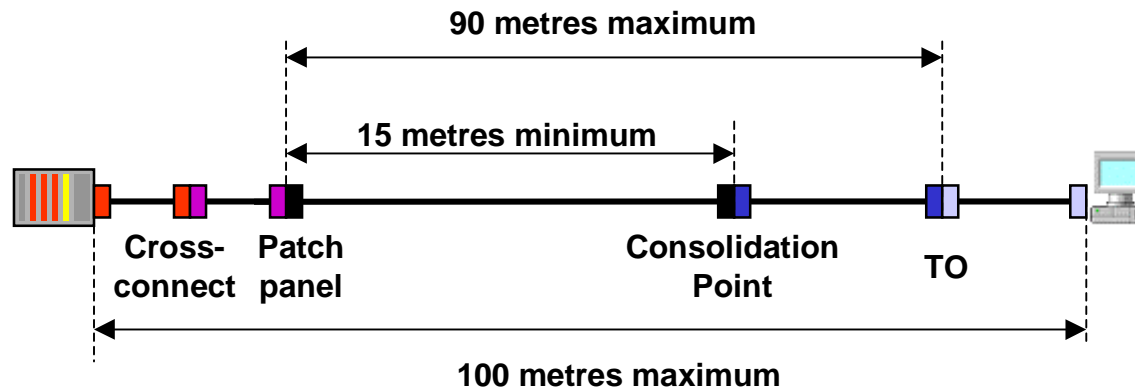

Equipment cable/cord + patchcord + equipment cord = 10 metres maximum

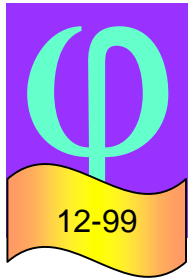

"MIND THE GAP" - A GUIDE TO THE MANAGEMENT OF CABLING PERFORMANCE

Cabling model: new

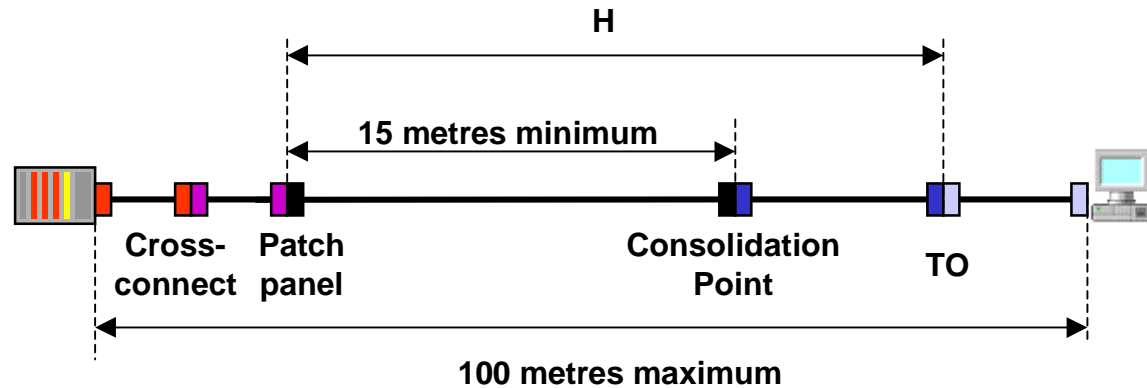

$H = 108 - PX - 2n$
H = 90 metres maximum

$P = 1.2$ for unscreened, $P = 1.5$ for screened
X = length of equipment cable/cord + patchcord + equipment cord
n = number of mated connections (2, 3 or 4)

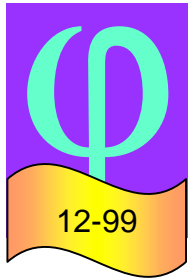

“MIND THE GAP” - A GUIDE TO THE MANAGEMENT OF CABLING PERFORMANCE

Cabling model: T-plus

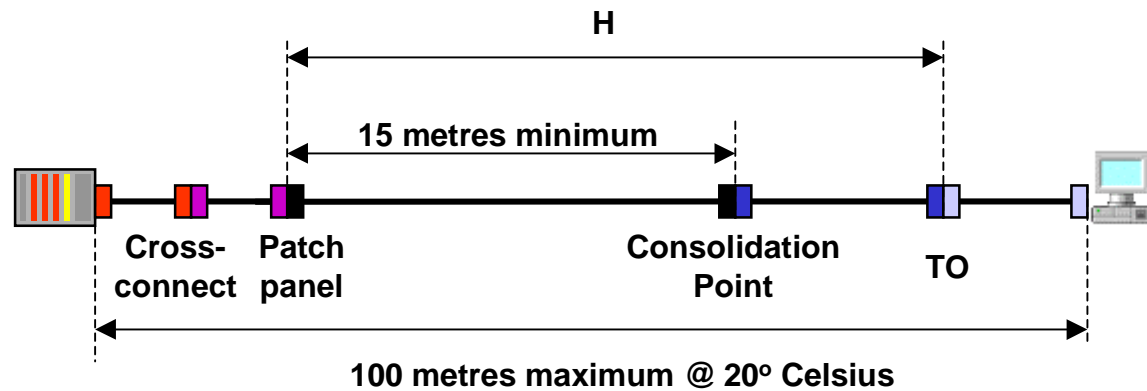

$$H = \frac{108-PX}{1 + (T-20)\alpha} - 2n$$

H = 90 metres maximum

n = number of mated connections (2, 3 or 4)
 P = 1.2 for unscreened, P = 1.5 for screened
 X = length of equipment cable/cord + patchcord + equipment cord and
 T = average temperature over channel length
 α = 0.004 for unscreened and 0.002 for screened

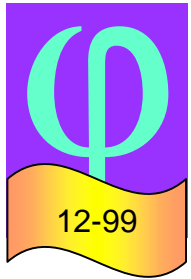

“MIND THE GAP” - A GUIDE TO THE MANAGEMENT OF CABLING PERFORMANCE

T-plus model: examples

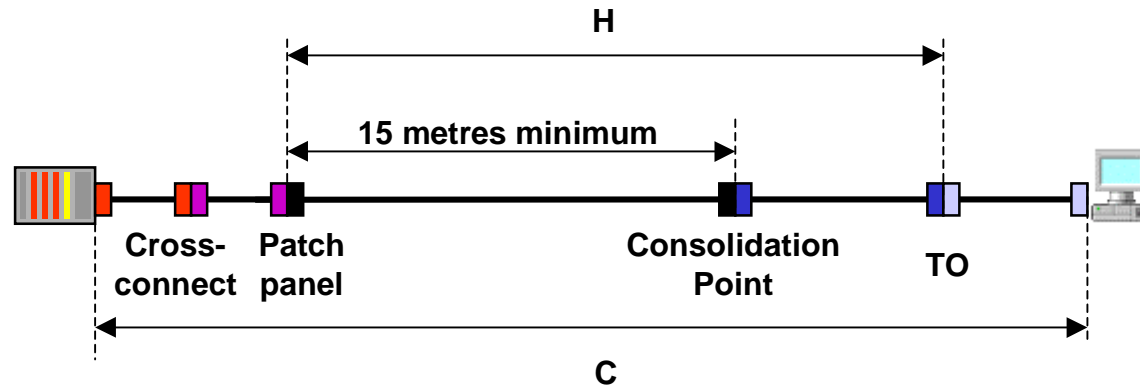

At 20° C

C = 100 metres max.
H = 90 metres max.

X	H (unscreened)	H (screened)
5m	90m	90m
10m	88m	85m
15m	82m	77.5m
20m	76m	70m

$$H = \frac{108-PX}{1 + (T-20)\alpha} - 2n$$

H = 90 metres maximum

At 40° C

C = 92/96 max. (unscreened/screened)
H = 90 metres max.

X	H (unscreened)	H (screened)
5m	86.4m	88.6m
10m	80.9m	81.4m
15m	75.3m	74.2m
20m	69.8m	67m

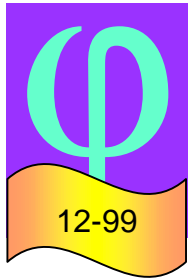

"MIND THE GAP" - A GUIDE TO THE MANAGEMENT OF CABLING PERFORMANCE

T-plus model: ScTP vs. UTP

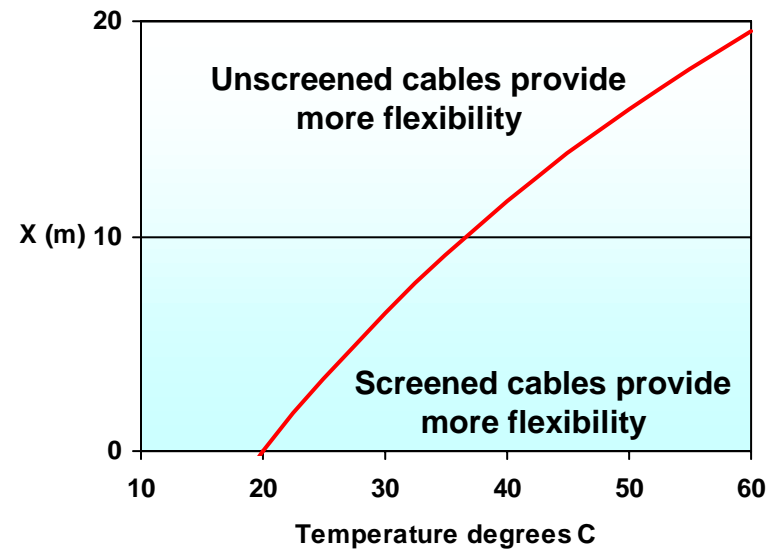
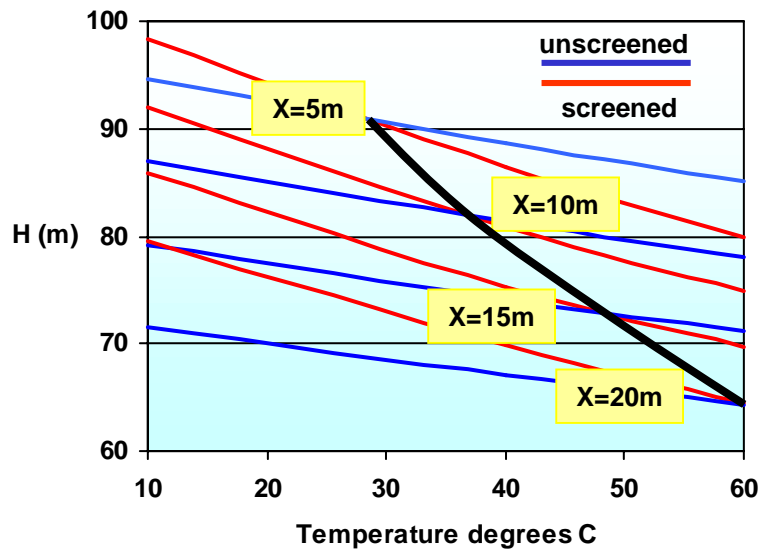

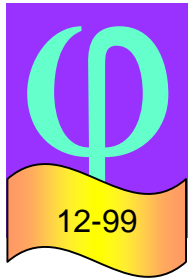

“MIND THE GAP” - A GUIDE TO THE MANAGEMENT OF CABLING PERFORMANCE

Cabling model: T+CP

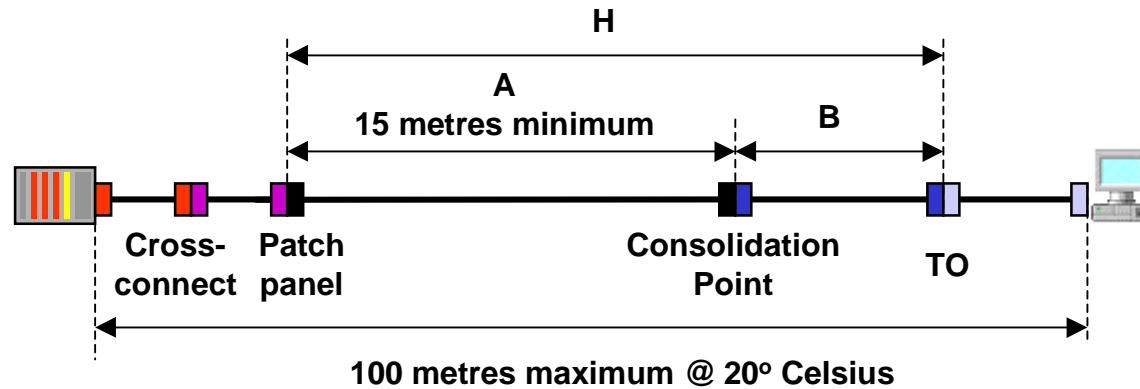

$$H = \frac{108-PX}{1 + (T-20)\alpha} - 2n$$

assumes that the CP cord is of solid construction

If stranded constructions are used then

$$A + PB = \frac{108-PX}{1 + (T-20)\alpha} - 2n$$

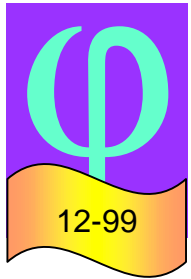

"MIND THE GAP" - A GUIDE TO THE MANAGEMENT OF CABLING PERFORMANCE

Cabling template design - I



PHASE 1: TEMPLATE DIMENSIONS

Definition of maximum lengths for

A: equipment cables/cords

B: patchcords

C: CP cords

D: work area cables

providing a maximum value for H

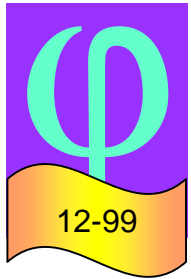

"MIND THE GAP" - A GUIDE TO THE MANAGEMENT OF CABLING PERFORMANCE

Template management

SOCKETS AND PLUGS

Non interoperability

- standards do not guarantee electrical (or even physical) performance of an open system joint
"pending resolution of this guarantees shall be sought from manufacturers"

Backwards incompatibility

- as Category increases, there is no guarantee of backwards compatibility
"Cat. 6 with Cat. 5 may perform below Cat. 5"

Screen continuity/performance

- no agreed standard or specification for inter-component screen connection

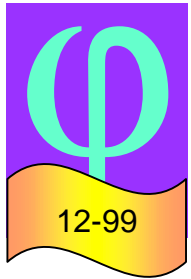

"MIND THE GAP" - A GUIDE TO THE MANAGEMENT OF CABLING PERFORMANCE

Cabling template design - II

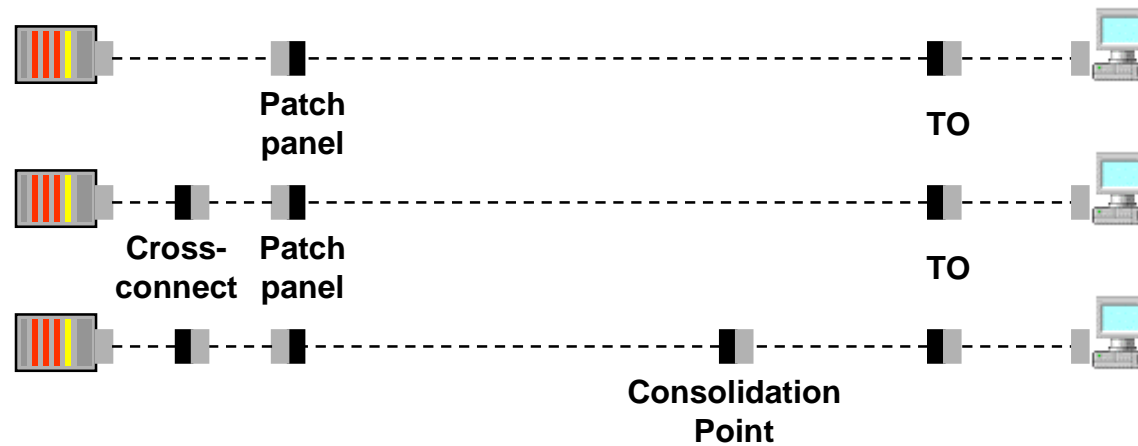

PHASE 2: SYSTEM SOCKET MANUFACTURERS

Definition of system socket at:

- TO
- patch panels
- cross-connect panels

providing supported plug

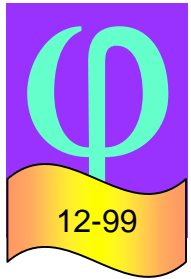

"MIND THE GAP" - A GUIDE TO THE MANAGEMENT OF CABLING PERFORMANCE

Cabling template design - III

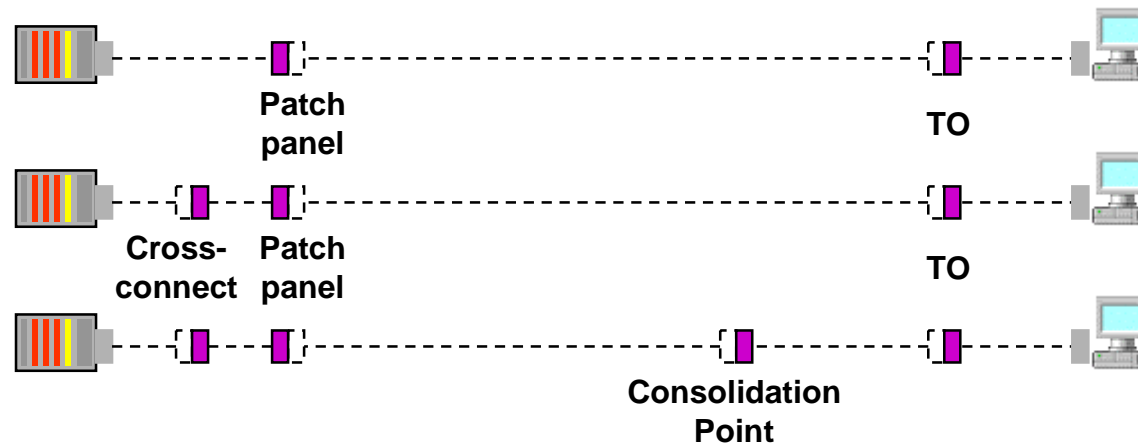

PHASE 3: SYSTEM PLUG MANUFACTURERS

Completes the specification of connectivity and length for:

- patchcords
- CP cords

Provides template for:

- equipment/cables/cords
- work area cords

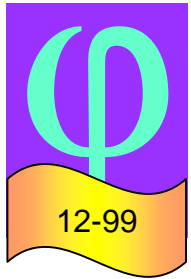

“MIND THE GAP” - A GUIDE TO THE MANAGEMENT OF CABLING PERFORMANCE

Cabling template design - IV



PHASE 4: THE EQUIPMENT INTERFACE

The biggest challenge of all

Equipment manufacturers change sockets from batch-to-batch

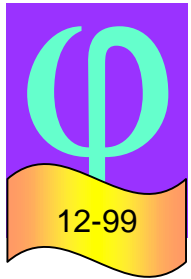

“MIND THE GAP” - A GUIDE TO THE MANAGEMENT OF CABLING PERFORMANCE

EMC considerations: technical

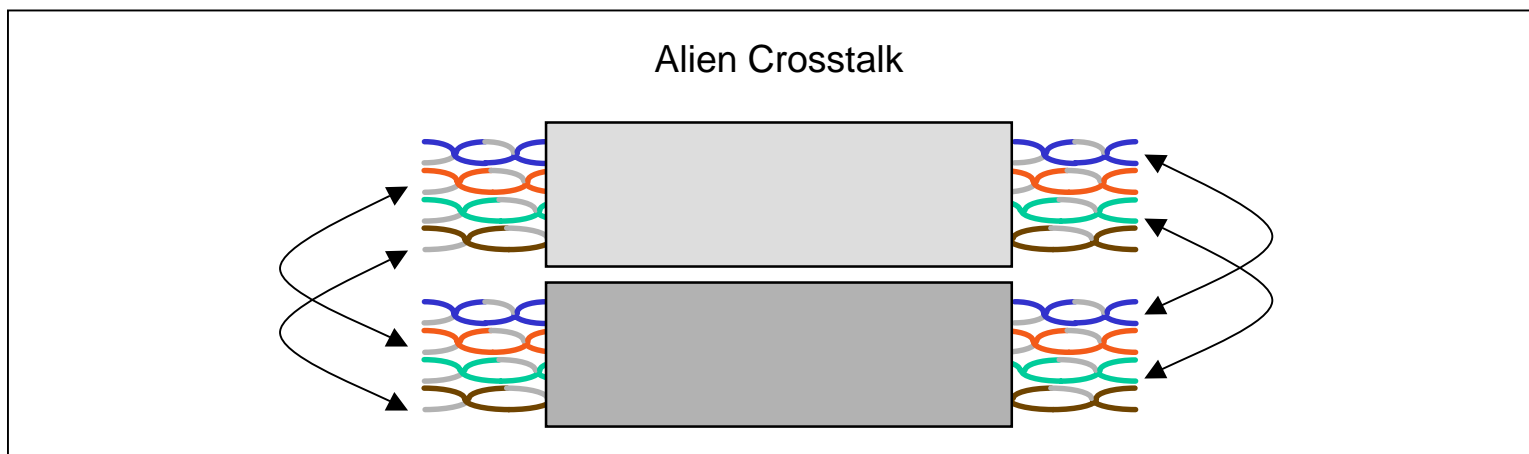
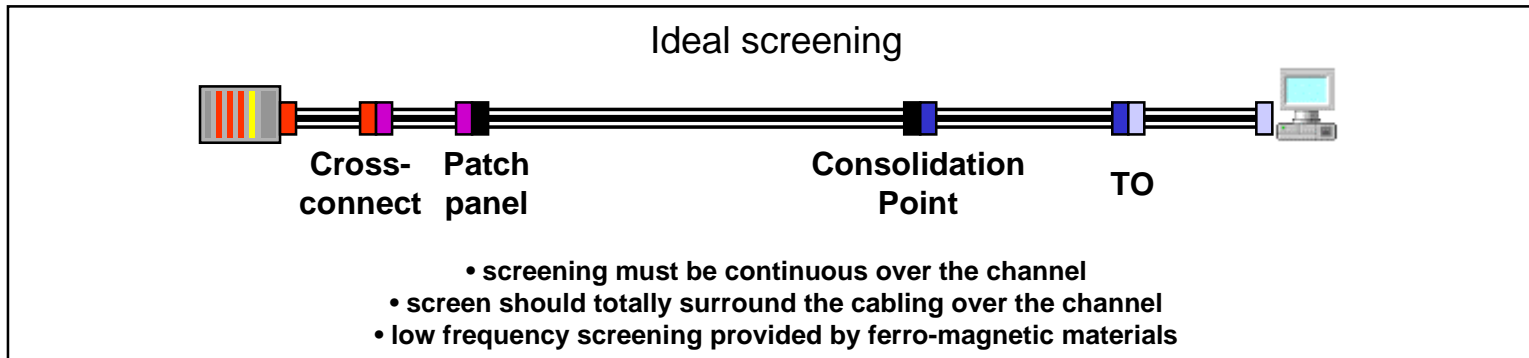

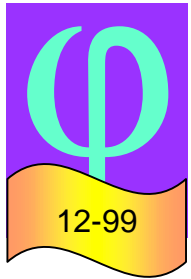

"MIND THE GAP" - A GUIDE TO THE MANAGEMENT OF CABLING PERFORMANCE

EMC considerations: legal

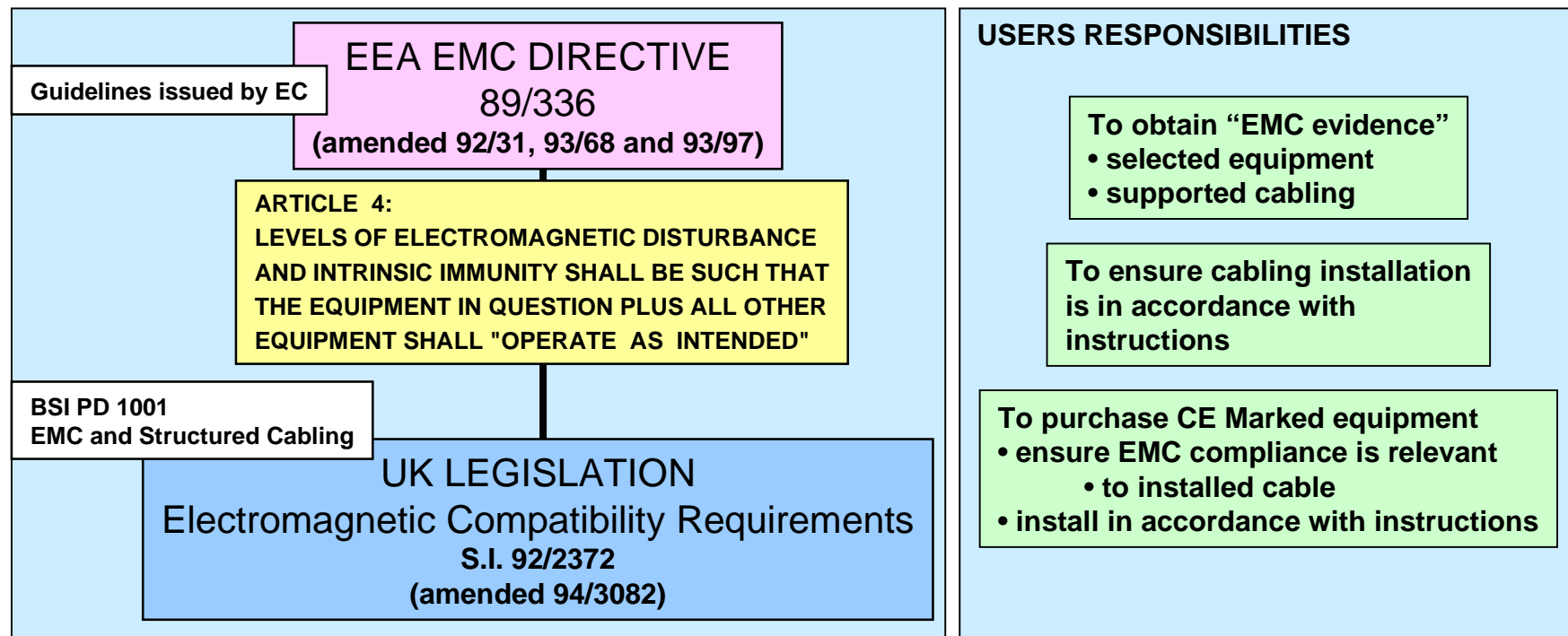

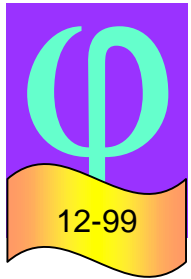

“MIND THE GAP” - A GUIDE TO THE MANAGEMENT OF CABLING PERFORMANCE

Component selection

Category	100MB/s support	1000MB/s support	Performance margin	Management risk	>1000MB/s support
5 (1995)	✓	✗	✗	✗	✗
5 (1999)	✓	✓	specific	✓	✗
5e	✓	✓	matched	✓	✗
6	✓	✓	✓	✓✓	✓
7	✓	✓	✓	✓✓	✓

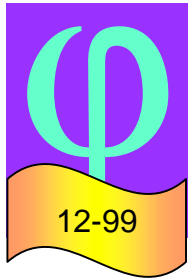

“MIND THE GAP” - A GUIDE TO THE MANAGEMENT OF CABLING PERFORMANCE

Cabinet/frame design

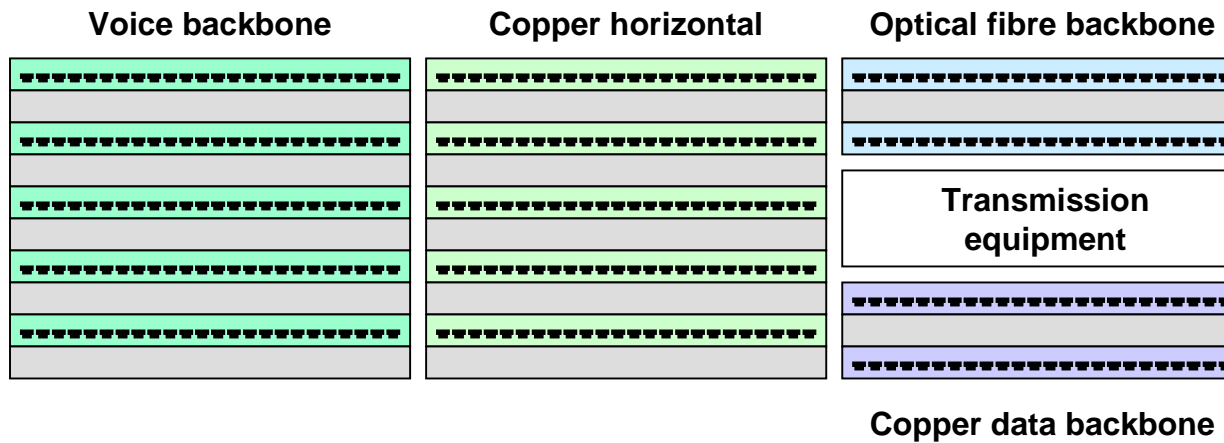

KEY FEATURES

- plenty of space - patch management
- shortest possible routes
- minimum length cords
- recessed panels

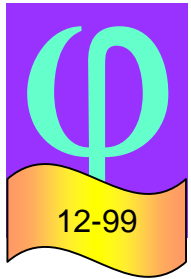

"MIND THE GAP" - A GUIDE TO THE MANAGEMENT OF CABLING PERFORMANCE

Agenda

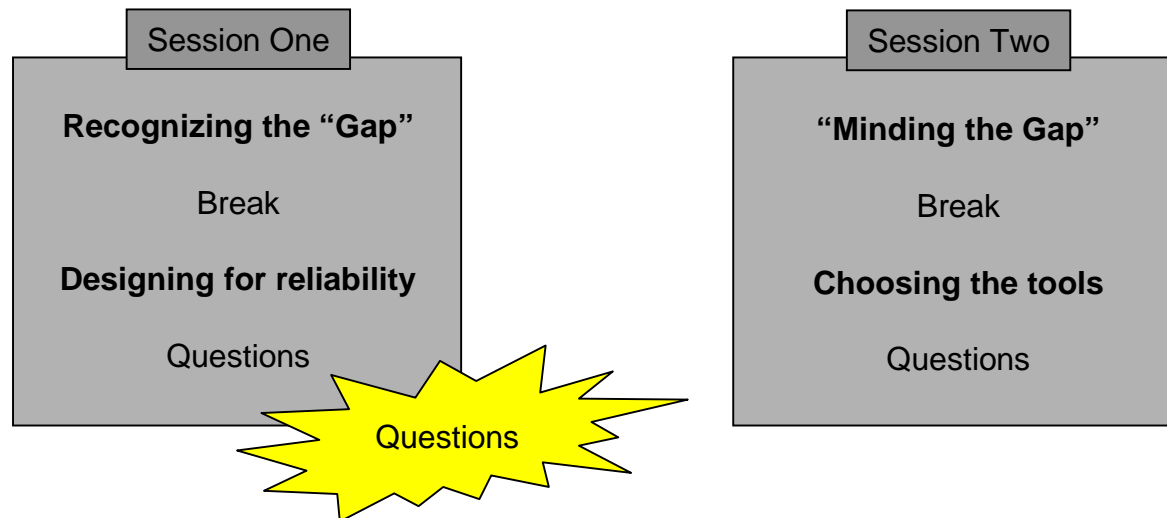

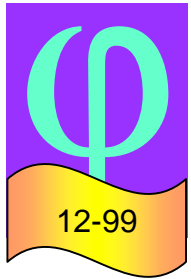

"MIND THE GAP" - A GUIDE TO THE MANAGEMENT OF CABLING PERFORMANCE

Agenda

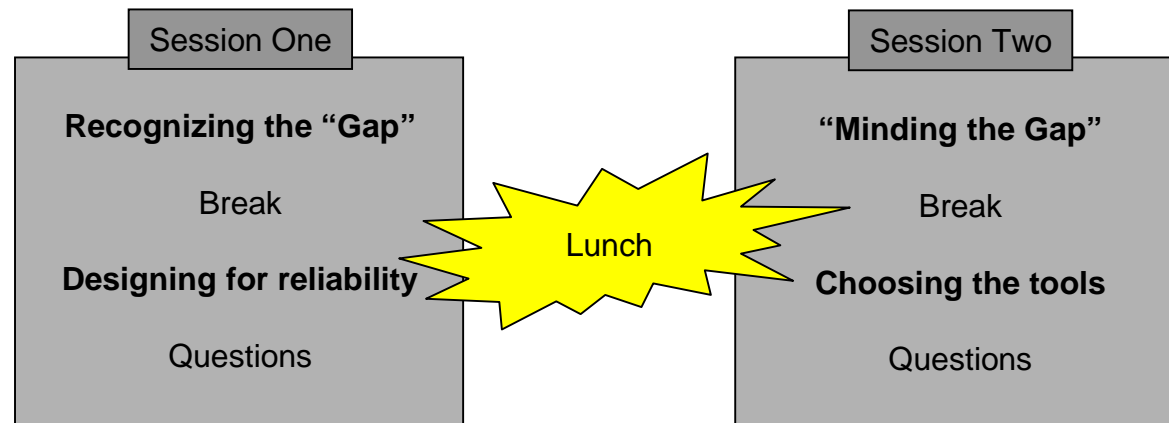

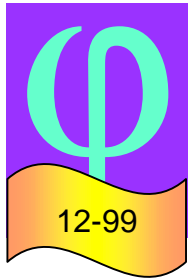

"MIND THE GAP" - A GUIDE TO THE MANAGEMENT OF CABLING PERFORMANCE

Agenda

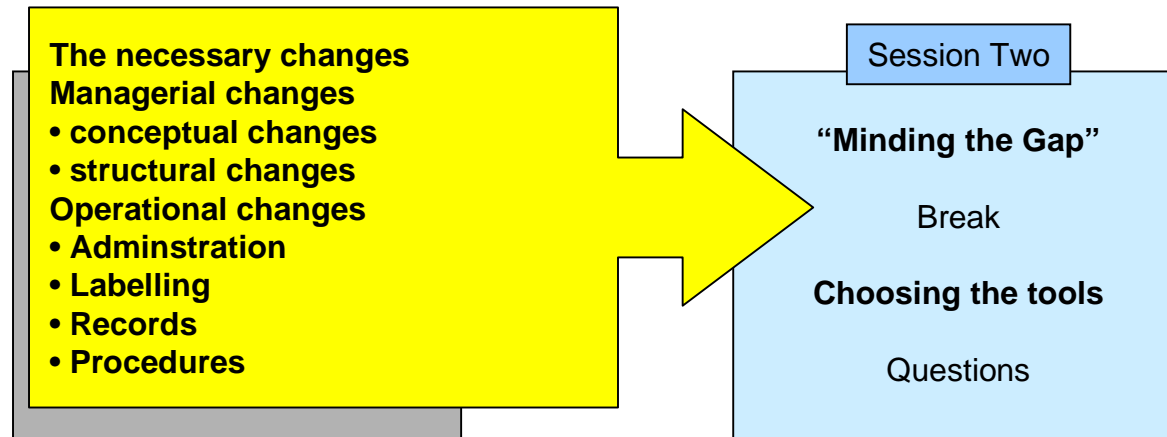

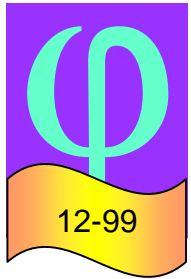

"MIND THE GAP" - A GUIDE TO THE MANAGEMENT OF CABLING PERFORMANCE

The necessary changes

MANAGERIAL

- enhanced profile for infrastructure matters
- establishment of connectivity management group (CMG)
- integration of voice and data management

OPERATIONAL

- administration system
- development of formal procedures
 - strict adherence
- prevention of rogue behaviour

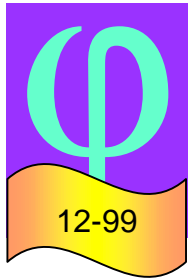

"MIND THE GAP" - A GUIDE TO THE MANAGEMENT OF CABLING PERFORMANCE

The wrong profile

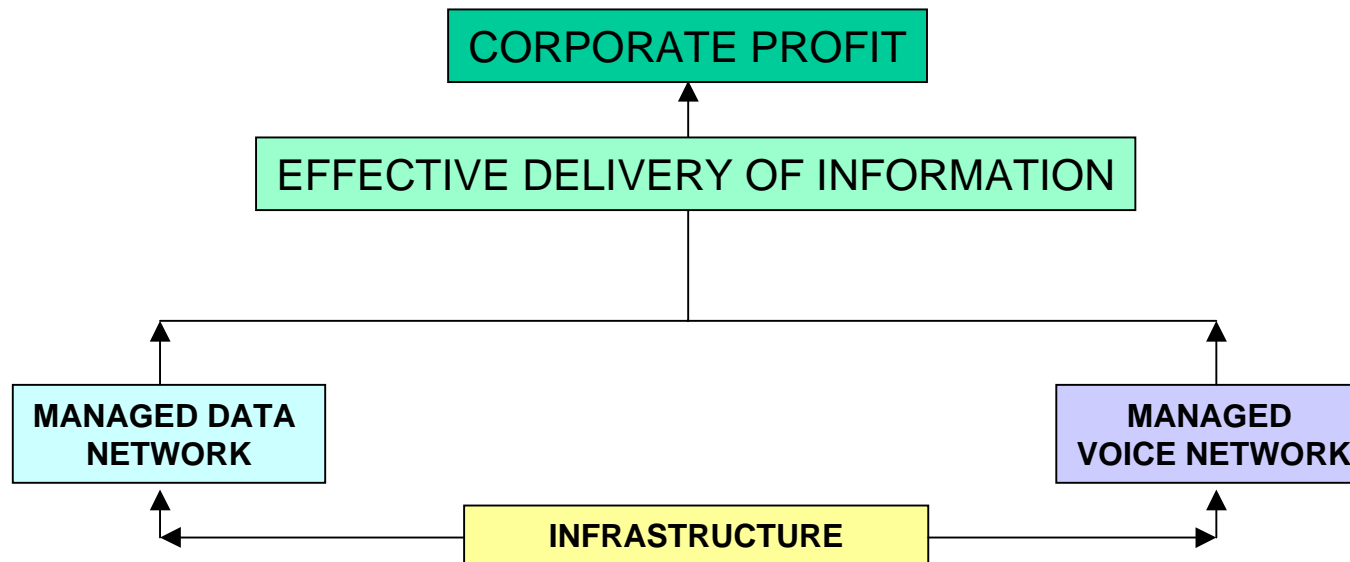

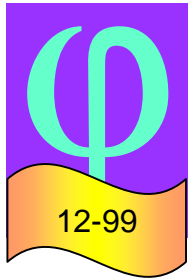

"MIND THE GAP" - A GUIDE TO THE MANAGEMENT OF CABLING PERFORMANCE

The right profile

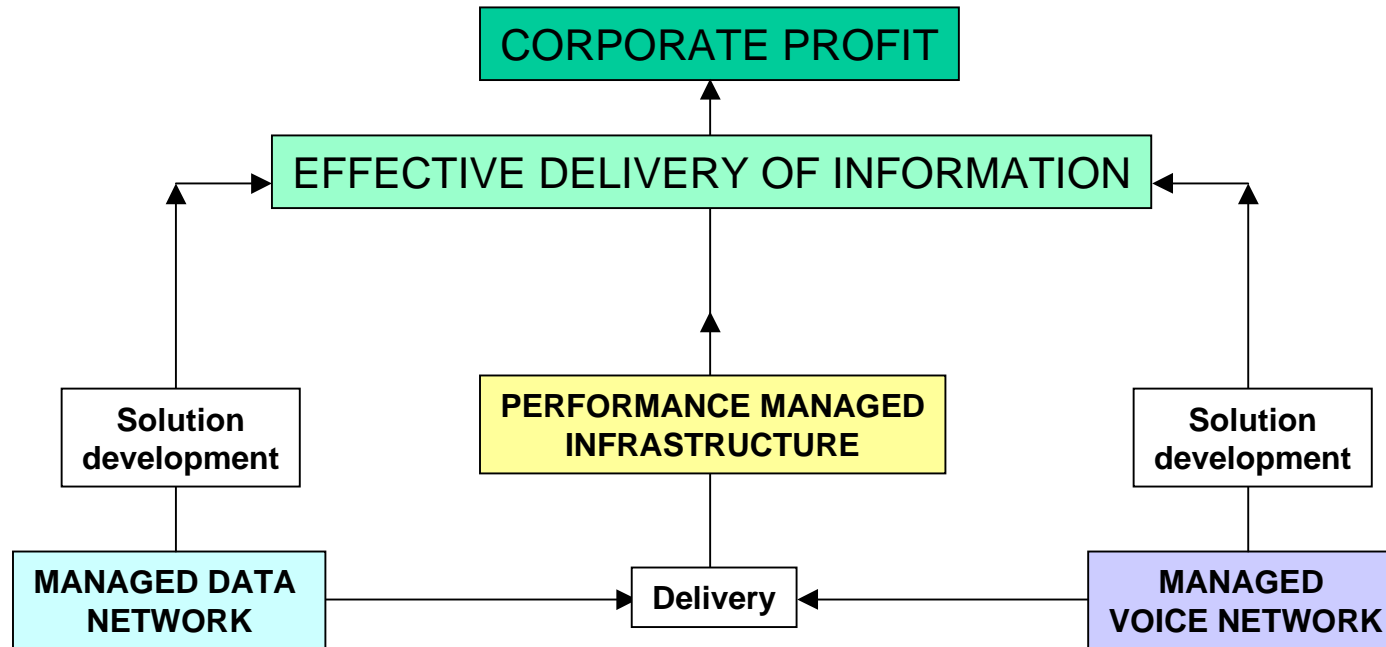

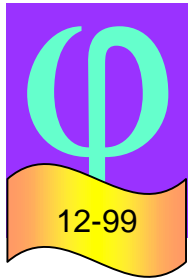

“MIND THE GAP” - A GUIDE TO THE MANAGEMENT OF CABLING PERFORMANCE

Connectivity management group

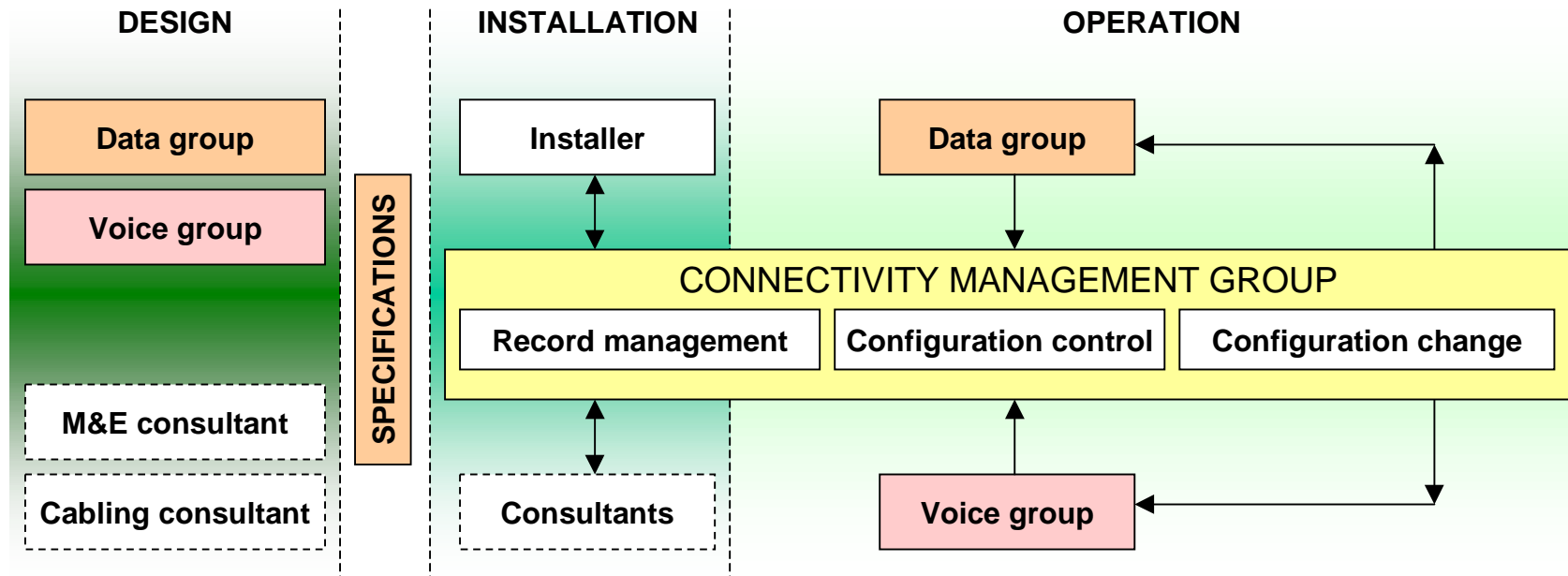

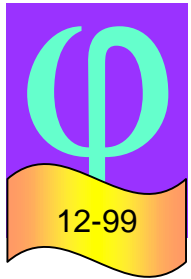

“MIND THE GAP” - A GUIDE TO THE MANAGEMENT OF CABLING PERFORMANCE

Telecommunications integration

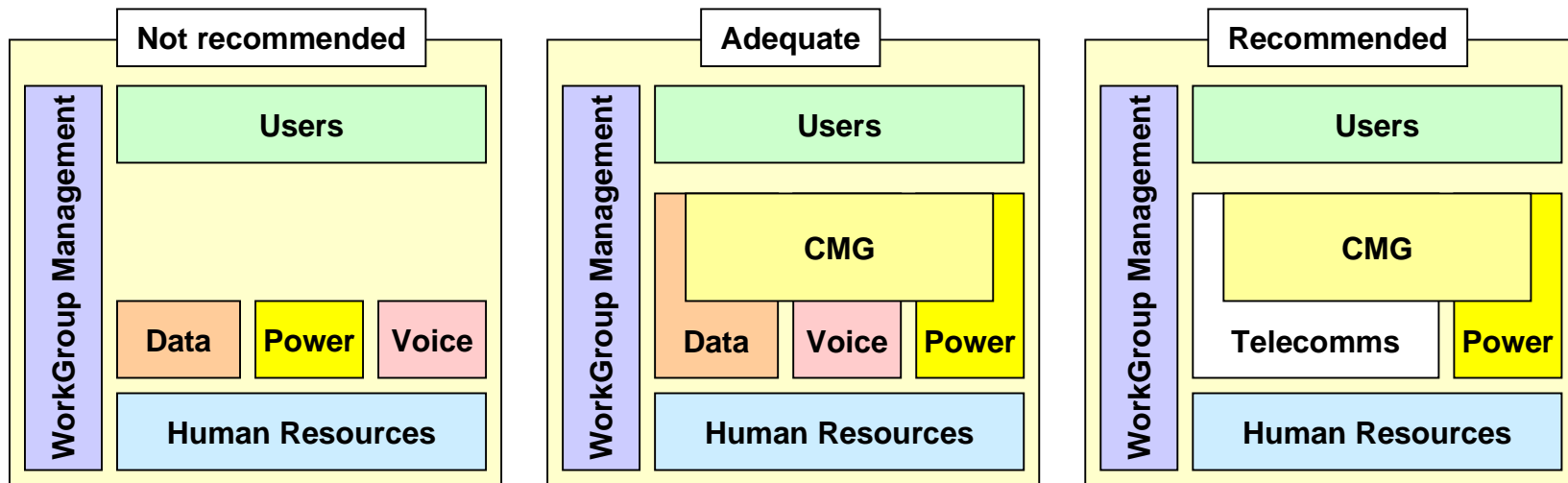

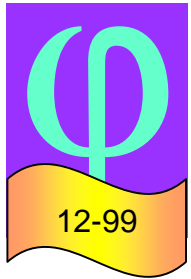

"MIND THE GAP" - A GUIDE TO THE MANAGEMENT OF CABLING PERFORMANCE

Administration

THE MOST IMPORTANT DECISION EVER MADE

ADMINISTRATION

according to EN 50174-1 (expected to be published in March)

- **identification scheme**
- **labelling system**
- **records**

ADMINISTRATION

according to The Cabling Partnership

- **procurement**
- **configuration control**
- **change procedures**
- **emergency procedures**
- **inspection systems**

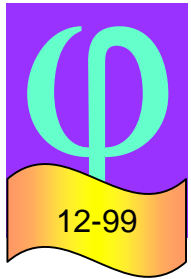

“MIND THE GAP” - A GUIDE TO THE MANAGEMENT OF CABLING PERFORMANCE

Administration: EN 50174-1

		LABELLING	RECORDS
PATHWAYS AND SPACES	UNIQUE and UNAMBIGUOUS IDENTIFIER	Pathways <ul style="list-style-type: none"> • at entry to spaces from pathways Spaces <ul style="list-style-type: none"> • at entry to pathways from spaces 	Pathways <ul style="list-style-type: none"> • interconnected spaces • type of pathway system • bonding points • fill details Spaces <ul style="list-style-type: none"> • type location • pathways served • equipment contained • services provided
FIXED CABLES, BUNDLES AND FLEXIBLE CABLES		At both ends At entry to spaces At each joint (multipair cables)	<ul style="list-style-type: none"> • cable type • length • installation date • termination point identifiers • pathways used • grounding point
TERMINATION POINTS		At each termination point including <ul style="list-style-type: none"> • Consolidation Points • ports 	<ul style="list-style-type: none"> • connection type • location (space, cabinet/frame, panel) • cable identifier • test results • application and connectivity path
EARTHS/BONDS (GENERIC CABLING)		All elements	<ul style="list-style-type: none"> • element type • location • connectivity path • test results (where appropriate)

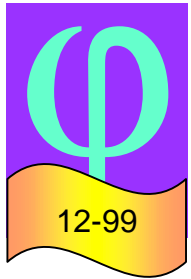

“MIND THE GAP” - A GUIDE TO THE MANAGEMENT OF CABLING PERFORMANCE

Labelling: channel components

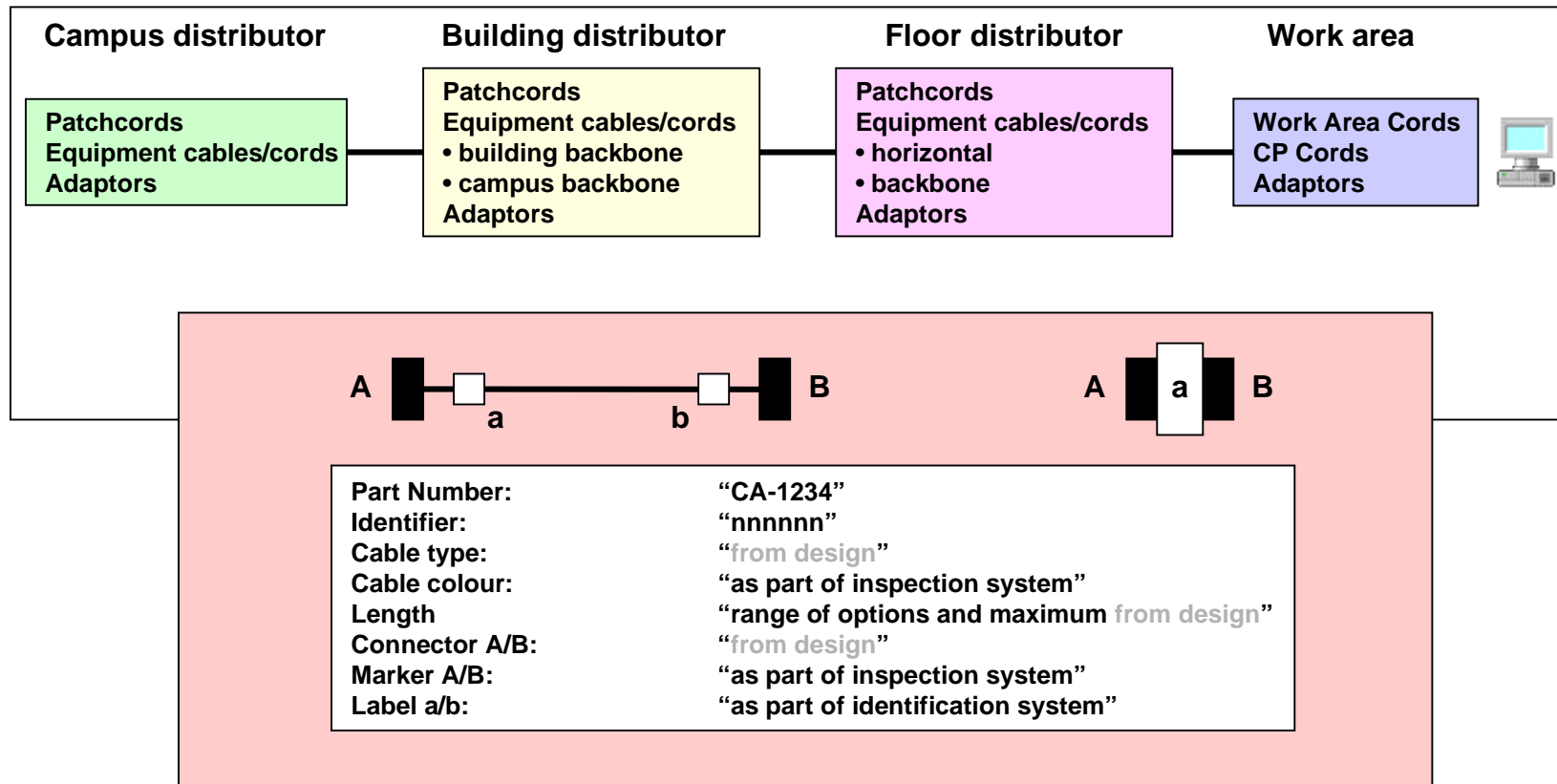

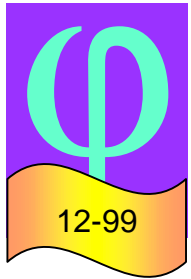

Records

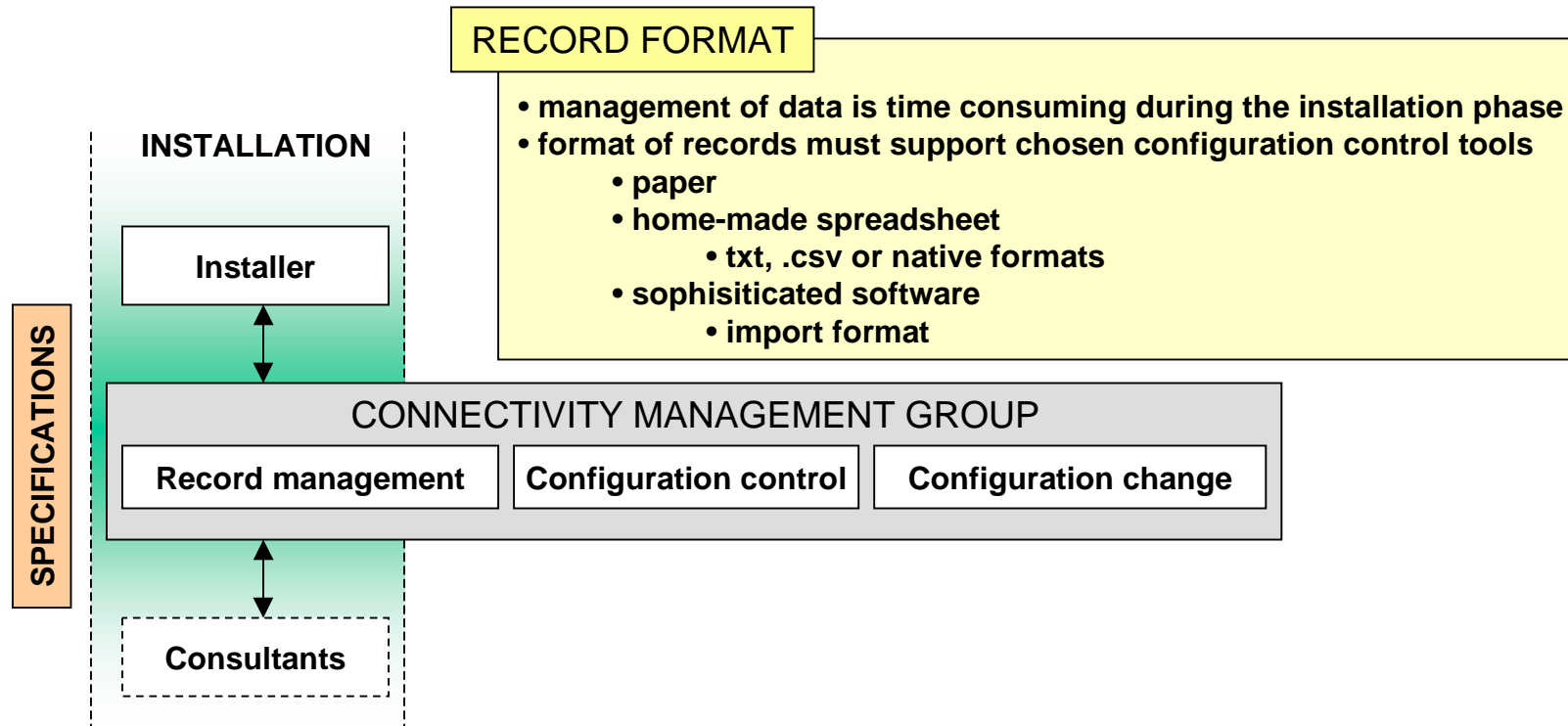

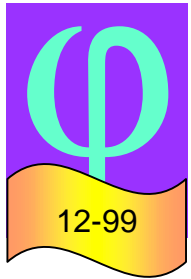

“MIND THE GAP” - A GUIDE TO THE MANAGEMENT OF CABLING PERFORMANCE

Procedures

THE USER MANUAL

- *equipment selection (EMC)*
- channel components
 - **where to use**
 - **how to procure**
- moves, changes, new lines
 - **how to order**
 - **how to implement**
- how to work outside the system
 - **inspection routines**
- *how to react in an emergency*
 - **re-routeing**

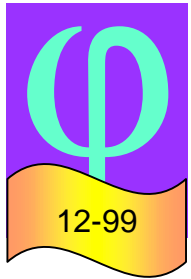

“MIND THE GAP” - A GUIDE TO THE MANAGEMENT OF CABLING PERFORMANCE

Procurement

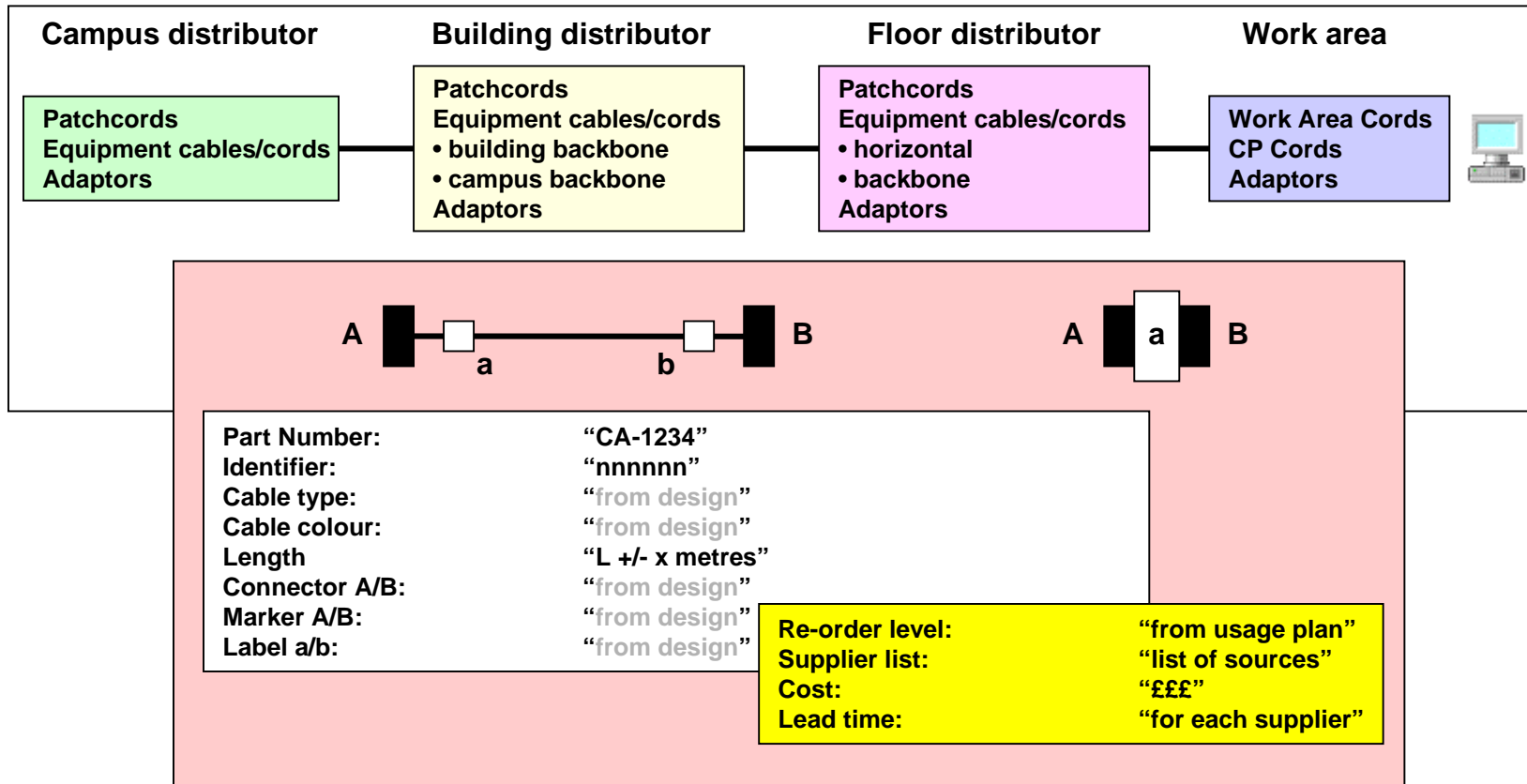

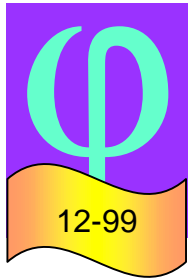

"MIND THE GAP" - A GUIDE TO THE MANAGEMENT OF CABLING PERFORMANCE

Configuration control

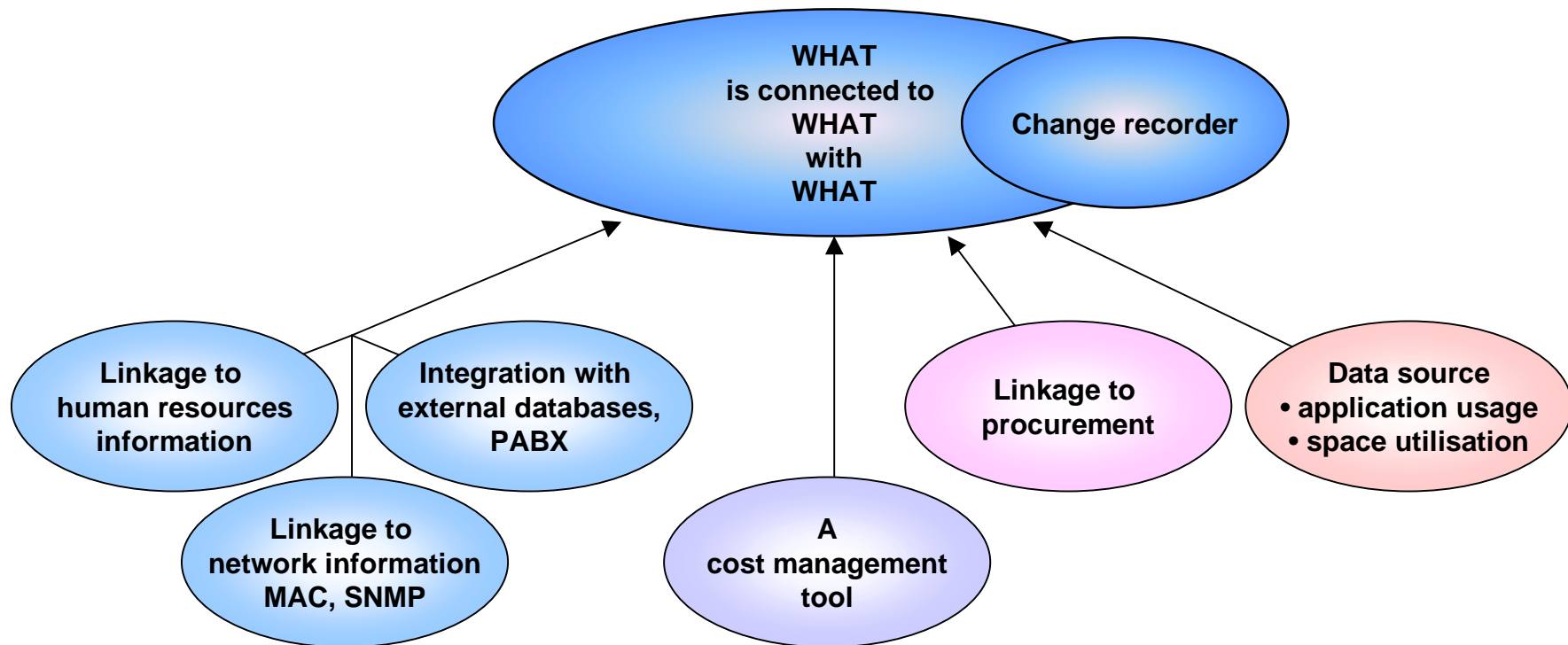

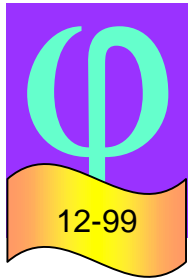

Change procedures

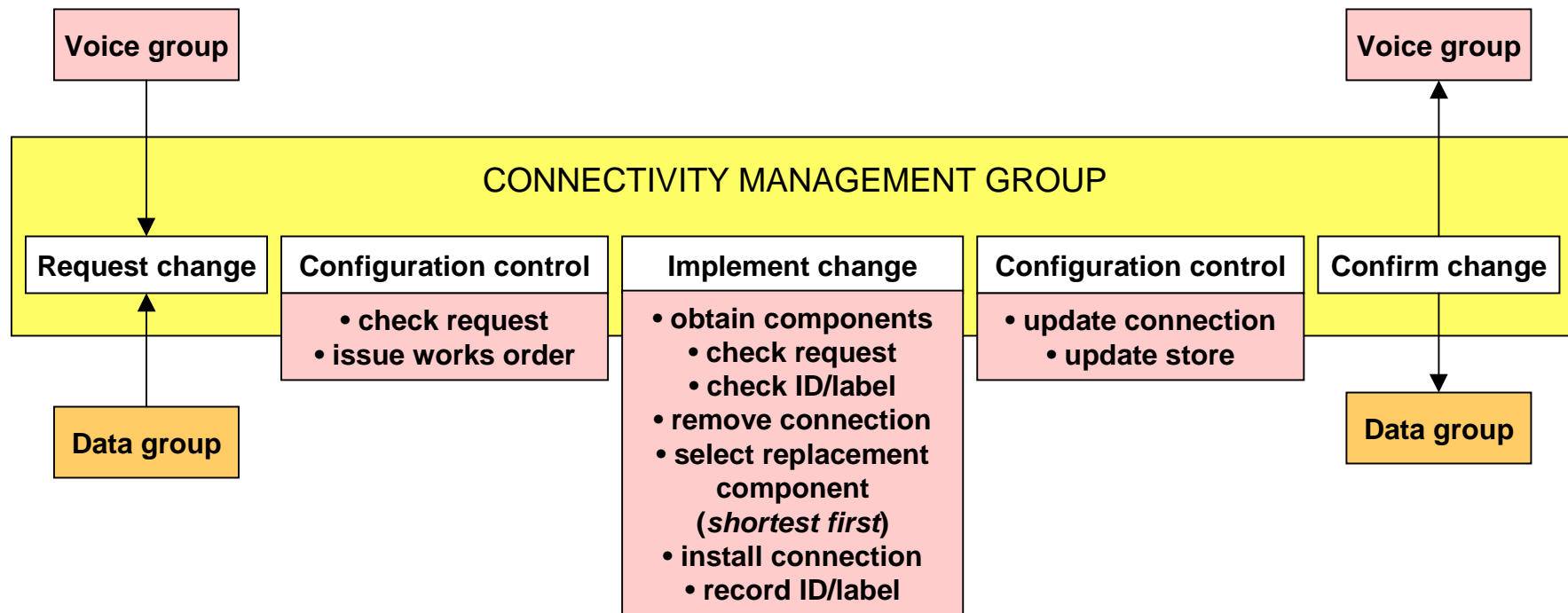

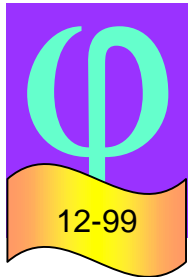

Escape procedures

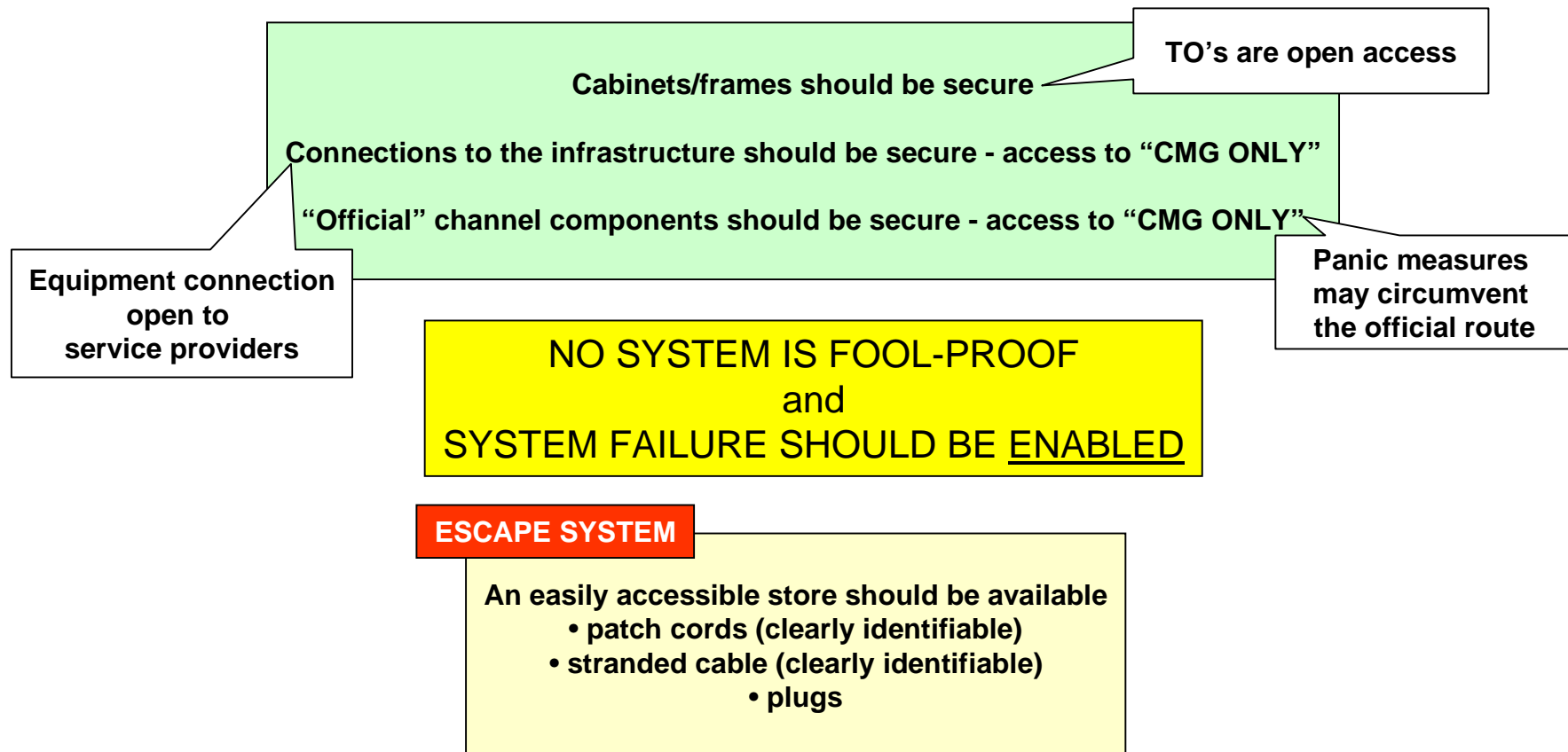

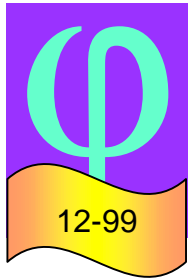

Inspection systems

LABELLING

- useful for detailed checking
 - identification
 - confirmation of location
- not a means of visual inspection

MARKING

- by means of coloured labels, boots or cables
- a means of visual inspection

INSPECTION SYSTEMS

Regular visual inspection of cabinets/frames and work areas should be introduced as part of operating procedures

HOW?

- marking of channel components
- open design of cabinet/frame

WHY?

- to highlight rogue activity
- to locate "escape-system works"
- to plan replacement works

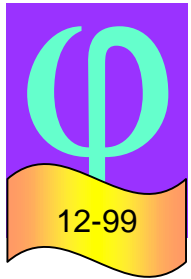

"MIND THE GAP" - A GUIDE TO THE MANAGEMENT OF CABLING PERFORMANCE

Agenda

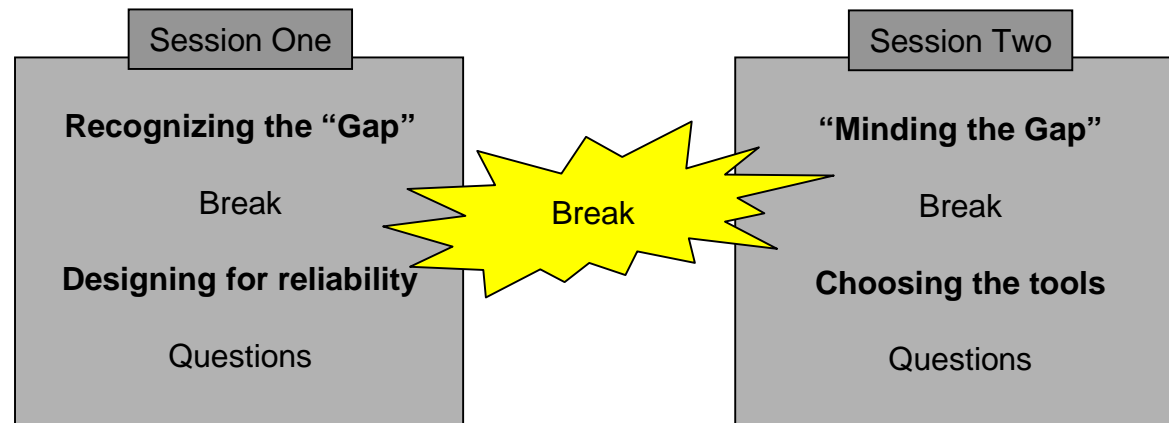

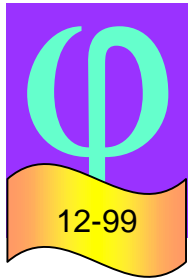

"MIND THE GAP" - A GUIDE TO THE MANAGEMENT OF CABLING PERFORMANCE

Agenda

The Connectivity Management Group (CMG)

- managing the CMG
 - buy-in to the CMG
 - education
- ### Systems
- configuration control tool
 - procedures
 - selection
 - standards and dedicated software
- ### Cost Controls

Session Two

"Minding the Gap"

Break

Choosing the tools

Questions

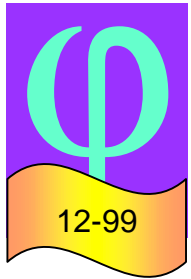

“MIND THE GAP” - A GUIDE TO THE MANAGEMENT OF CABLING PERFORMANCE

Managing the CMG

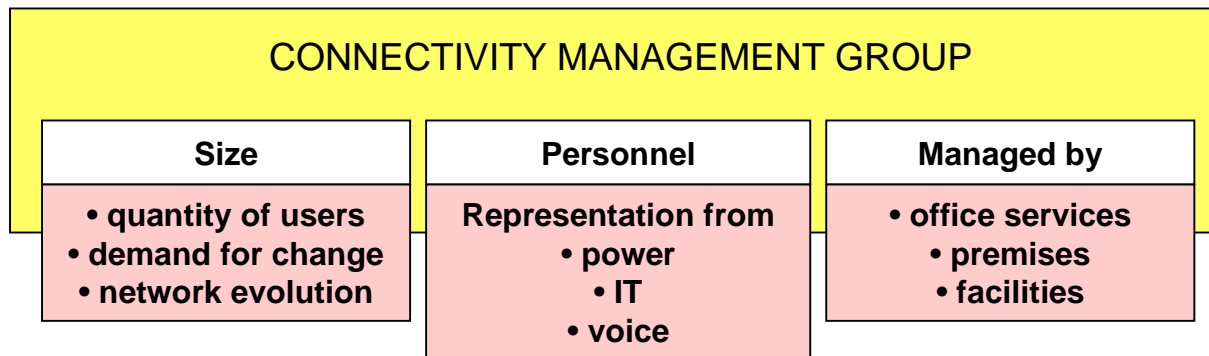
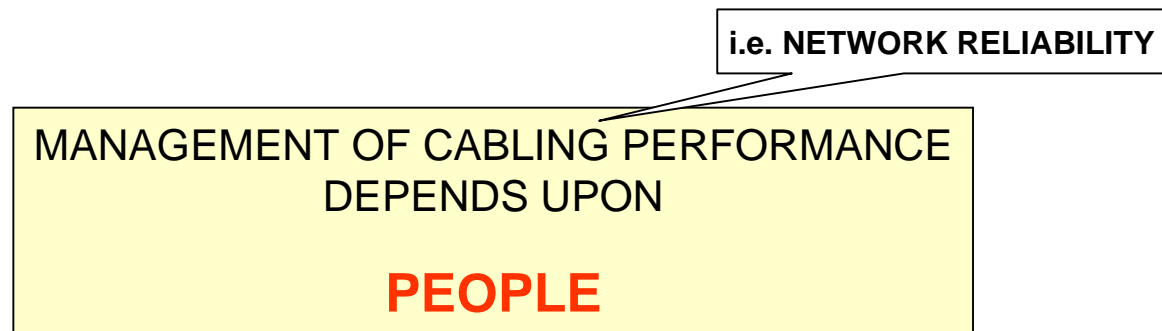

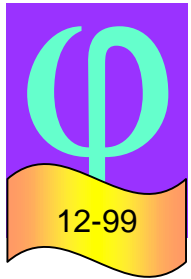

“MIND THE GAP” - A GUIDE TO THE MANAGEMENT OF CABLING PERFORMANCE

Buy-in to the CMG

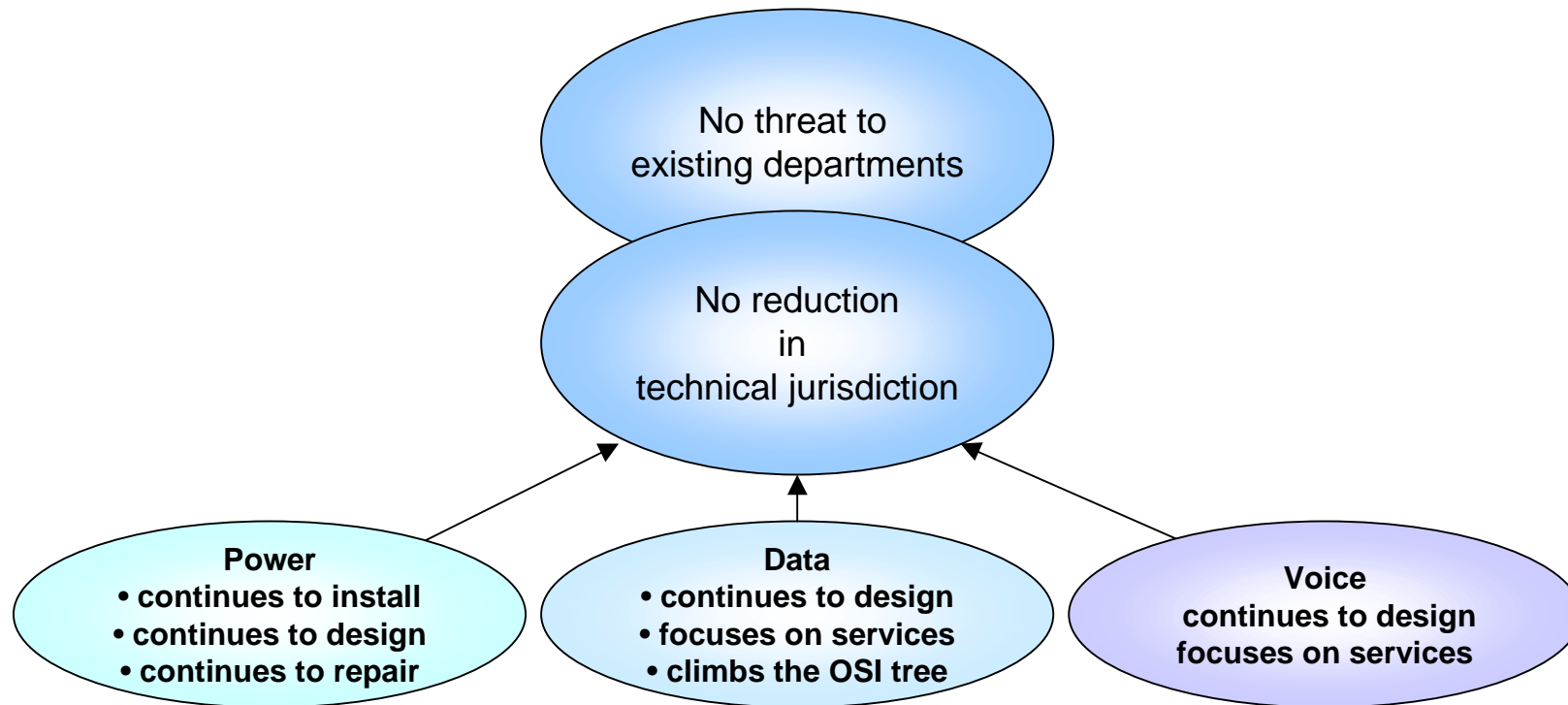

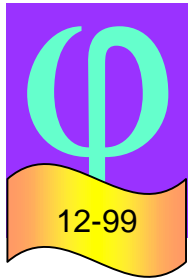

“MIND THE GAP” - A GUIDE TO THE MANAGEMENT OF CABLING PERFORMANCE

Education: the process

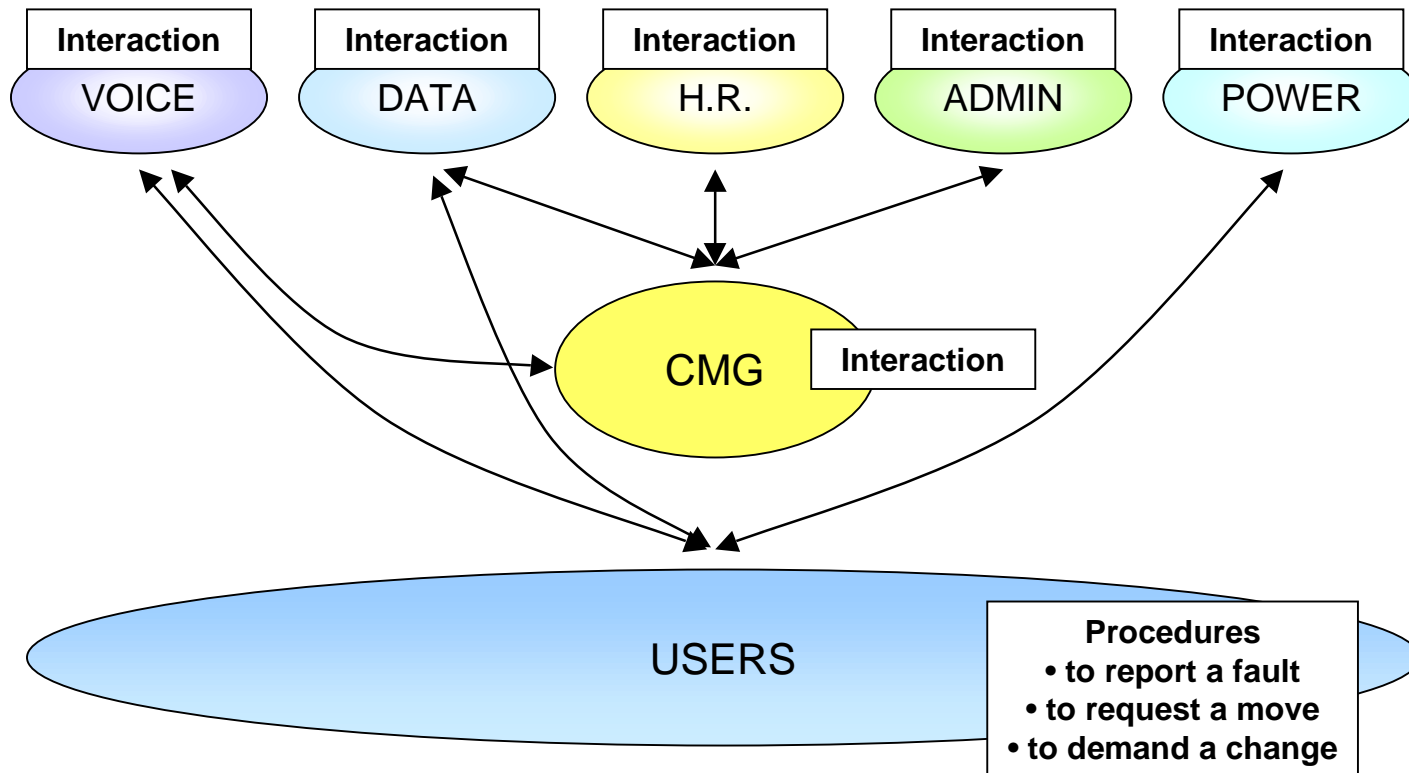

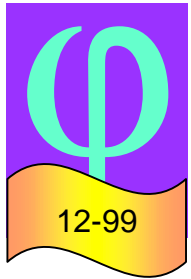

"MIND THE GAP" - A GUIDE TO THE MANAGEMENT OF CABLING PERFORMANCE

Education: the technology

RING-FENCED CONNECTIVITY

WHY?

- Training for:
- CMG line managers
 - peer groups
 - board directors

HOW?

- Training for:
- CMG engineers

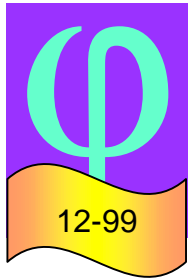

“MIND THE GAP” - A GUIDE TO THE MANAGEMENT OF CABLING PERFORMANCE

Systems

i.e. NETWORK RELIABILITY

MANAGEMENT OF CABLING PERFORMANCE
DEPENDS UPON
PEOPLE
FOLLOWING
SYSTEMS

PROCEDURES

CONFIGURATION CONTROL TOOL

Complexity	Type	Function
<ul style="list-style-type: none">• quantity of users• network supported• CMG personnel	<ul style="list-style-type: none">• paper• standard software• dedicated software	<ul style="list-style-type: none">• scope• integration

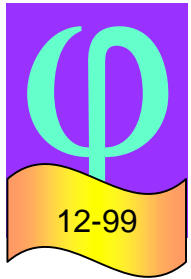

"MIND THE GAP" - A GUIDE TO THE MANAGEMENT OF CABLING PERFORMANCE

Procedures

- format
 - written
 - formal
 - change control
- covering
 - interactions
 - tasks
 - escape routes
 - inspections
- NOT
 - word of mouth
 - user dependent

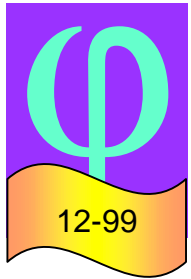

"MIND THE GAP" - A GUIDE TO THE MANAGEMENT OF CABLING PERFORMANCE

Configuration control tool

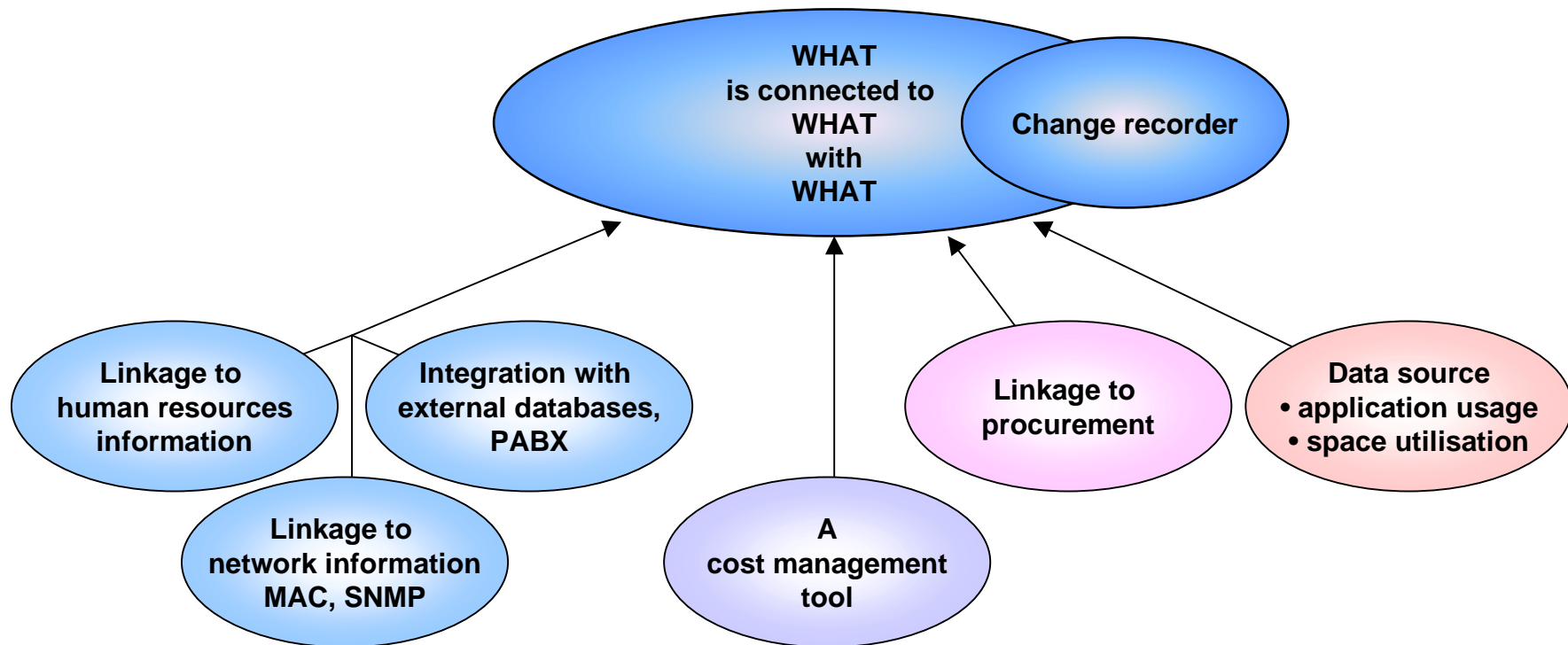

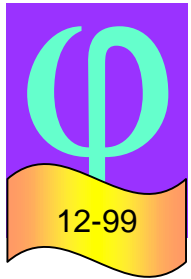

Tool selection

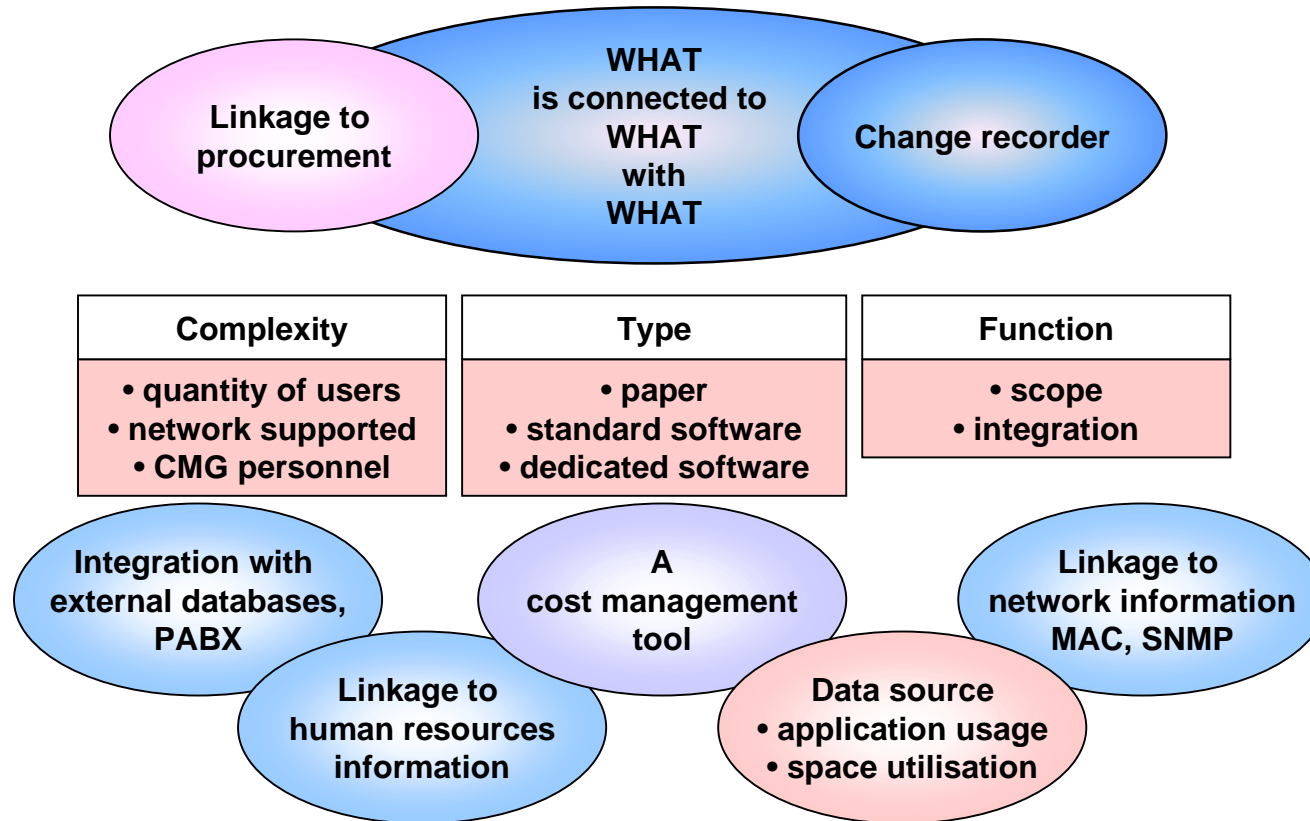

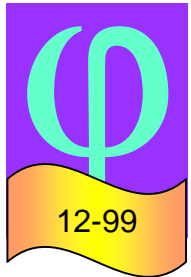

"MIND THE GAP" - A GUIDE TO THE MANAGEMENT OF CABLING PERFORMANCE

Tool options

Systems are people-based

- people using control tools
- control tools must deliver valid information

Tool selection

- support for rapid change
- volume analysis (change predictions)
- who will manage?
- when will they manage?

Paper records

- prone to human error
- contains no error checking
- deteriorates over time

Standard software

- replacement for paper
 - same faults
- false sense of security
- "re-invented wheels"

Specialist cable management software

- relational information
- circuit and connection display
- storage of associated information
- speed

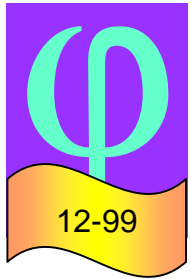

"MIND THE GAP" - A GUIDE TO THE MANAGEMENT OF CABLING PERFORMANCE

Software: standard - dedicated?

STANDARD SOFTWARE

Low capital cost: Typically EXCEL spreadsheet

- **limited in functionality**
- **low confidence levels**
 - **prone to error**
 - **no error checking**
- **limited scope for work order/report generation**
- **rarely good enough for exporting to sophisticated tools**

- **each one tailored to specific building**

DEDICATED SOFTWARE

High capital cost

- **designed to manage cabling**
- **error checking**
- **produces works orders**
- **highly configurable**

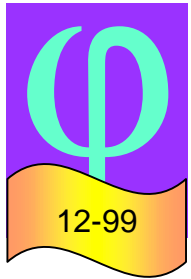

"MIND THE GAP" - A GUIDE TO THE MANAGEMENT OF CABLING PERFORMANCE

Generic spreadsheet software

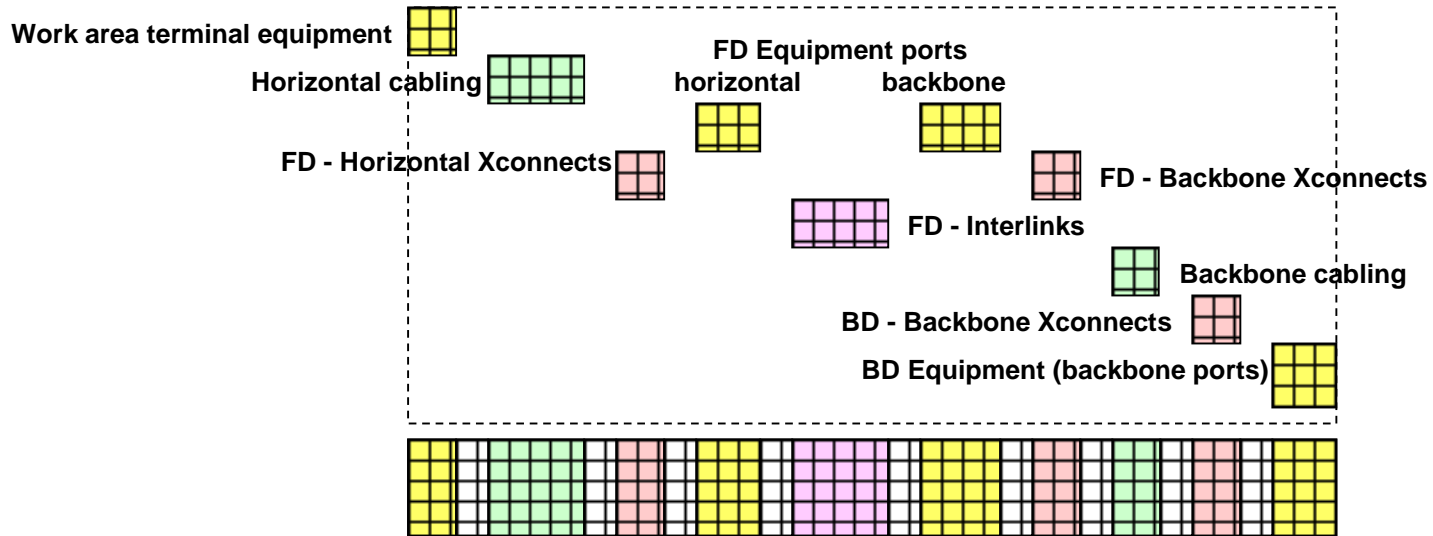

Drag and drop to create channels using patchcords/equipment cables

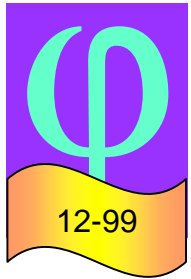

“MIND THE GAP” - A GUIDE TO THE MANAGEMENT OF CABLING PERFORMANCE

Dedicated software - structures

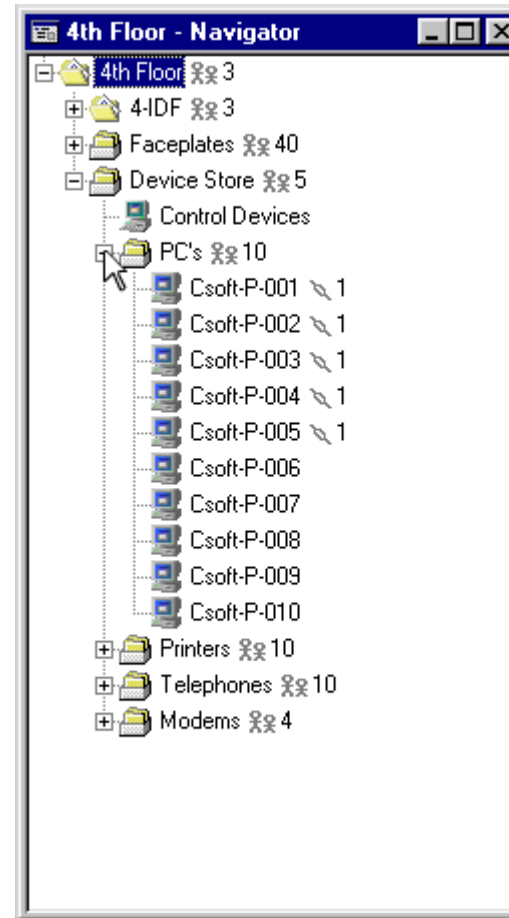
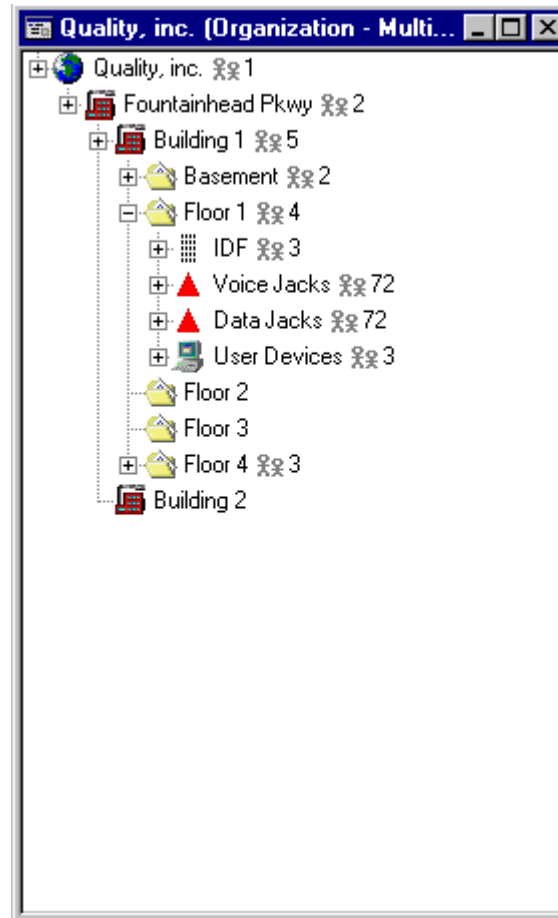

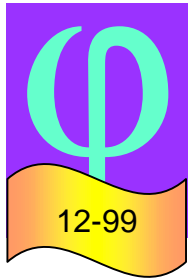

“MIND THE GAP” - A GUIDE TO THE MANAGEMENT OF CABLING PERFORMANCE

Dedicated software - graphics

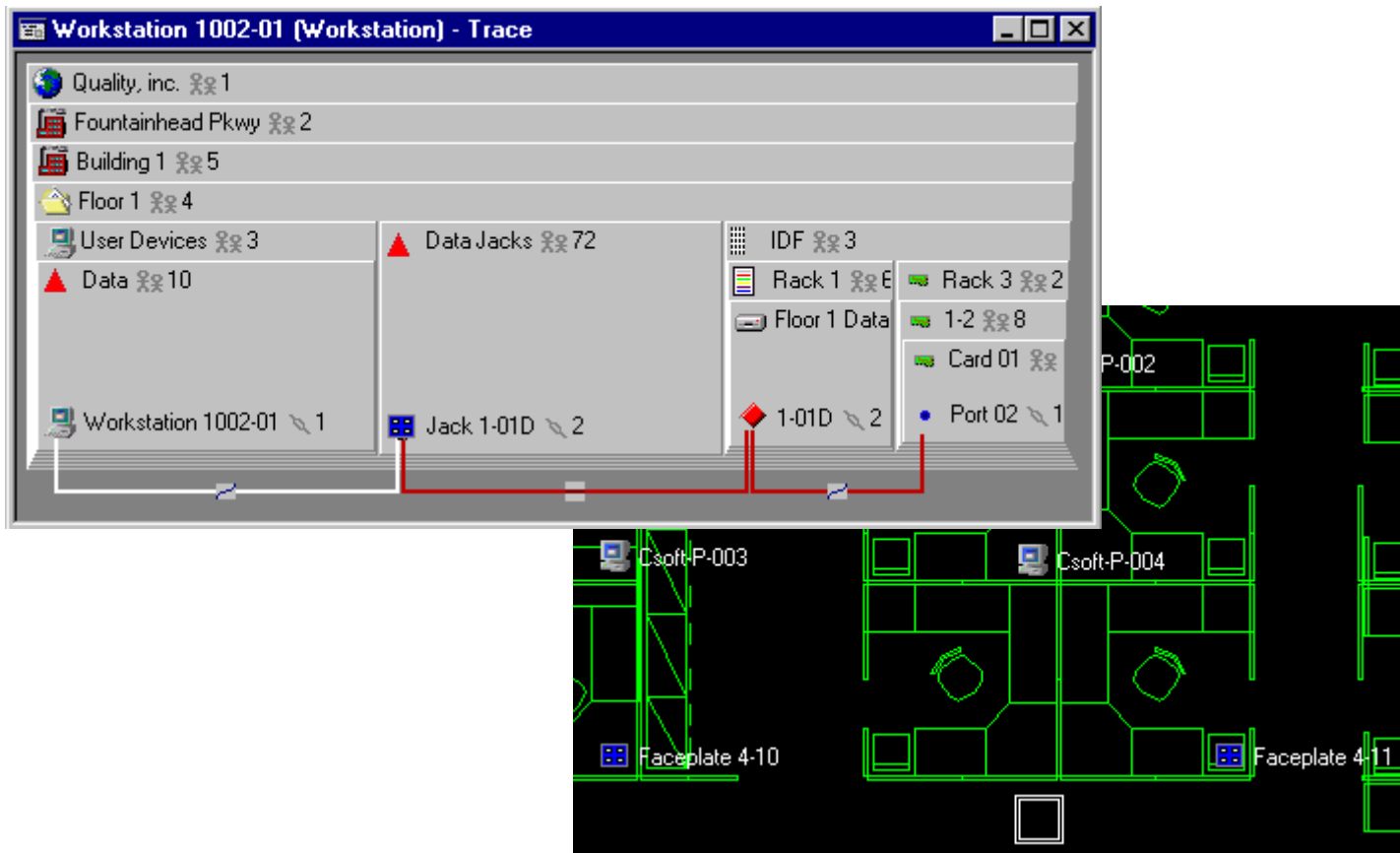

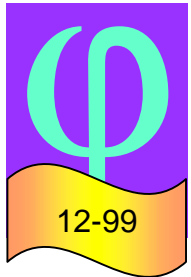

“MIND THE GAP” - A GUIDE TO THE MANAGEMENT OF CABLING PERFORMANCE

Dedicated software - layers

6 items - Browser

Item	PC Processor	IP Address	Disk Capacity (MB)	User Name	Department	ROOM #
Workstation 1002-01	Pentium II 450	109.24.55.200	1000.00	rperrin	Marketing	Room 01
Workstation 1002-02	Pentium II 333	109.24.55.201	2500.00	aaliabadi	Sales	Room 02

Dictionary for 'Workstation 1002-01'

IP Address: 132.18.55.195
Subnet Mask: 255.255.255.0

Software:
Windows 98
MS Word

Faceplate: No Faceplate/Floorbox found.
Jack: Jack 1-01D 2
Hub Port: Port 02 1
Hub Card: Card 01 24
Hub: 1-2 8
Server: Westminster 1
Server Card: NIC 100 Base T 1

User **Connectivity** Notes

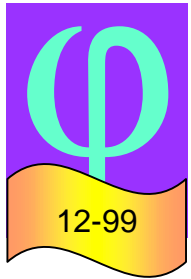

“MIND THE GAP” - A GUIDE TO THE MANAGEMENT OF CABLING PERFORMANCE

Dedicated software - integration

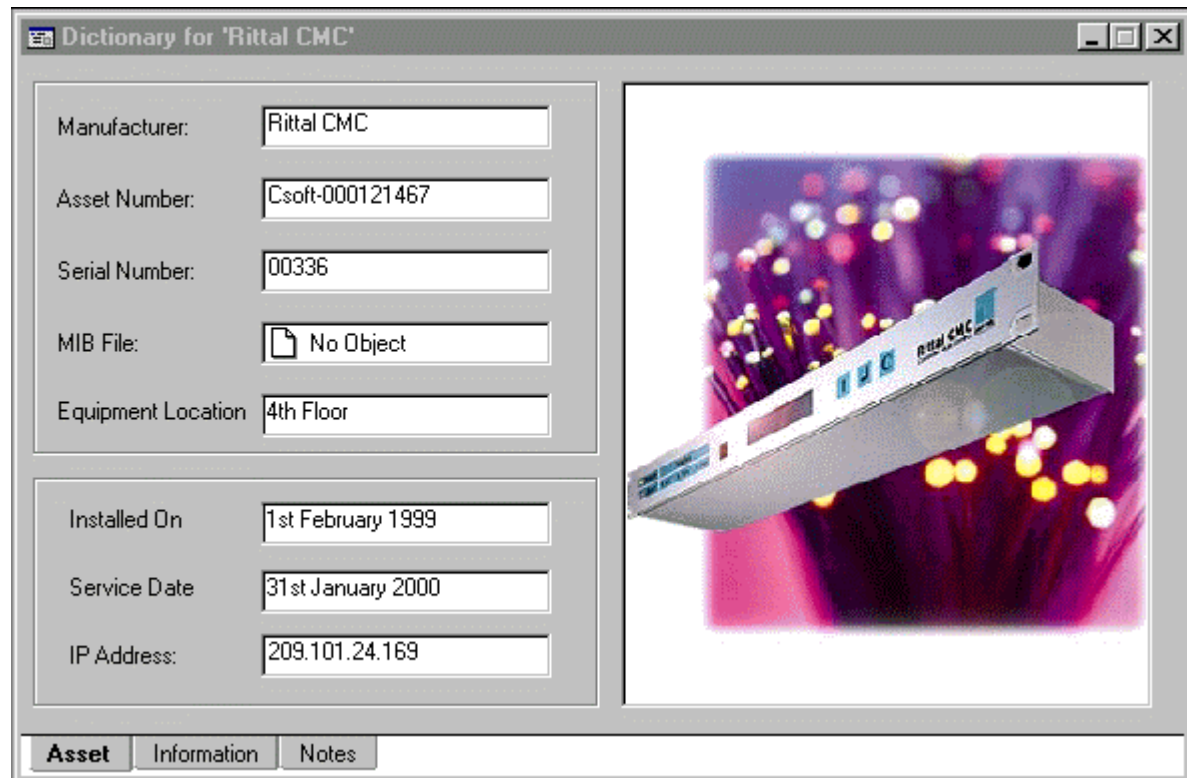
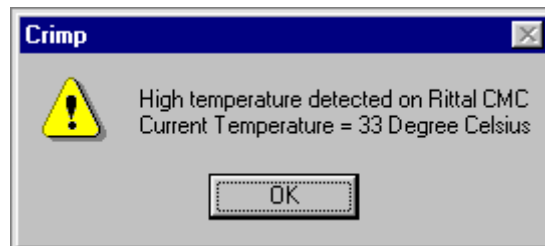

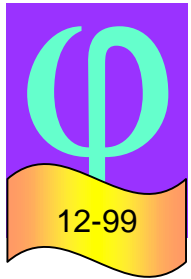

"MIND THE GAP" - A GUIDE TO THE MANAGEMENT OF CABLING PERFORMANCE

Software Selection

- database or CAD?
 - drawing based?
 - data based?
 - integration with other applications
 - flexibility
 - speed
 - operating system / hardware
- import tools
 - reduce setup cost
- data export
 - export allows freedom to migrate
- support of operating practices
 - flexibility
 - systems should not restrict operational activity

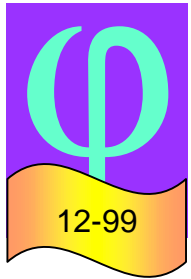

“MIND THE GAP” - A GUIDE TO THE MANAGEMENT OF CABLING PERFORMANCE

Cabling and cost controls

STRUCTURED CABLING RARELY DELIVERS PROMISED SAVINGS

Moves and changes are free

People can move - so they do, and more often

I've got a spare outlet, I'll have an extra phone

The number of serviced lines increases

This network's a little lethargic,
this cabling supports Gigabit Ethernet
-
so lets have it!!

Network engineers treat symptoms and do not cure the disease

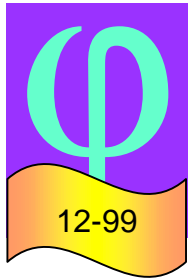

“MIND THE GAP” - A GUIDE TO THE MANAGEMENT OF CABLING PERFORMANCE

The internal IT market

Information Technology (IT)
• a profit base
• not an end in itself

Profit centres use IT
• IT departments do not
IT budgets should lie in profit centres
• not in IT departments

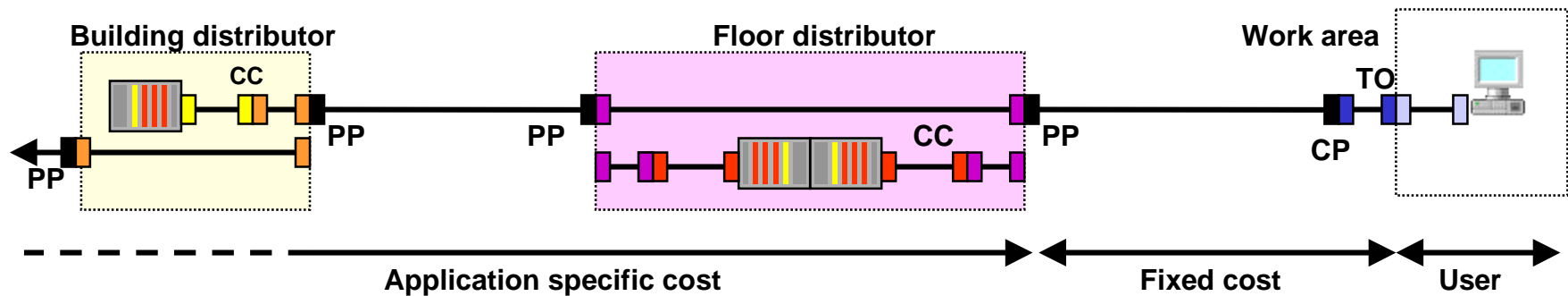

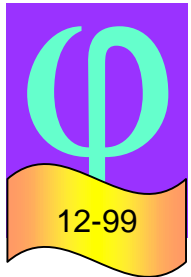

“MIND THE GAP” - A GUIDE TO THE MANAGEMENT OF CABLING PERFORMANCE

Departmental billing

COST ELEMENT	DESCRIPTION	BILLING	COST BASE
Line rental	Per TO outlet • application independent	Regular	Horizontal cabling (PP-TO)
Application rental	Application delivery cost at FD • application dependent • 100BASE-T >> voice	Regular	At the PP port (FD H) • backbone cabling • transmission equipment • physical infrastructure
Access charge	Application delivery cost at TO • application dependent • 100BASE-T >> voice	One-off	Work area costs • NIC • work area cord • adapters etc.
Connection charge	Cost of channel creation or modification	Multiple • based upon action	Modular task cost • creation of works order • task • record update
Repair charge	Cost of work-area based fault correction	Multiple • user behaviour	

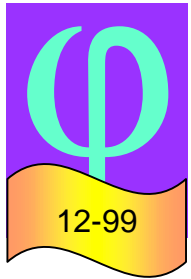

"MIND THE GAP" - A GUIDE TO THE MANAGEMENT OF CABLING PERFORMANCE

Conclusions - I

Installed cabling merely provides a foundation

Channel performance is fragile

Long-term network reliability requires channel management

MIND THE GAP

The higher performance the cabling, the greater the need for management

Investments in raw performance may backfire

Cabling models and templates are not so simple as we once thought

Design rules need to applied to the whole channel

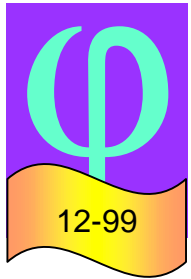

"MIND THE GAP" - A GUIDE TO THE MANAGEMENT OF CABLING PERFORMANCE

Conclusions - II

Management of channels requires new company structures

The concept of the Connectivity Management Group
integrating elements of data, voice and power is key
to channel management

The structure and selection of an administration system
is the most critical long term decision

Agreeing the management systems and the tools
should be the first step (and not the last) in the design process

Configuration control can provide significant additional management benefits

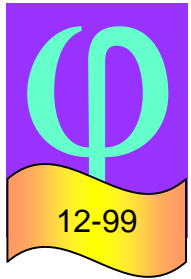

"MIND THE GAP" - A GUIDE TO THE MANAGEMENT OF CABLING PERFORMANCE

Agenda

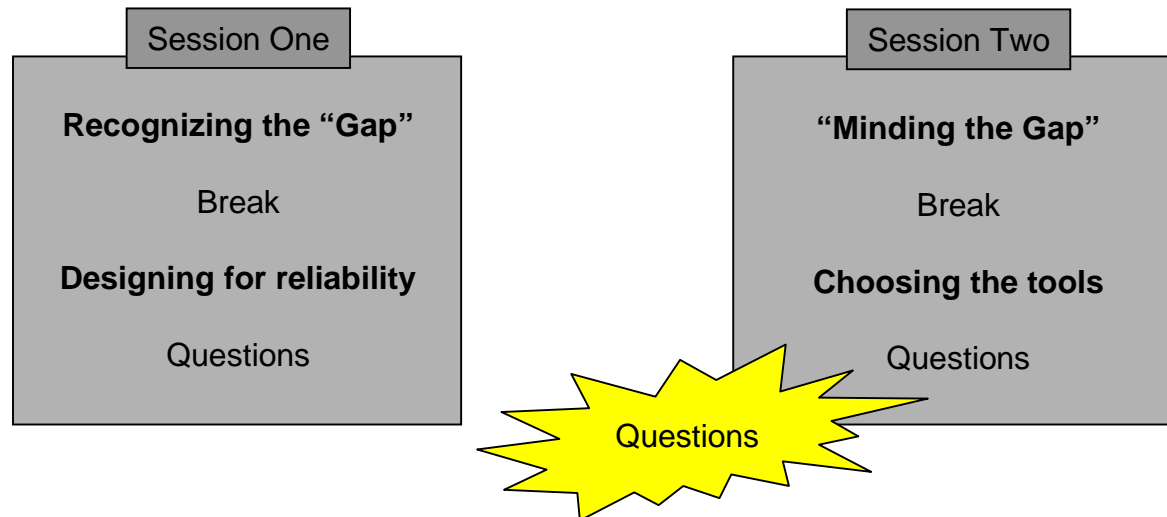

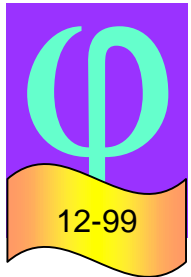

"MIND THE GAP" - A GUIDE TO THE MANAGEMENT OF CABLING PERFORMANCE

The End

- full colour copy of presentation
 - www.it-cabling.com/gendocs/gap.pdf

Mike.Gilmore@BTInternet.com
Tel/Fax:+44 (0) 113 232 3721

- the next MELTING POT seminars are on
 - 23rd March 2000
 - 28th March 2000

Mike.Gilmore@BTInternet.com
Tel/Fax:+44 (0) 113 232 3721