

# I.T. CABLING TRENDS - UPDATE

prepared and delivered  
by



November 2000

# Mike Gilmore

Presentations 2000

Mike.Gilmore@BTInternet.com  
Senior Partner,  
The Cabling Partnership  
PO Box MT65  
LEEDS  
LS17 8YD  
UK  
Tel: +44 113 232 3721  
Fax: +44 113 232 3724

Training

Design and specification

Cabling and IT cost management

Project management

Audits and arbitration

Standards

## UK

- Fibreoptic Industry Association, Technical Director
  - BSI, Chairman, TCT7/-/1: IT Cabling
- Europe
- CENELEC, Convenor, TC215 WG1: IT Cabling

EN 50098-1: "ISDN Basic Access"  
EN 50098-2: "ISDN Primary Rate"  
EN 50173: "Generic - Design"  
EN 50174-1/2: "Installation"  
prEN 50346: "Testing of Installed Cabling"

## International

- ISO/IEC, Member, JTC1 SC25 WG3: Generic Cabling

ISO/IEC 11801: "Generic - Design"  
ISO/IEC 14763-1: "Administration"  
ISO/IEC TR14763-2: "Planning and Installation"  
ISO/IEC TR14763-3: "Testing Optical Cabling"  
and via IEC SC46A WG2  
IEC 61935: "Testing Copper Cabling"



# Current Standards Status

Presentations 2000

## EUROPE EN 50173

- EN 50173 (1995) + EN 50173 A1 (2000)

## INTERNATIONAL IS 11801

- IS 11801 (1995)
- IS 11801 (1995) + IS 11801 Ed.1 A.1 (1999)
- IS 11801 (1995) + IS 11801 Ed.1 A.2 (1999)  
all combined as
- IS 11801 Ed.1.2 (2000)

## UNITED STATES ANSI/TIA/EIA 568A

- ANSI/TIA/EIA 568A (1995) + TSB95 (2000)
- ANSI/TIA/EIA 568A (1995)
  - + Addendum 1 (1997)
  - + Addendum 2 (1998)
  - + Addendum 3 (1998)
  
  - + Addendum 5 (2000)

# Next Generation Standards Status

## EUROPE EN 50173 Ed.2 (2002)

- NC Committee Enquiry **NOW**
- 6MP begins May, 2001
- 3MV begins December, 2001
- publication Q1, 2002

## INTERNATIONAL IS 11801 Ed.2 (2002)

- CDV **NOW**
- DIS Q1, 2001
- FDIS Q4, 2001
- publication Q1, 2002

## UNITED STATES ANSI/TIA/EIA 568B

- 568B.1 General Requirements
  - Draft 8, March 2000
- 568B.2 Balanced Twisted-pair Cabling
  - Draft 6.0, March 2000
  - Addendum 1
    - Category 6
    - Draft 7 (08/2000)
- 568B.3 Optical Fibre Cabling

# Agenda

Presentations 2000

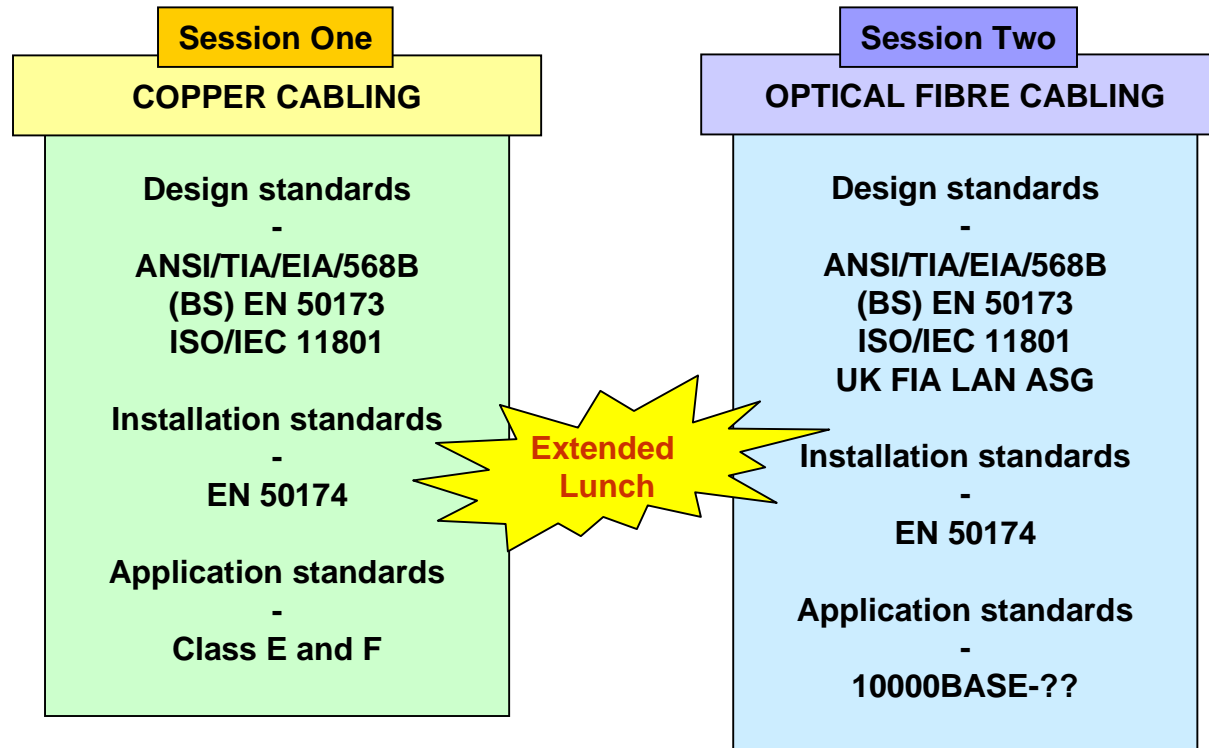

# Agenda

Presentations 2000

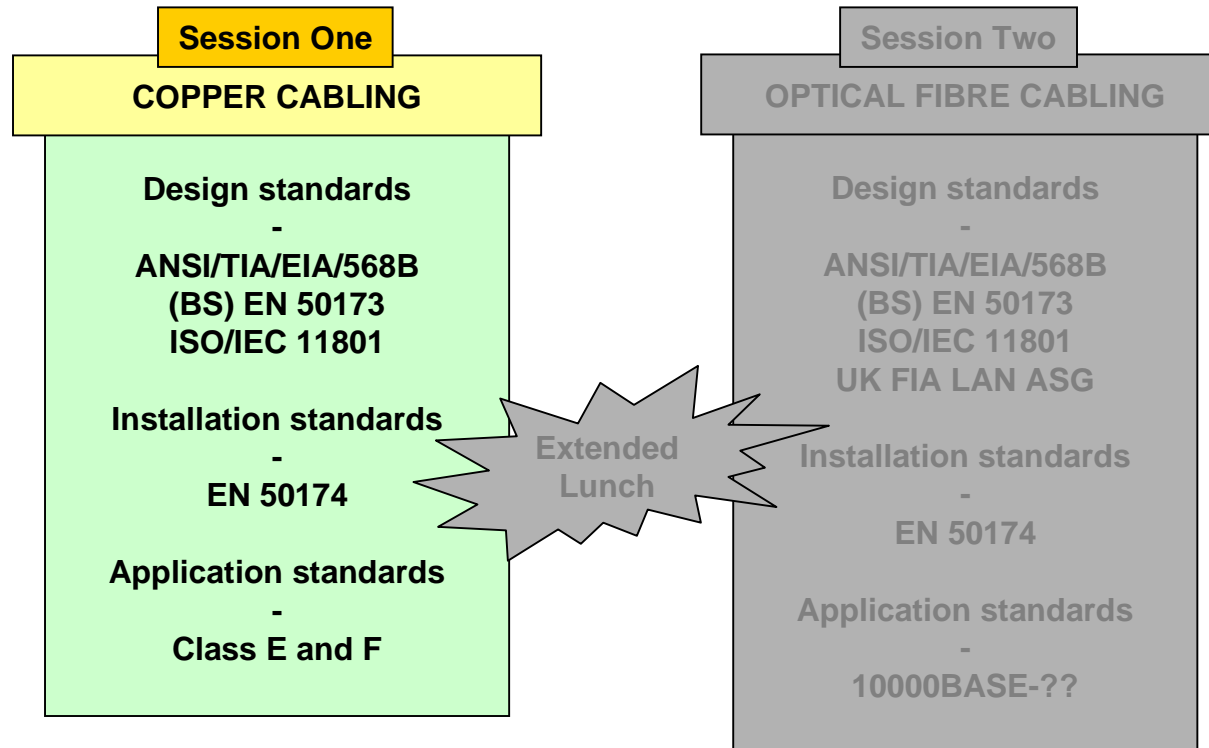

# Design Standards (1995)

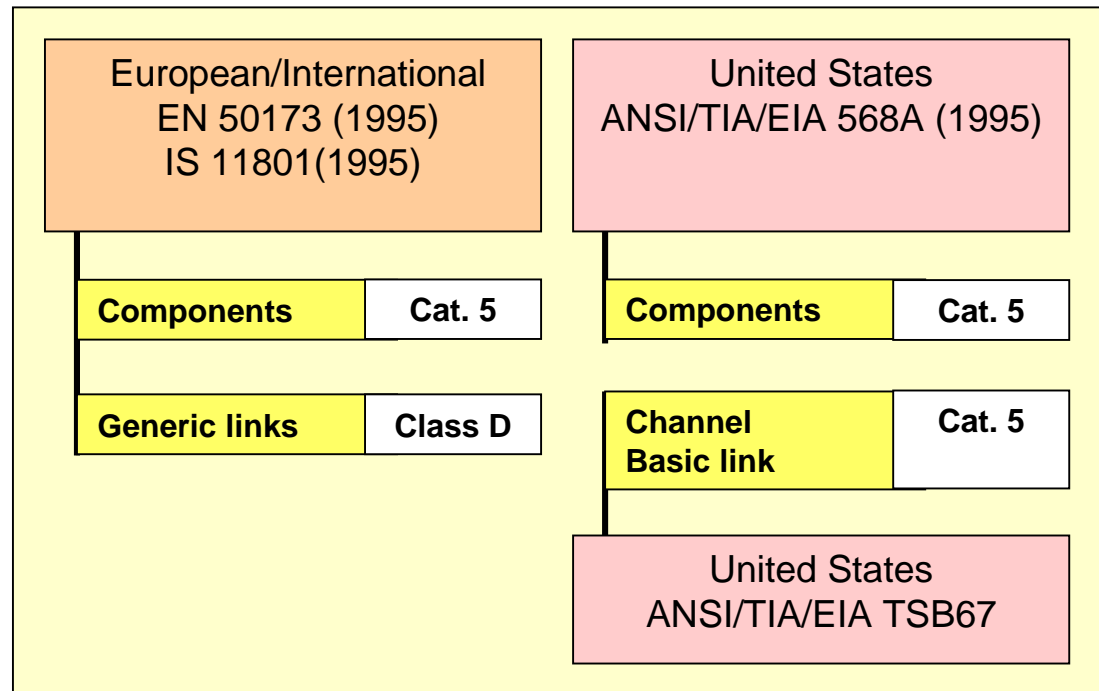

# Cat. 5 (1995) Channel

Presentations 2000

## Category 5 (1995) Channel

- based on Category 5 (1995) components
  - IS 11801, EN 50173 and 568A
- minimal specification
  - attenuation, NEXT
  - ACR specified by default
- design concept
  - simplex 2 pair transmission
  - 3 connectors
- risks
  - ATM155

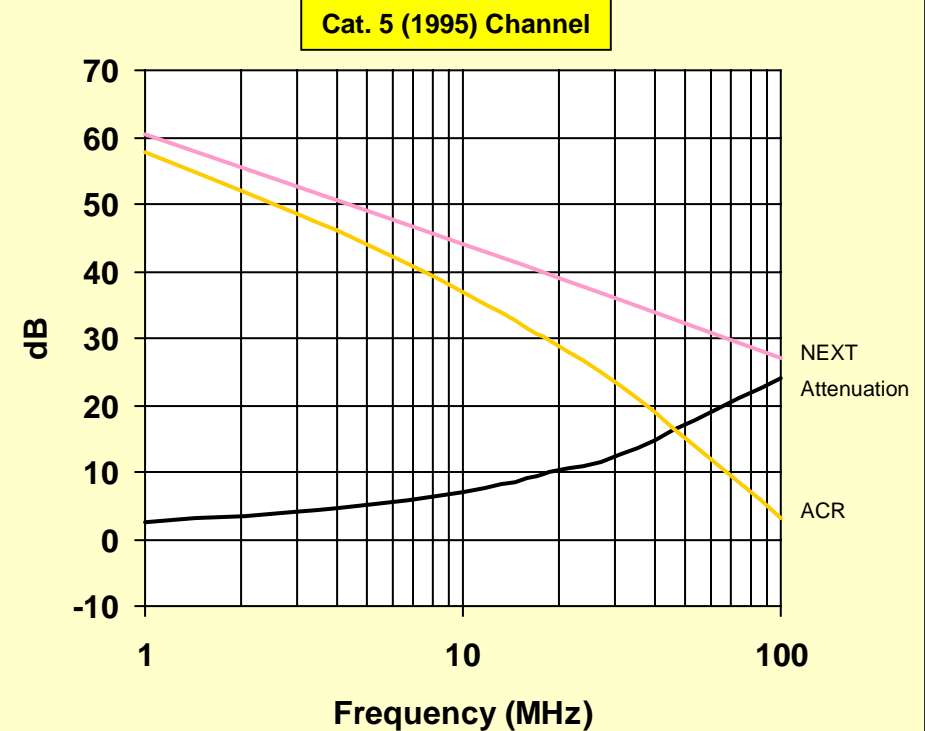
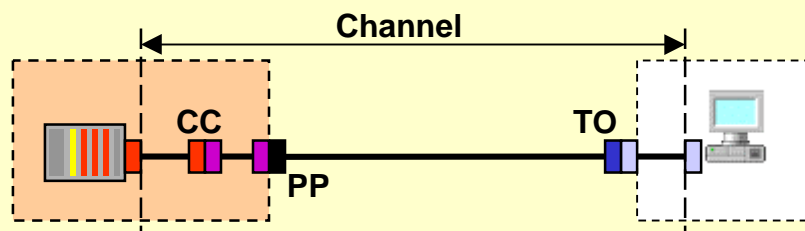

# Forces For Change

Presentations 2000

Cat. 5 (1995)

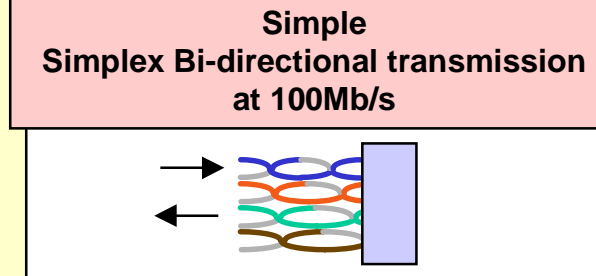
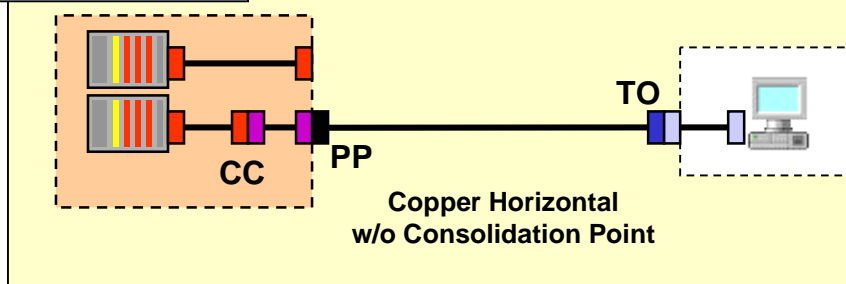

Cat. 5 (TSB95), Class D (2000)

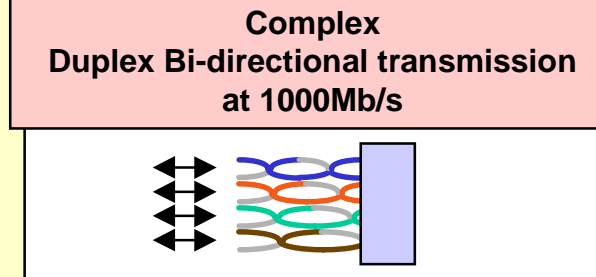
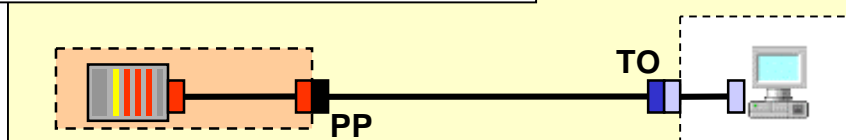

Cat. 5e and Class D (2002)

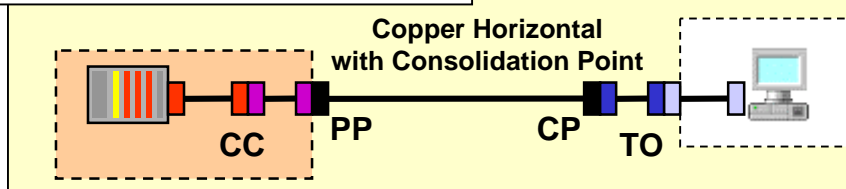

# Channels and Links

Presentations 2000

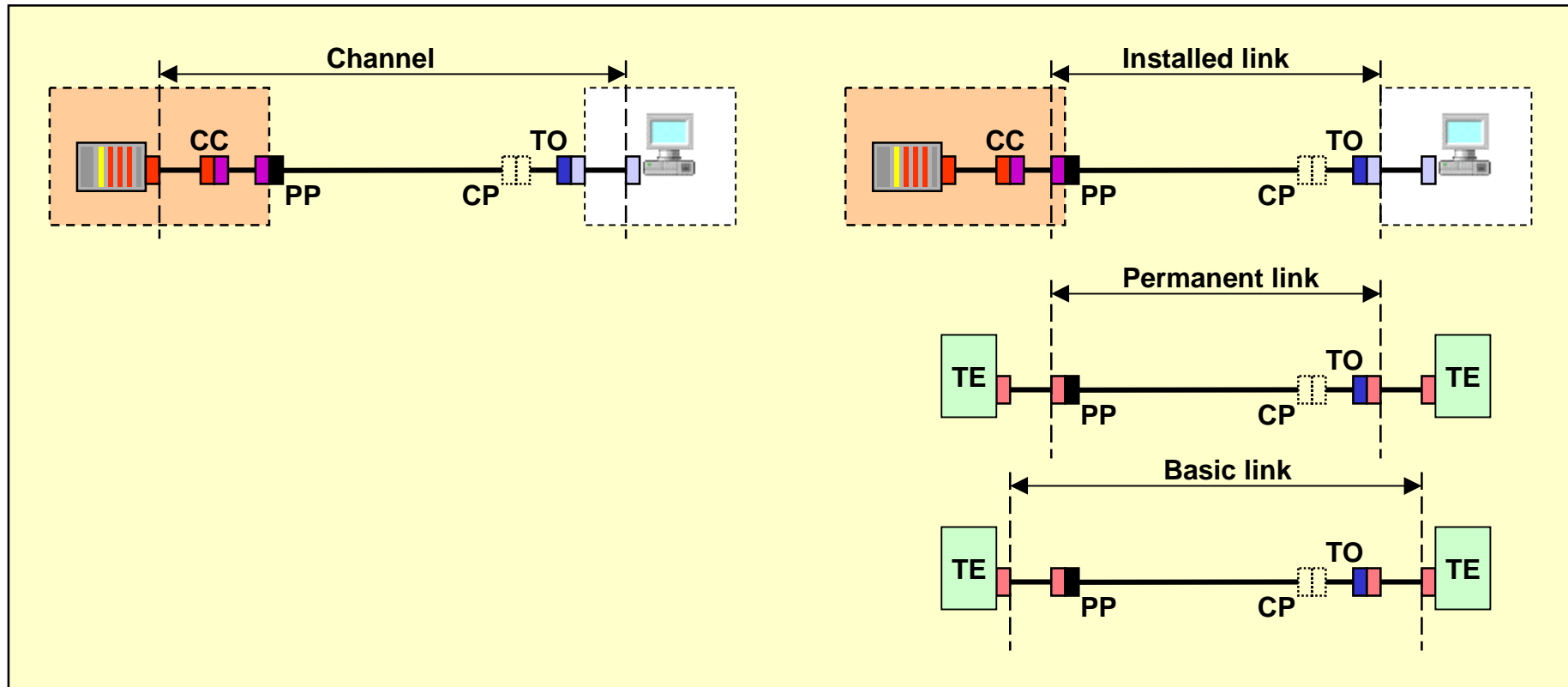

# Design Standards (2000)

Presentations 2000

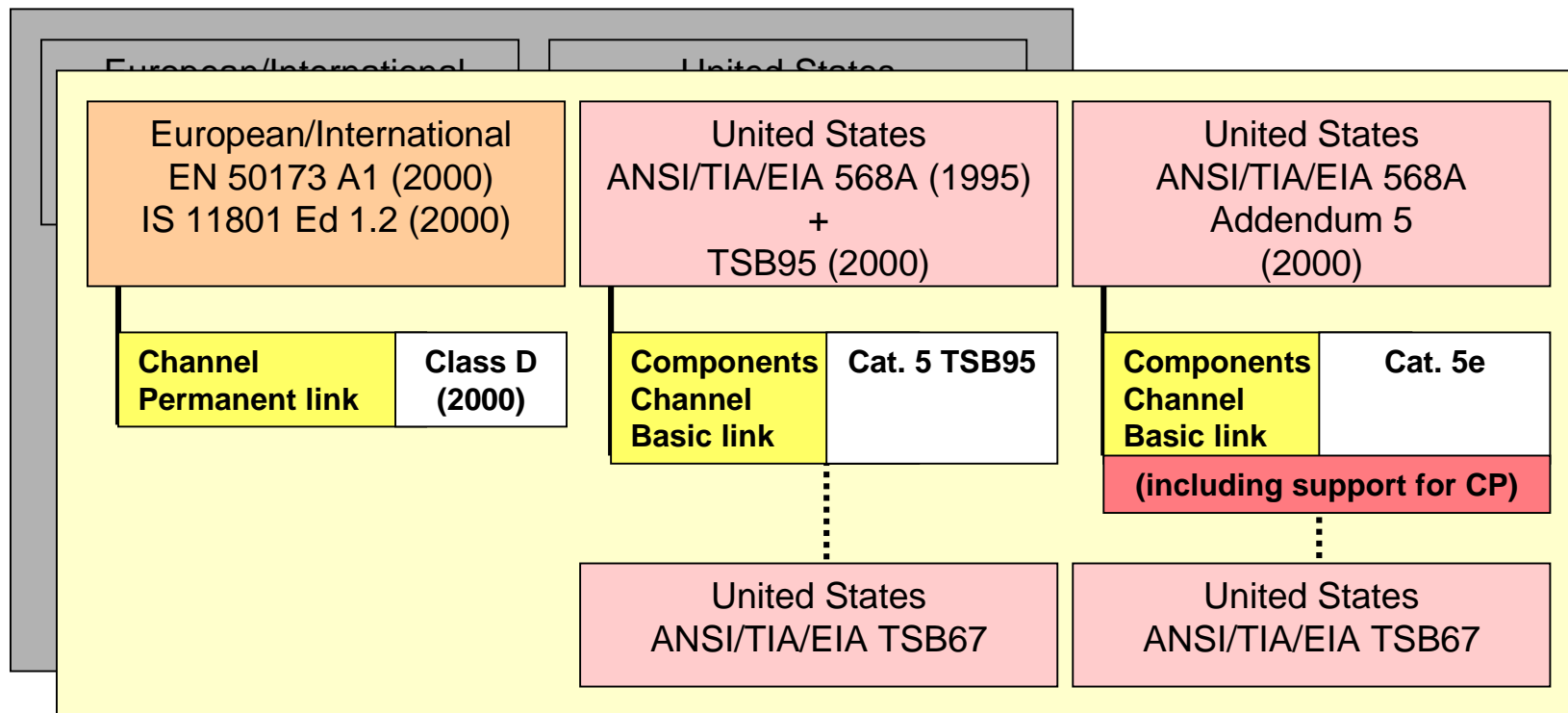

# Cat. 5e Channel

Presentations 2000

## Cat. 5e Channel

- based on Cat. 5e components
- performance upgrade from Cat. 5 (TSB95)
  - ~3dB NEXT, PSNEXT, ACR and PSACR
  - ~0.4dB ELFEXT
  - 2dB on return loss
- design concept
  - full duplex 4 pair transmission
  - 4 connectors
  - 1000BASE-T support with margin
    - 2dB return loss

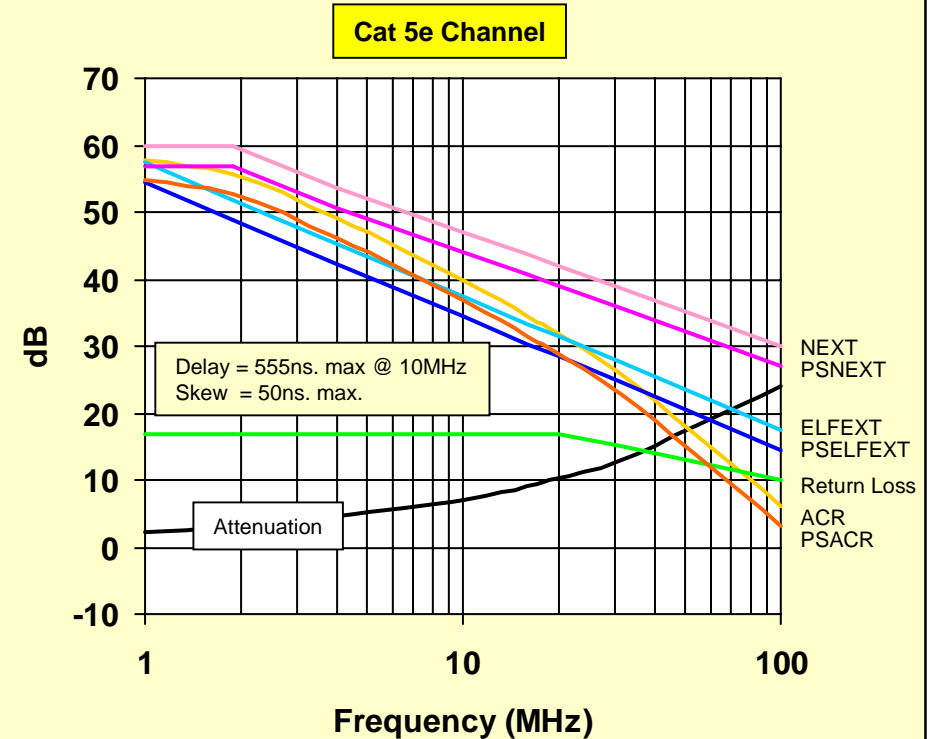
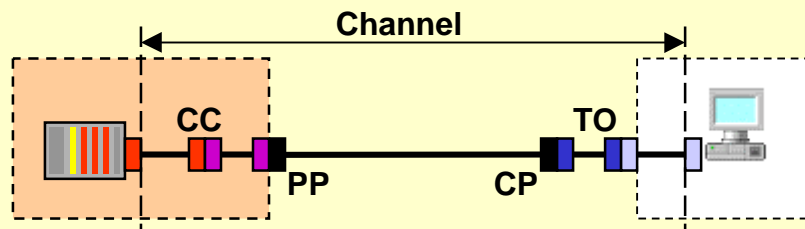

# Class D/Cat. 5e Installed Links

Presentations 2000

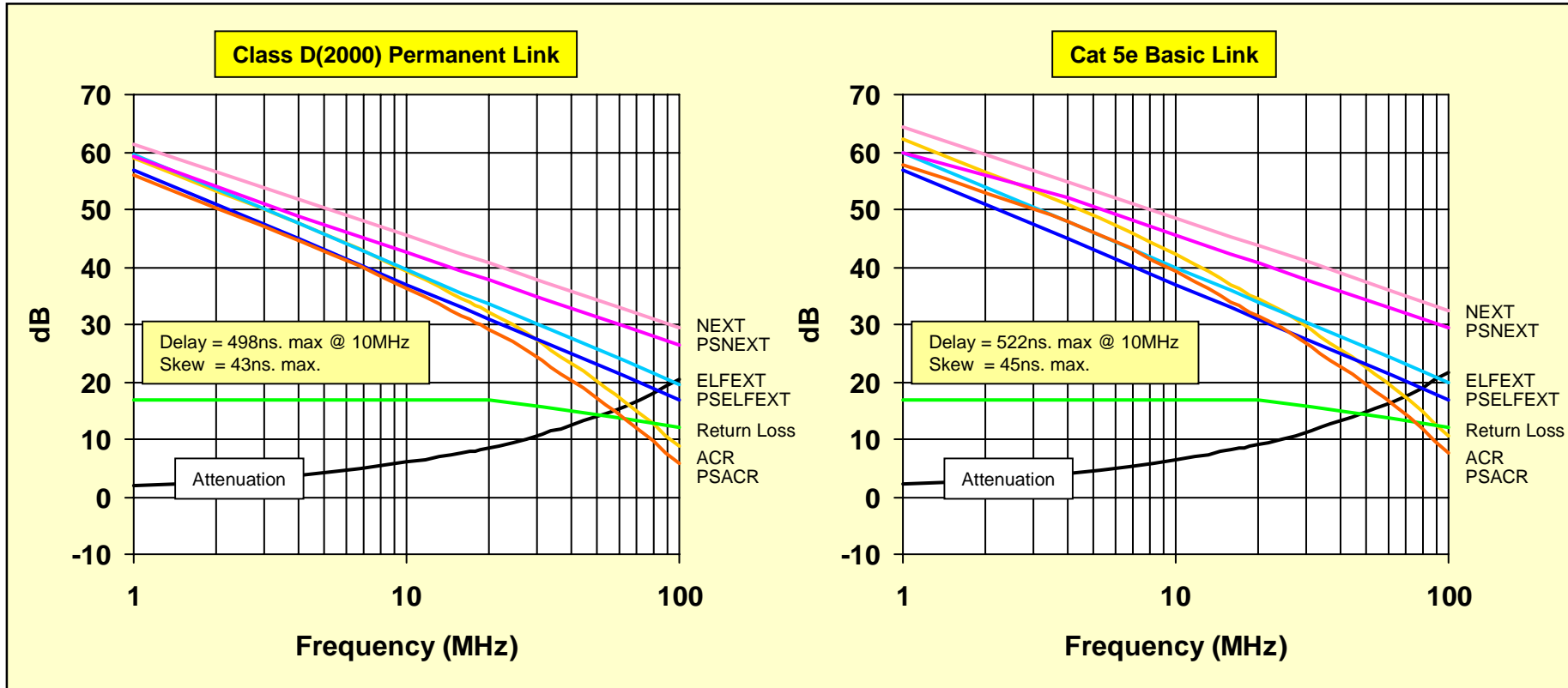

# Entry Level Cabling (2000)

## CATEGORY 5e

### Entry Level Technology

Channels in accordance with ANSI/TIA/EIA 568A Addendum 5

Basic links in accordance with ANSI/TIA/EIA 568A Addendum 5

Category 5e components allow installation of Class D (2000) channels and permanent links

Class D (2000) permanent link limits require a modification to the test equipment "calibration" procedure

- attenuation values below 4dB
  - information only
- return loss values where attenuation < 3dB
  - information only
- NEXT values where attenuation < 4dB
  - conform to ACR requirements
- PSNEXT values where attenuation < 4dB
  - conform to PSACR requirements

Not all test equipment enables all tests.  
Return loss (in particular) should be checked.

**WARNING**

# Next Generation Standards

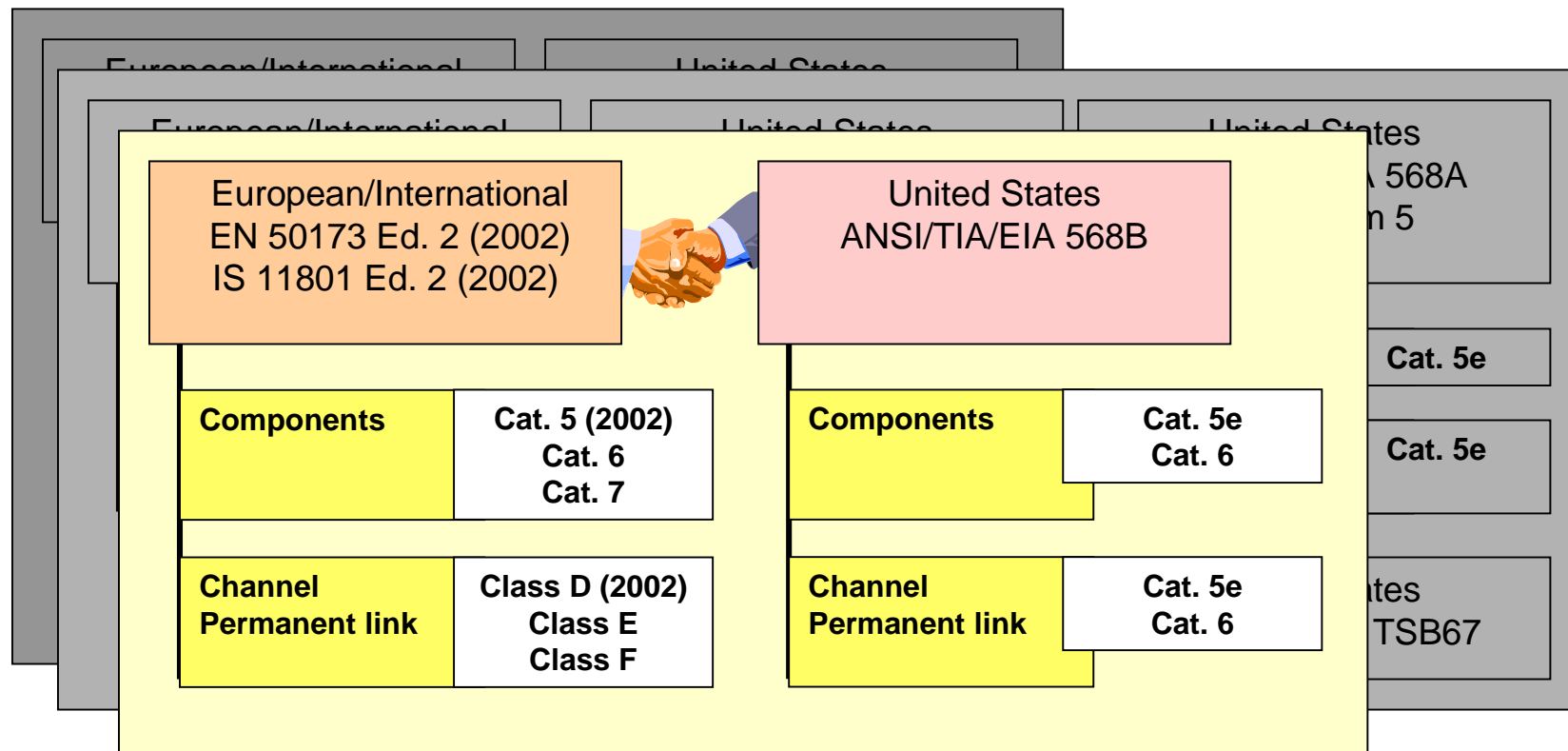

# Class D (2002) Channel Equations

| Parameter                   | Frequency           | Channel formulae  |
|-----------------------------|---------------------|---|
| Attenuation (dB max.)       | $1 \leq f \leq 100$ | $1.05 \times (1.9108Sf + 0.0222f + 0.2/Sf) + 4 \times 0.04Sf$   |
| NEXT (dB min.)              | $1 \leq f \leq 100$ | $-20 \log(10^{-0.05(65.3-15\log(f))} + 2 \times 10^{-0.05(83-20\log(f))})$ , 60 dB max.   |
| PSNEXT (dB min.)            | $1 \leq f \leq 100$ | $-20 \log(10^{-0.05(62.3-15\log(f))} + 2 \times 10^{-0.05(80-20\log(f))})$ , 57 dB max.   |
| ACR<br>(dB min.)            | $1 \leq f \leq 100$ | $-20 \log(10^{-0.05(65.3-15\log(f))} + 2 \times 10^{-0.05(83-20\log(f))}) -$<br>$(1.05 \times (1.9108Sf + 0.0222f + 0.2/Sf) + 4 \times 0.04Sf)$ |
| PSACR<br>(dB min.)          | $1 \leq f \leq 100$ | $-20 \log(10^{-0.05(62.3-15\log(f))} + 2 \times 10^{-0.05(80-20\log(f))}) -$<br>$(1.05 \times (1.9108Sf + 0.0222f + 0.2/Sf) + 4 \times 0.04Sf)$ |
| ELFEXT (dB min.)            | $1 \leq f \leq 100$ | $-20 \log(10^{-0.05(63.8-20\log(f))} + 4 \times 10^{-0.05(75.1-20\log(f))})$ , 60 dB max.   |
| PSELFEXT (dB min.)          | $1 \leq f \leq 100$ | $-20 \log(10^{-0.05(60.8-20\log(f))} + 4 \times 10^{-0.05(72.1-20\log(f))})$ , 57 dB max.   |
| Return loss (dB min.)       | $1 \leq f \leq 100$ | $30 - 10\log(f)$ , 17.0 dB max.   |
| Prop. Delay ( $\mu$ s max.) | $1 \leq f \leq 100$ | $0.534 + 0.036Sf + 4 \times 0.0025$   |
| Skew ( $\mu$ s max.)        | $1 \leq f \leq 100$ | $0.045 + 4 \times 0.0025 = 0.050$   |

# Class D (2002) Channel

Presentations 2000

## Class D (2002) Channel

- essentially identical to Cat. 5e channel
- PSACR = 0dB at 125MHz (derived)

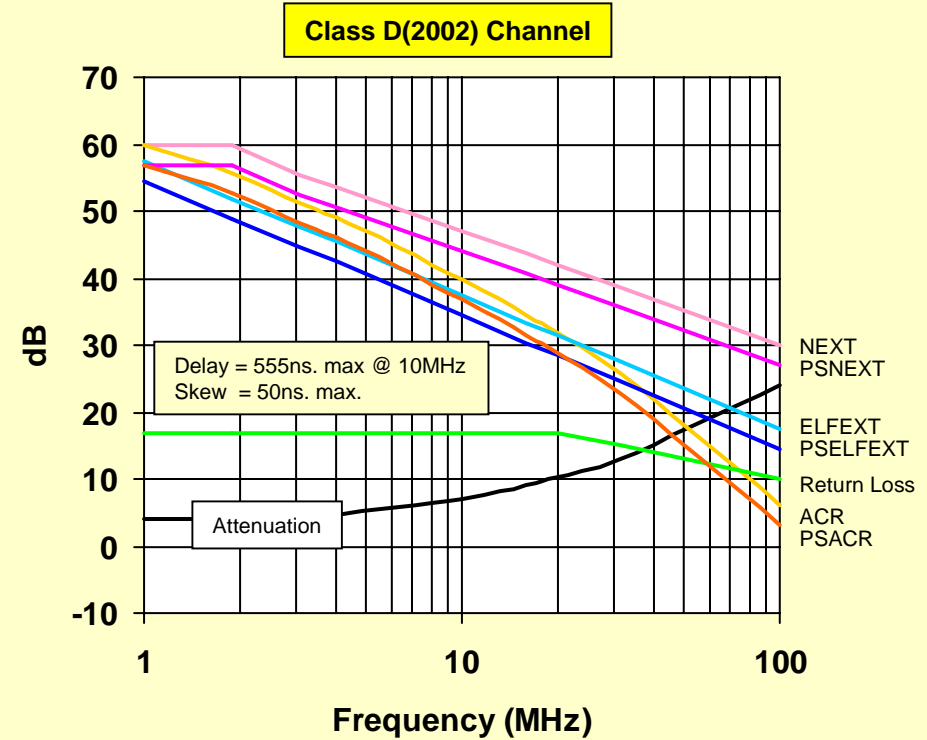
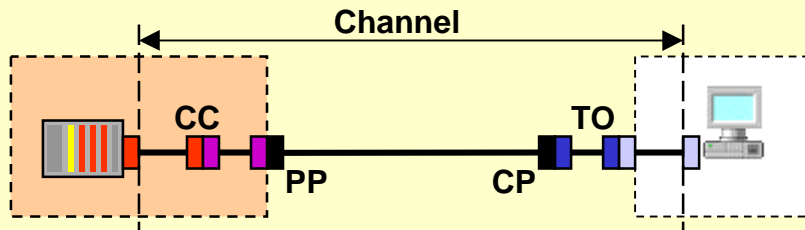

# Class E Channel Equations

Presentations 2000

| Parameter                   | Frequency                                  | Channel formulae   |
|-----------------------------|--|--|
| Attenuation (dB max.)       | $1 \leq f \leq 250$                        | $1.05 \times (1.82Sf+0.0169+0.25/Sf) + 4x0.02Sf$   |
| NEXT (dB min.)              | $1 \leq f \leq 250$                        | $-20 \log(10^{-0.05(74.3-15\log(f))} + 2x10^{-0.05(94-20\log(f))})$ , 65 dB max.                                       |
| PSNEXT (dB min.)            | $1 \leq f \leq 250$                        | $-20 \log(10^{-0.05(72.3-15\log(f))} + 2x10^{-0.05(90-20\log(f))})$ , 62 dB max.                                       |
| ACR<br>(dB min.)            | $1 \leq f \leq 250$                        | $-20 \log(10^{-0.05(74.3-15\log(f))} + 2x10^{-0.05(94-20\log(f))}) - (1.05 \times (1.82Sf+0.0169+0.25/Sf) + 4x0.02Sf)$ |
| PSACR<br>(dB min.)          | $1 \leq f \leq 250$                        | $-20 \log(10^{-0.05(72.3-15\log(f))} + 2x10^{-0.05(90-20\log(f))}) - (1.05 \times (1.82Sf+0.0169+0.25/Sf) + 4x0.02Sf)$ |
| ELFEXT (dB min.)            | $1 \leq f \leq 250$                        | $-20 \log(10^{-0.05(67.8-20\log(f))} + 4x10^{-0.05(83.1-20\log(f))})$ , 65 dB max.                                     |
| PSELFEXT (dB min.)          | $1 \leq f \leq 250$                        | $-20 \log(10^{-0.05(64.8-20\log(f))} + 4x10^{-0.05(80.1-20\log(f))})$ , 62 dB max.                                     |
| Return loss (dB min.)       | $1 \leq f \leq 40$<br>$40 \leq f \leq 250$ | $24-5\log(f)$ , 19.0 dB max.<br>$32-10\log(f)$   |
| Prop. Delay ( $\mu$ s max.) | $1 \leq f \leq 250$                        | $0.534 + 0.036Sf + 4x0.0025$   |
| Skew ( $\mu$ s max.)        | $1 \leq f \leq 250$                        | $0.045 + 4x0.0025 = 0.050$   |

# Class E Channel

Presentations 2000

## Class E Channel

- performance upgrade over Class D (2002)
  - 2.3dB@100MHz Attenuation (~10%)
  - 9.8dB NEXT, 10dB PSNEXT
  - 5.9dB ELFEXT, PSELFEXT
  - ~2dB return loss
- PSACR > 0dB at 200MHz
- specified up to 250MHz

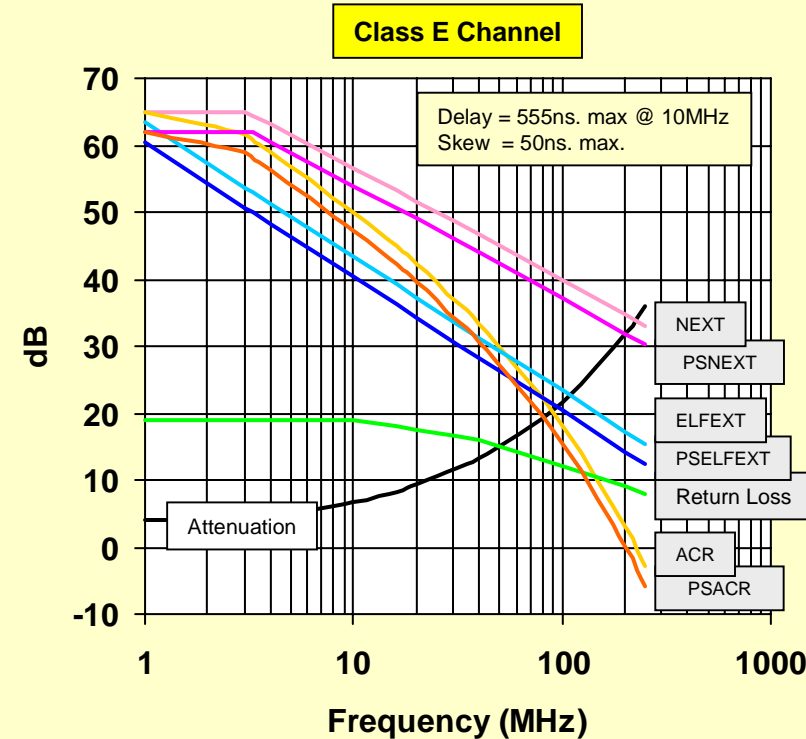
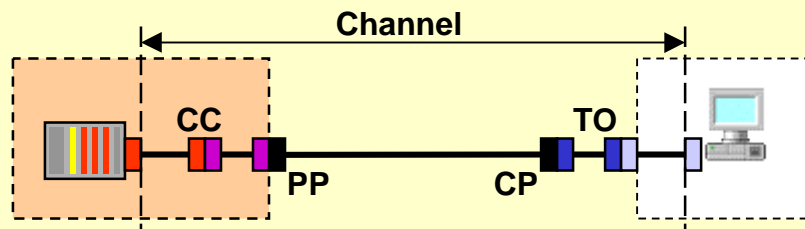

# Class F Channel Equations

Presentations 2000

| Parameter                   | Frequency                                  | Channel formulae  |
|-----------------------------|--|---|
| Attenuation (dB max.)       | $1 \leq f \leq 600$                        | $1.05 \times (1.8Sf + 0.01f + 0.2/Sf) + 4 \times 0.02Sf$  |
| NEXT (dB min.)              | $1 \leq f \leq 600$                        | $-20 \log(10^{-0.05(102.4-15\log(f))} + 2 \times 10^{-0.05(102.4-15\log(f))})$ , 65 dB max.   |
| PSNEXT (dB min.)            | $1 \leq f \leq 600$                        | $-20 \log(10^{-0.05(99.4-15\log(f))} + 2 \times 10^{-0.05(99.4-15\log(f))})$ , 62 dB max.   |
| ACR<br>(dB min.)            | $1 \leq f \leq 600$                        | $-20 \log(10^{-0.05(102.4-15\log(f))} + 2 \times 10^{-0.05(102.4-15\log(f))}) - (1.05 \times (1.8Sf + 0.01f + 0.2/Sf) + 4 \times 0.02Sf)$ |
| PSACR<br>(dB min.)          | $1 \leq f \leq 600$                        | $-20 \log((10^{-0.05(99.4-15\log(f))} + 2 \times 10^{-0.05(99.4-15\log(f))}) - (1.05 \times (1.8Sf + 0.01f + 0.2/Sf) + 4 \times 0.02Sf))$ |
| ELFEXT (dB min.)            | $1 \leq f \leq 600$                        | $-20 \log(10^{-0.05(94-20\log(f))} + 4 \times 10^{-0.05(90-15\log(f))})$ , 65 dB max.   |
| PSELFEXT (dB min.)          | $1 \leq f \leq 600$                        | $-20 \log(10^{-0.05(91-20\log(f))} + 4 \times 10^{-0.05(87-15\log(f))})$ , 62 dB max.   |
| Return loss (dB min.)       | $1 \leq f \leq 40$<br>$40 \leq f \leq 600$ | 24-5log(f), 19.0 dB max.<br>32-10log(f), 8.0db min.   |
| Prop. Delay ( $\mu$ s max.) | $1 \leq f \leq 600$                        | $0.534 + 0.036Sf + 4 \times 0.0025$   |
| Skew ( $\mu$ s max.)        | $1 \leq f \leq 600$                        | $0.015 + 4 \times 0.0025 = 0.025$   |

# Class F Channel

Presentations 2000

## Class F Channel

- performance upgrade over Class D (2002)
  - 3.2dB@100MHz Attenuation (~13%)
  - 32.8dB NEXT, PSNEXT
  - 27dB ELFEXT, PSELFEXT
  - ~2dB return loss
  - 20ns delay skew (RGB?)
- performance upgrade over Class E
  - 0.9dB@100MHz Attenuation (~4%)
  - 23dB NEXT, 22.8dB PSNEXT
  - 21dB ELFEXT, PSELFEXT
  - 20ns delay skew (RGB?)
- PSACR = 0dB at 501MHz

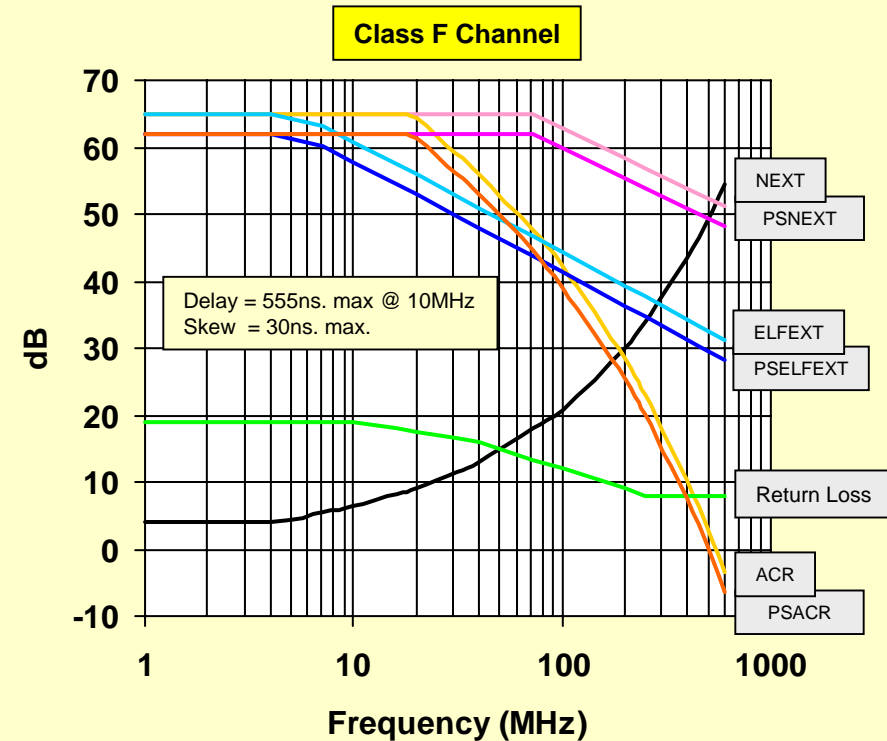
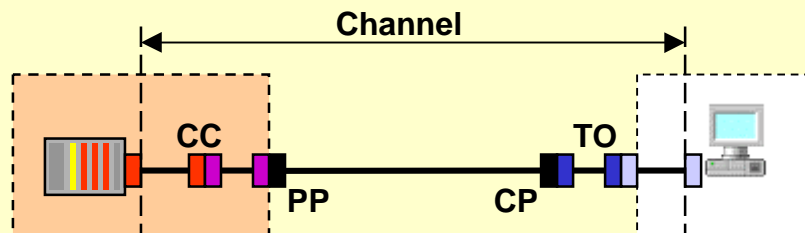

# Application of Channel Limits

## CHANNEL UNDER TEST

- attenuation values below 4dB
  - information only
- return loss values where attenuation < 3dB
  - information only
- NEXT values where attenuation < 4dB
  - conform to ACR requirements
- PSNEXT values where attenuation < 4dB
  - conform to PSACR requirements

# 4dB Exclusion

Presentations 2000

Attenuation < 4dB

**Approximate conditions**

- lengths below 15m @ 100MHz
- lengths below 30m @ 31.25MHz
- lengths below 40m @ 20MHz
- lengths below 55m @ 10MHz

**Rule**

- NEXT/PSNEXT reverts to ACR/PSACR

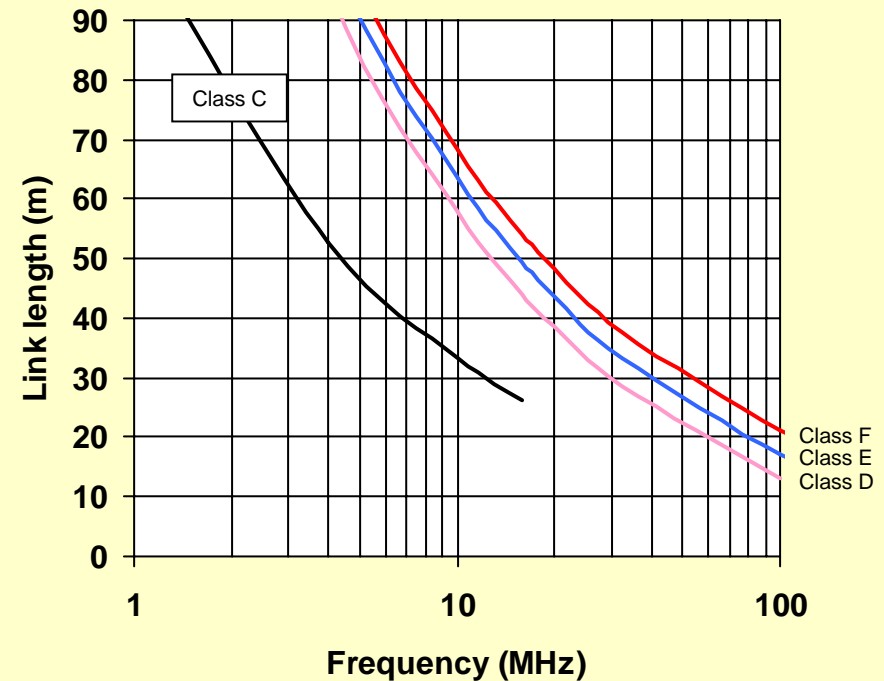

# 3dB Exclusion

Presentations 2000

Attenuation < 3dB

**Approximate conditions**

- lengths below 10m @ 100MHz
- lengths below 20m @ 31.25MHz
- lengths below 30m @ 20MHz
- lengths below 40m @ 10MHz

**Rule**

- Return loss is for information only
- NOT normative

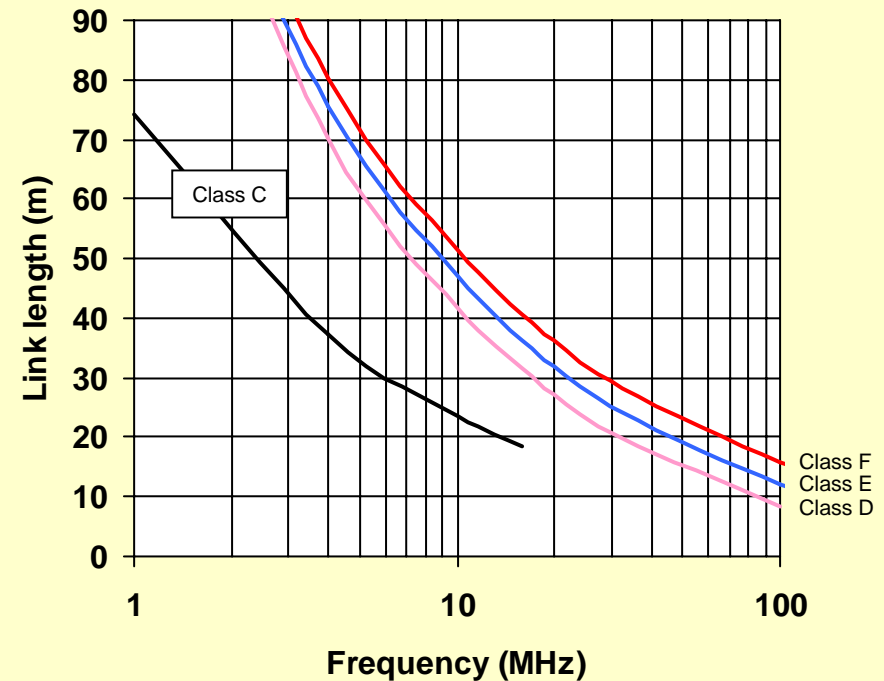

# Power over Pairs

| Class | Frequency | Maximum channel loop resistance (ohm) |
|-------|-----------|---------------------------------------|
| A     | d.c.      | 560                                   |
| B     | d.c.      | 170                                   |
| C     | d.c.      | 40                                    |
| D     | d.c.      | 25                                    |
| E     | d.c.      | 25                                    |
| F     | d.c.      | 25                                    |

| Class | Frequency | Max. channel resistance unbalance (ohm) |
|-------|-----------|---|
| D     | d.c.      | 1                                       |
| E     | d.c.      | 1                                       |
| F     | d.c.      | 1                                       |

| Class | Frequency | Min. channel current carrying capacity (A) |
|-------|-----------|--|
| D     | d.c.      | 0.175                                      |
| E     | d.c.      | 0.175                                      |
| F     | d.c.      | 0.175                                      |

# “Permanent Links” and “CP Links”

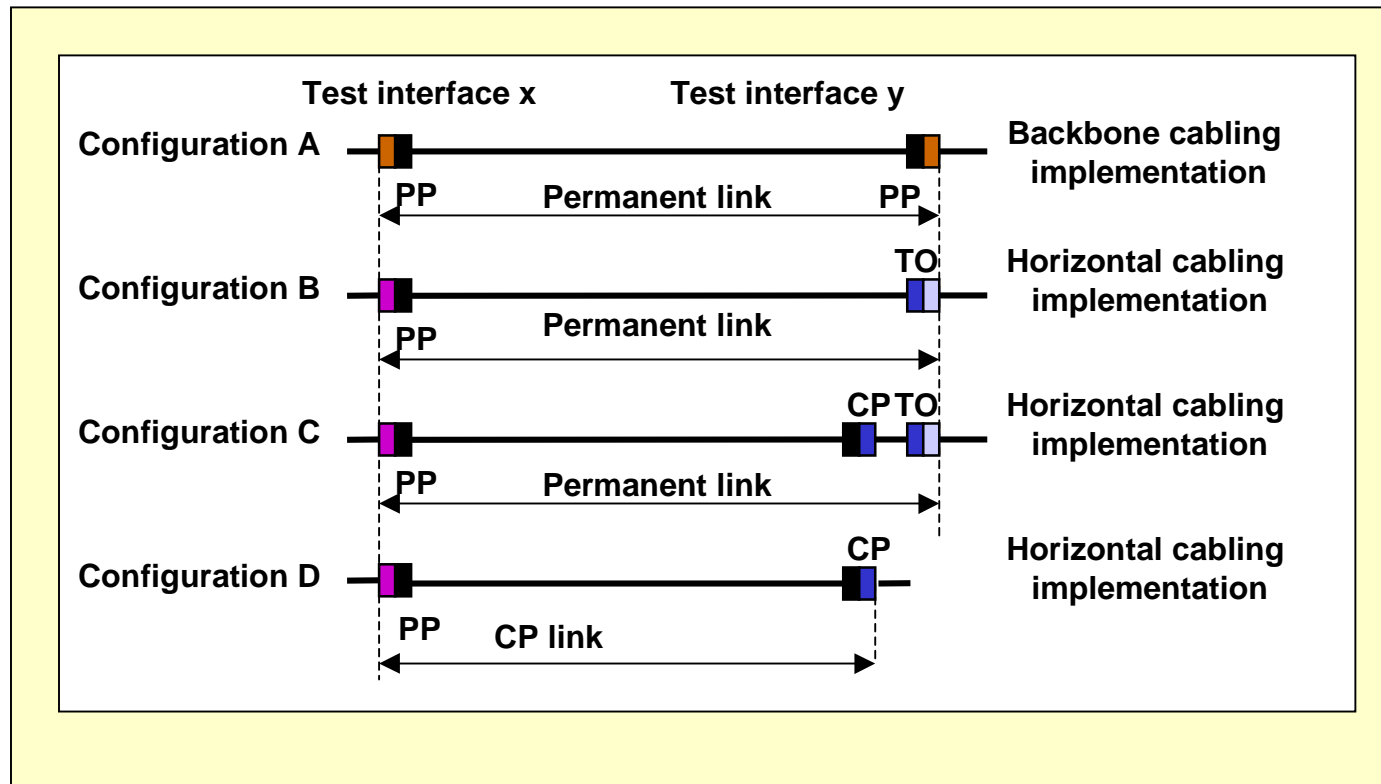

# Permanent Link Limits

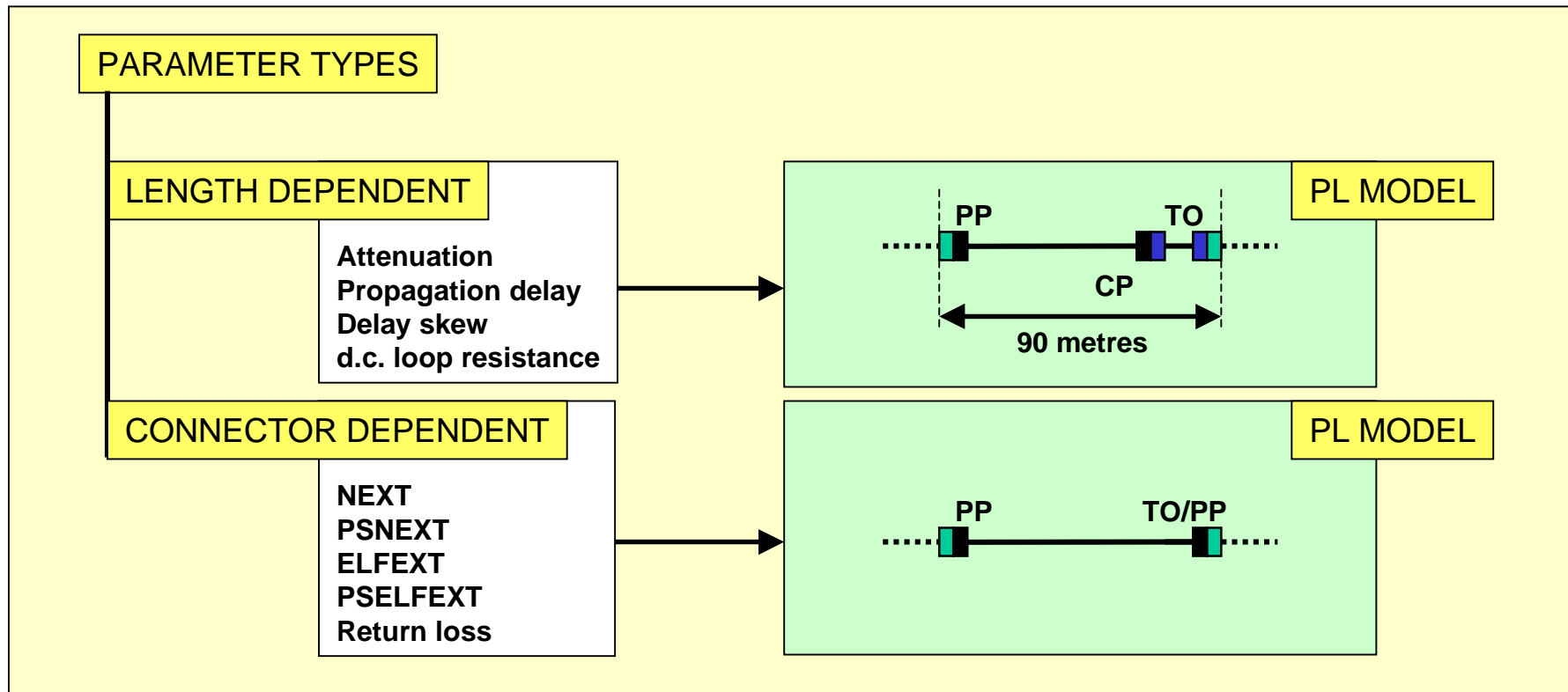



# Application of Permanent Link Limits

Presentations 2000

## LINK UNDER TEST

- attenuation values below 4dB
  - information only
- return loss values where attenuation < 3dB
  - information only
- NEXT values where attenuation < 4dB
  - conform to ACR requirements
- PSNEXT values where attenuation < 4dB
  - conform to PSACR requirements

## RULES

- Length dependent parameters
  - all configurations must meet PL limits
  - Configurations A, B and C must be design consistent
  - Configuration D must also meet CP Link rules
- Connector dependent parameters
  - all configurations must meet PL limits except
    - for low attenuation links
      - return loss, NEXT and PSNEXT
    - for Configuration C at TO
      - return loss, NEXT and PSNEXT

# CP Link Limits

Presentations 2000

| Parameter                   | Class | Frequency           | Channel formulae   |
|-----------------------------|-------|---------------------|--|
| Attenuation (dB max.)       | D     | $1 \leq f \leq 100$ | $L/100 \times (1.9108Sf+0.0222f+0.2/Sf) + 2 \times 0.02Sf$ |
|                             | E     | $1 \leq f \leq 250$ | $L/100 \times (1.82Sf+0.0169+0.25/Sf) + 2 \times 0.02Sf$   |
|                             | F     | $1 \leq f \leq 600$ | $L/100 \times (1.8Sf+0.01f+0.2/Sf) + 2 \times 0.02Sf$      |
| Prop. Delay ( $\mu$ s max.) | D     | $1 \leq f \leq 100$ | $L/100 \times (0.534 + 0.036Sf) + 2 \times 0.0025$         |
|                             | E     | $1 \leq f \leq 250$ |  |
|                             | F     | $1 \leq f \leq 600$ |  |
| Skew ( $\mu$ s max.)        | D     | $1 \leq f \leq 100$ | $L/100 \times (0.045) + 2 \times 0.0025$                   |
|                             | E     | $1 \leq f \leq 250$ |  |
|                             | F     | $1 \leq f \leq 600$ | $L/100 \times (0.010) + 2 \times 0.0025$                   |

# Configuration C Exclusion

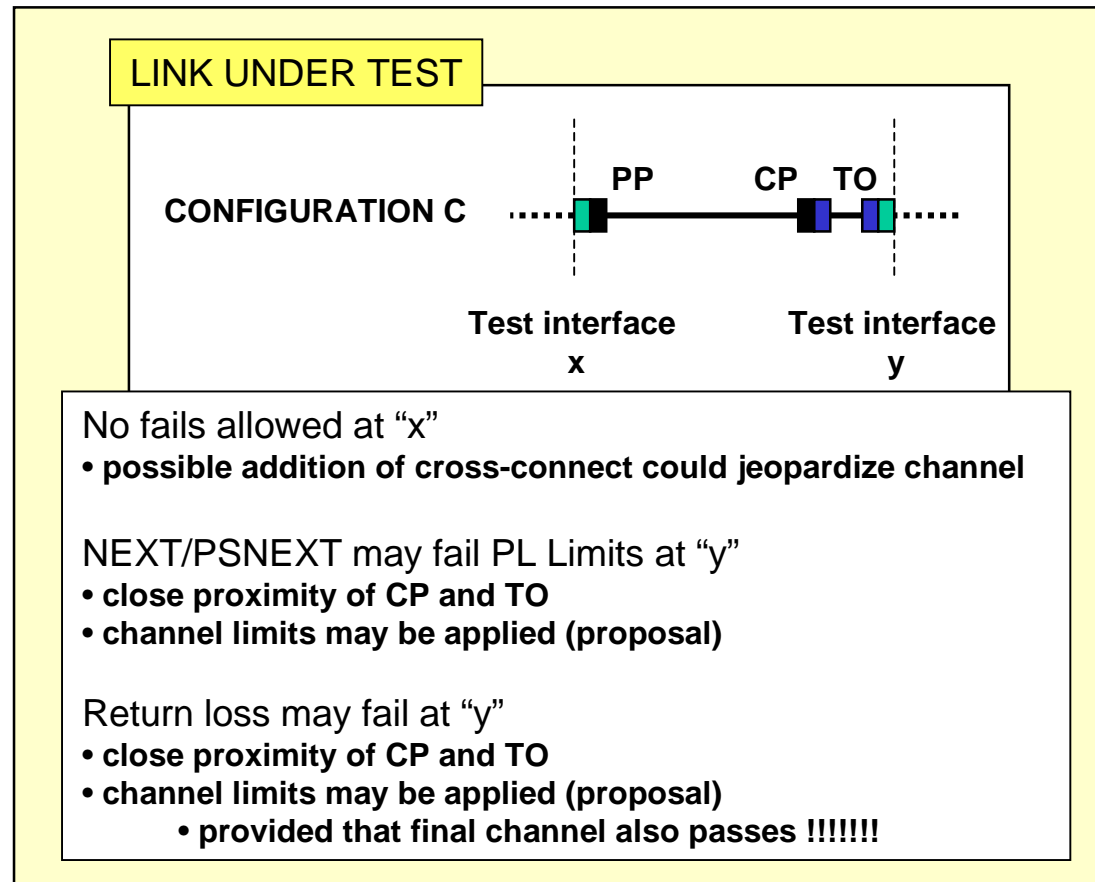

# Horizontal Implementation Rules

100 metres max.

FD CC PP CP TO WA

H, 15 metres min.

90 metres max.

$F_1$   $F_2$  C

$F = F_1 + F_2$

X = cord attenuation premium  
Y = CP cable attenuation premium (if any)

| No. of connections  | Class D/Category 5               | Class E/Category 6              | Class F/Category 7   |
|---|----------------------------------|---------------------------------|--|
| 2   | $H = (109 - FX) / T$             | $H = (107 - 3^1 - FX) / T$      | $H = (107 - 2^1 - FX) / T$   |
| 3 w/o. CP   | $H = (107 - FX) / T$             | $H = (106 - 3^1 - FX) / T$      | $H = (106 - 3^1 - FX) / T$   |
| 3 inc. CP   | $H = (107 - FX - CY) / T$        | $H = (106 - 3^1 - FX - CY) / T$ | $H = (106 - 3^1 - FX - CY) / T$  |
| 4   | $H = (105 - FX - CY) / T$        | $H = (105 - 3^1 - FX - CY) / T$ | $H = (105 - 4^1 - FX - CY) / T$  |
| $T = 1 + (t - 20) \times \alpha$ where t = maximum design temperature within link |                                  |                                 |  |
|   | for screened cables              |                                 | for unscreened cables  |
| X and Y   | 1.5 typically                    |                                 | 1.2 typically  |
| $\alpha$  | = 0.2 for $t > 20^\circ\text{C}$ |                                 | = 0.4 for $20^\circ\text{C} < t < 40^\circ\text{C}$<br>= 0.6 for $40^\circ\text{C} < t < 60^\circ\text{C}$ |
| Note 1: this length reduction is provides margin for insertion loss deviation.    |                                  |                                 |  |

# Worst Case Modelling

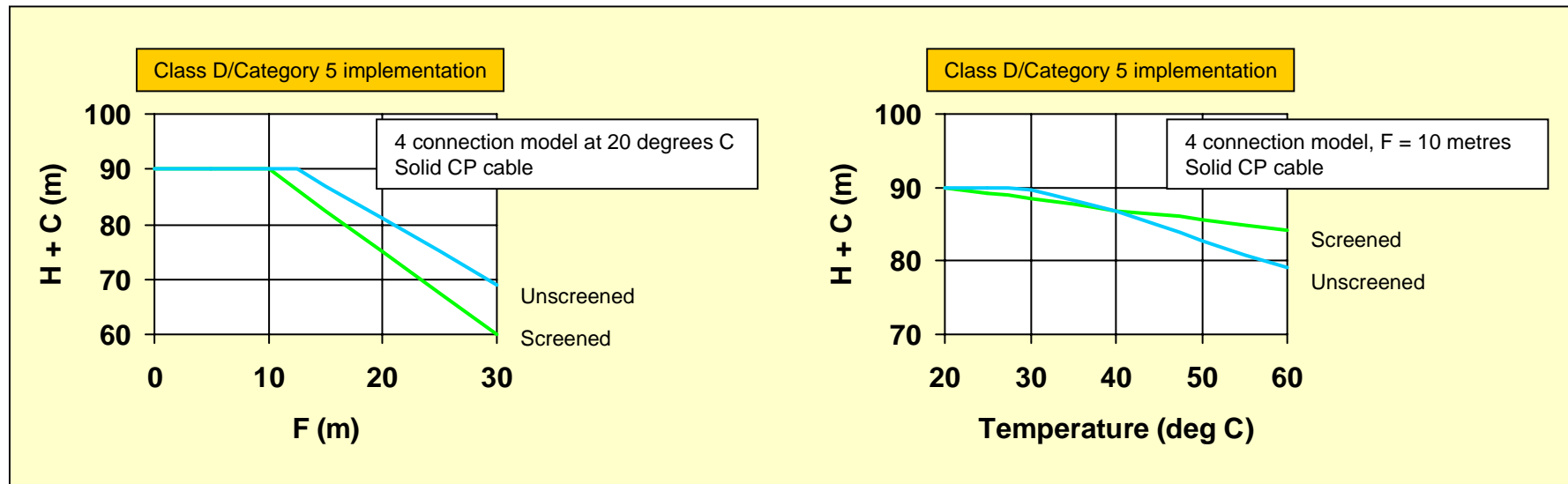

# Backbone Channel Design

Presentations 2000

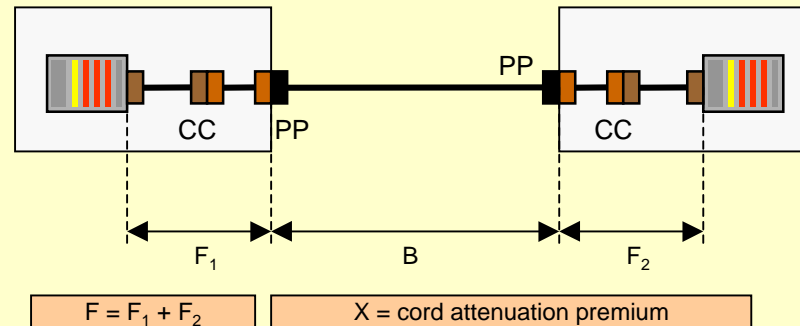

| Category   | Class A             | Class B        | Class C        | Class D                                      | Class E                        | Class F                        |
|--|---------------------|----------------|----------------|--|--------------------------------|--------------------------------|
| 5 <sup>1</sup>   | B = 2000            | B = (250-FX)/T | B = (170-FX)/T | B = (105-FX)/T                               |                                |                                |
| 6 <sup>2</sup>   | B = 2000            | B = (260-FX)/T | B = (185-FX)/T | B = (111-FX)/T                               | B = (106-3 <sup>3</sup> -FX)/T |                                |
| 7 <sup>2</sup>   | B = 2000            | B = (260-FX)/T | B = (190-FX)/T | B = (115-FX)/T                               | B = (107-3 <sup>3</sup> -FX)/T | B = (105-4 <sup>3</sup> -FX)/T |
| T = 1 + (t-20) x α where t = maximum design temperature within link            |                     |                |                |  |                                |                                |
|  | for screened cables |                |                | for unscreened cables                        |                                |                                |
| X  | 1.5 typically       |                |                | 1.2 typically                                |                                |                                |
| α  | = 0.2 for t>20°C    |                |                | = 0.4 for 20°C<t<40°C, = 0.6 for 40°C<t<60°C |                                |                                |
| Note 1: B can be increased by 2 metres for each connection removed             |                     |                |                |  |                                |                                |
| Note 2: B can be increased by 1 metre for each connection removed              |                     |                |                |  |                                |                                |
| Note 3: this length reduction is provides margin for insertion loss deviation. |                     |                |                |  |                                |                                |

# EN 50174 Standards

Presentations 2000

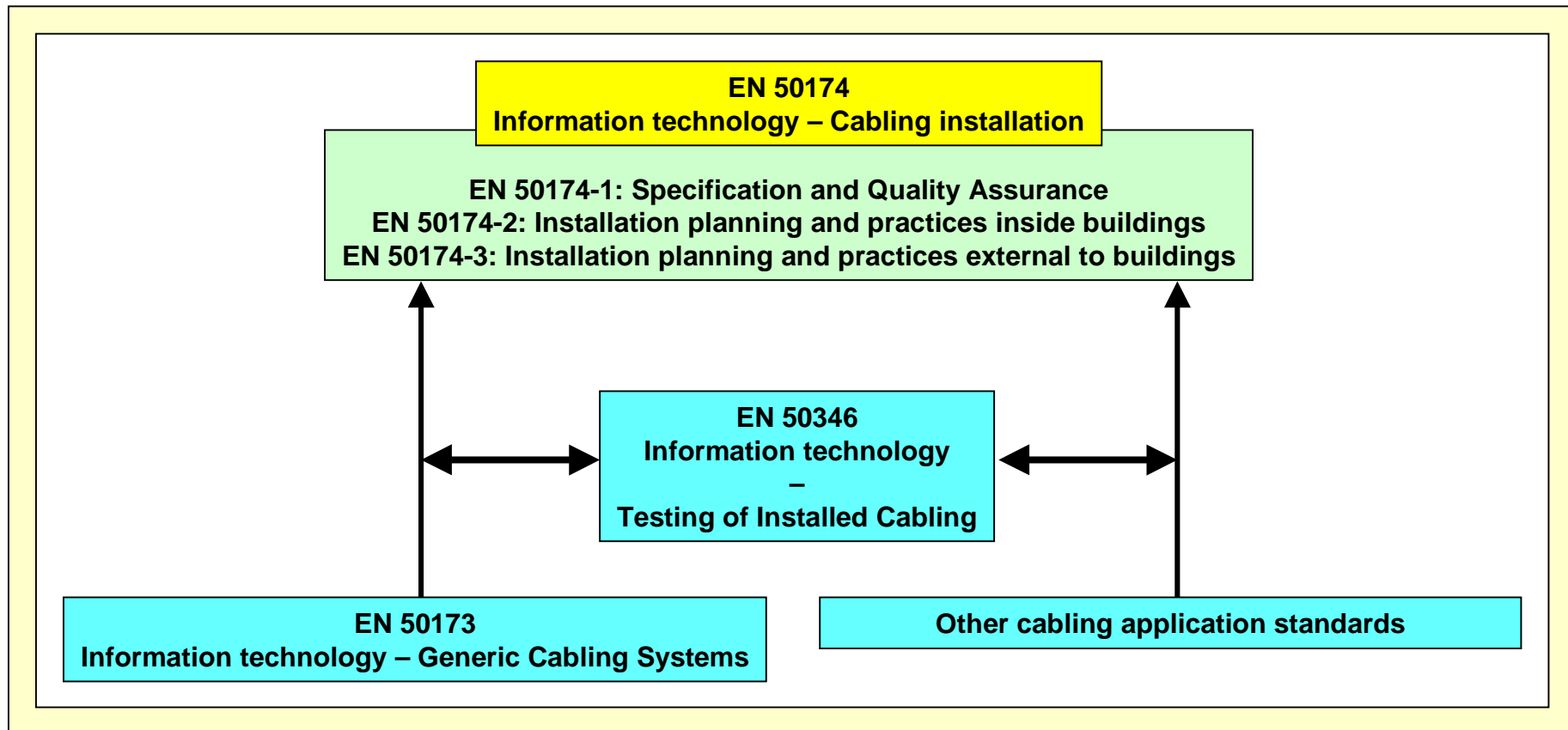

# EN 50174 Status

Presentations 2000

## EN 50174

### Information technology – Cabling installation

**EN 50174-1: Specification and Quality Assurance  
APPROVED FOR PUBLICATION**

**EN 50174-2: Installation planning and practices inside buildings  
APPROVED FOR PUBLICATION**

**EN 50174-3: Installation planning and practices external to buildings  
TECHNICAL COMMITTEE ENQUIRY Q3, 2000  
PUBLICATION IN 2001**

# The Impact of EN 50174

**BS EN 50174-1: Information technology – Cabling installation - Specification and Quality Assurance**

**BS EN 50174-2: Information technology – Cabling installation - Installation planning and practices inside buildings**

**Published 01/01**

**“In force” 08/01**

**BS 6701 - A Code of Practice for  
“Installation of Apparatus intended for  
connection to certain Telecommunications  
Systems”**

- applies to cabling connected to a PABX

**to be reviewed and possibly revised**

**BS 7671**

- The Wiring Regulations (IEE)

**untouched**

# Application Support

Presentations 2000

|         | APPLICATION           | SPECIFICATION REFERENCE             | DATE    | ADDITIONAL NAME                        |
|---------|-----------------------|-------------------------------------|---------|--|
| Class A | PBX                   | National Requirements               |         |  |
|         | X.21                  | ITU-T Rec. X.21                     | 1994    |  |
|         | V.11                  | ITU-T Rec. X.21                     | 1994    |  |
| Class B | S0 Bus (extended)     | ITU-T Rec. I.430                    | 1993    | ISDN Basic Access (Physical Layer)     |
|         | S0 Point-to-point     | ITU-T Rec. I.430                    | 1993    | ISDN Basic Access (Physical Layer)     |
|         | S1/S2                 | ITU-T Rec. I.431                    | 1993    | ISDN Primary Access (Physical Layer)   |
|         | CSMA/CD 1BASE5        | ISO/IEC 8802-3                      | 1996    | Starlan                                |
| Class C | CSMA/CD 10Base-T      | ISO/IEC 8802-3                      | 1996    |  |
|         | Token Ring 4 Mbit/s   | ISO/IEC 8802-5                      | 1995    |  |
|         | ISLAN                 | ISO/IEC 8802-9                      | 1996    | Integrated Services LAN                |
|         | Demand priority       | ISO/IEC DIS 8802-12                 | 1997    | VGAnyLAN                               |
|         | ATM LAN 25.60 Mbit/s  | ATM Forum af-phy-0040.000           | 1995    | ATM-25/Category 3                      |
|         | ATM LAN 51.84 Mbit/s  | ATM Forum af-phy-0018.000           | 1994    | ATM-52/Category 3                      |
|         | ATM LAN 155.52 Mbit/s | ATM Forum af-phy-0047.000           | 1995    | ATM-155/Category 3                     |
|         | CSMA/CD 100Base-T4    | ISO/IEC 8802-3 DAM21 (IEEE 802.3u)  | 1997(5) | Fast Ethernet                          |
|         | CSMA/CD 100Base-T2    | ISO/IEC 8802-3 PDAM25 (IEEE 802.3y) | 1997(7) | Fast Ethernet                          |
|         | ISLAN16-T             | ISO/IEC 8802-9 DAM1 (IEEE 802.9a)   | 1997(5) | Integrated Services LAN                |
| Class D | Token Ring 16 Mbit/s  | ISO/IEC 8802-5                      | 1995    |  |
|         | TP-PMD                | ISO/IEC DIS 9314-10                 | 1997    | Twisted-Pair Physical Medium Dependent |
|         | ATM LAN 155.52 Mbit/s | ISO/IEC 8802-5                      | 1994    | ATM-155/Category 5                     |
|         | CSMA/CD 100Base-TX    | ISO/IEC 8802-3 DAM21 (IEEE 802.3u)  | 1997(5) | Fast Ethernet                          |
|         | Token Ring 100 Mbit/s | IEEE 802.5t                         | 1999    | High speed Token Ring                  |
|         | CSMA/CD 1000Base-T    | IEEE 802.3ab                        | 1999    | Gigabit Ethernet                       |

# Pin-Pair Mapping

Presentations 2000

|         | APPLICATION           | No. of pairs | 1 and 2 | 3 and 6  | 4 and 5 | 7 and 8 |
|---------|-----------------------|--------------|---------|----------|---------|---------|
| Class A | PBX                   | 1-4          |         |          |         |         |
|         | X.21                  | 2            |         | Class A  | Class A |         |
|         | V.11                  | 2            |         | Class A  | Class A |         |
| Class B | S0 Bus (extended)     | 2 (4)        | (power) | Class B  | Class B | (power) |
|         | S0 Point-to-point     | 2 (4)        | (power) | Class B  | Class B | (power) |
|         | S1/S2                 | 2 (4)        | Class B | (screen) | Class B | (power) |
|         | CSMA/CD 1BASE5        | 2            | Class B | Class B  |         |         |
| Class C | CSMA/CD 10Base-T      | 2            | Class C | Class C  |         |         |
|         | Token Ring 4 Mbit/s   | 2            |         | Class C  | Class C |         |
|         | ISLAN                 | 2            | Class C | Class C  |         |         |
|         | Demand priority       | 4            | Class C | Class C  | Class C | Class C |
|         | ATM LAN 25.60 Mbit/s  | 2            | Class C |          |         | Class C |
|         | ATM LAN 51.84 Mbit/s  | 2            | Class C |          |         | Class C |
|         | ATM LAN 155.52 Mbit/s | 2            | Class C |          |         | Class C |
|         | CSMA/CD 100Base-T4    | 4            | Class C | Class C  | Class C | Class C |
|         | CSMA/CD 100Base-T2    | 2            | Class C | Class C  |         |         |
|         | ISLAN16-T             | 2            | Class C | Class C  |         |         |
| Class D | Token Ring 16 Mbit/s  | 2            |         | Class D  | Class D |         |
|         | TP-PMD                | 2            | Class D |          |         | Class D |
|         | ATM LAN 155.52 Mbit/s | 2            | Class D |          |         | Class D |
|         | CSMA/CD 100Base-TX    | 2            | Class D | Class D  |         |         |
|         | Token Ring 100 Mbit/s | 2            |         | Class D  | Class D |         |
|         | CSMA/CD 1000Base-T    | 4            | Class D | Class D  | Class D | Class D |

# Class E and F Applications

## Cat 5e supports

- **1000BASE-T over 100m, 4 connectors**
  - margin on return loss
  - typical lengths provide adequate S/N
  - 2 or 3 connectors provide adequate S/N

## Cat 6 supports

- **1000BASE-T over 100m, 4 connectors**
  - significant margin on NEXT, ELFEXT over Cat. 5e

## Cat 6 applications

- **Low Cost 1000BASE-T over 100m, 4 connectors**
  - TIA activity PN 4657 (not supported by IEEE)
- **ATM 1.2Gb/s using 1000BASE-T technology**
  - in development by ATM Forum

Cat 7 will support all the above

## Cat 7 applications

- **1062Mb/s FiberChannel**
  - in development by ISO
- **various video services claim support**

# The Importance of Connectors

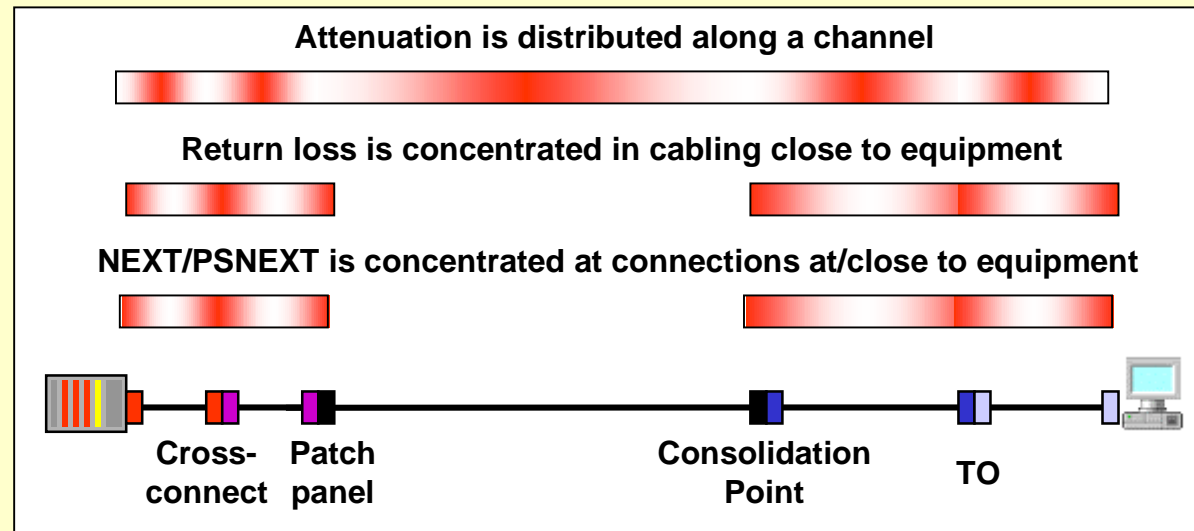

## Non-interoperability AND backwards incompatibility

- standards do not guarantee electrical (or even physical) performance of an open system joint  
“pending resolution of this guarantees shall be sought from manufacturers”

## Screen continuity/performance

- no agreed standard or specification for inter-component screen connection

# The Importance of Cords

Presentations 2000

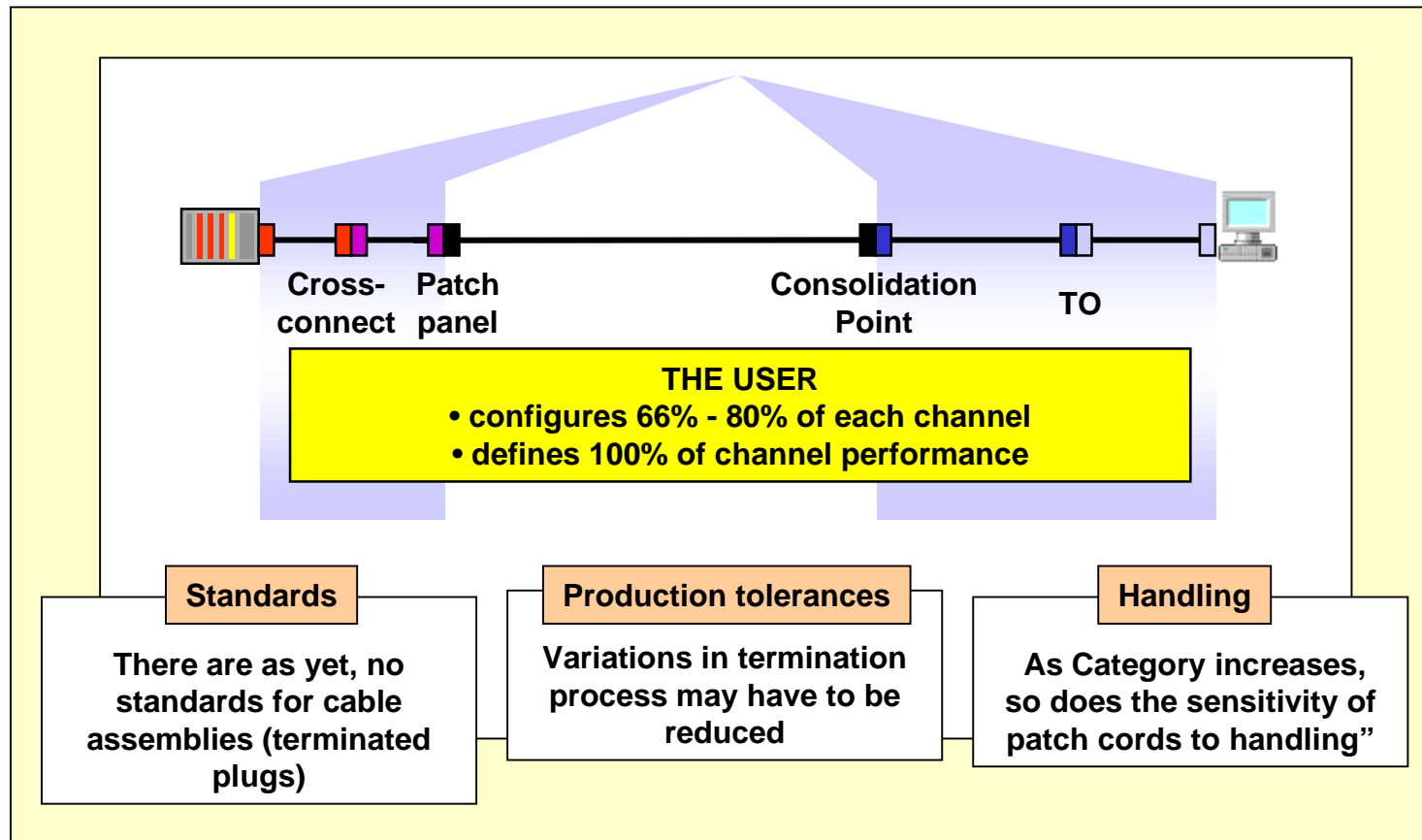

# The Impact of Higher Categories

Presentations 2000

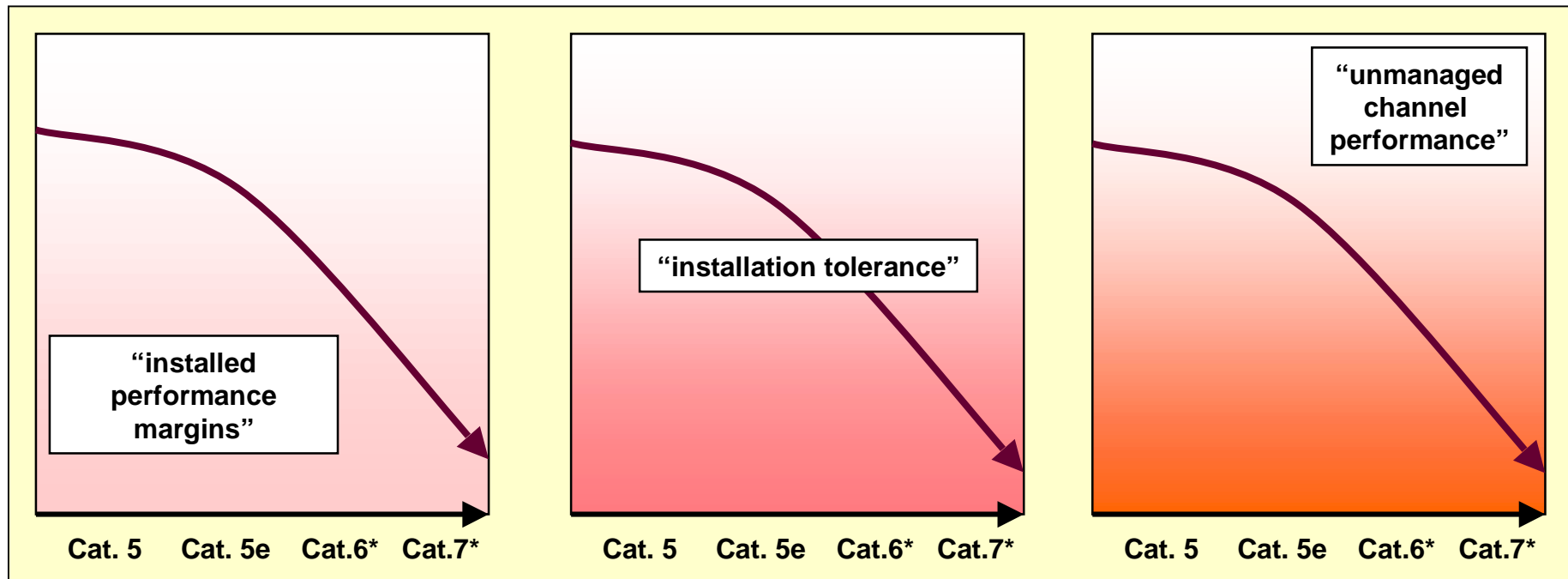

# Agenda

Presentations 2000

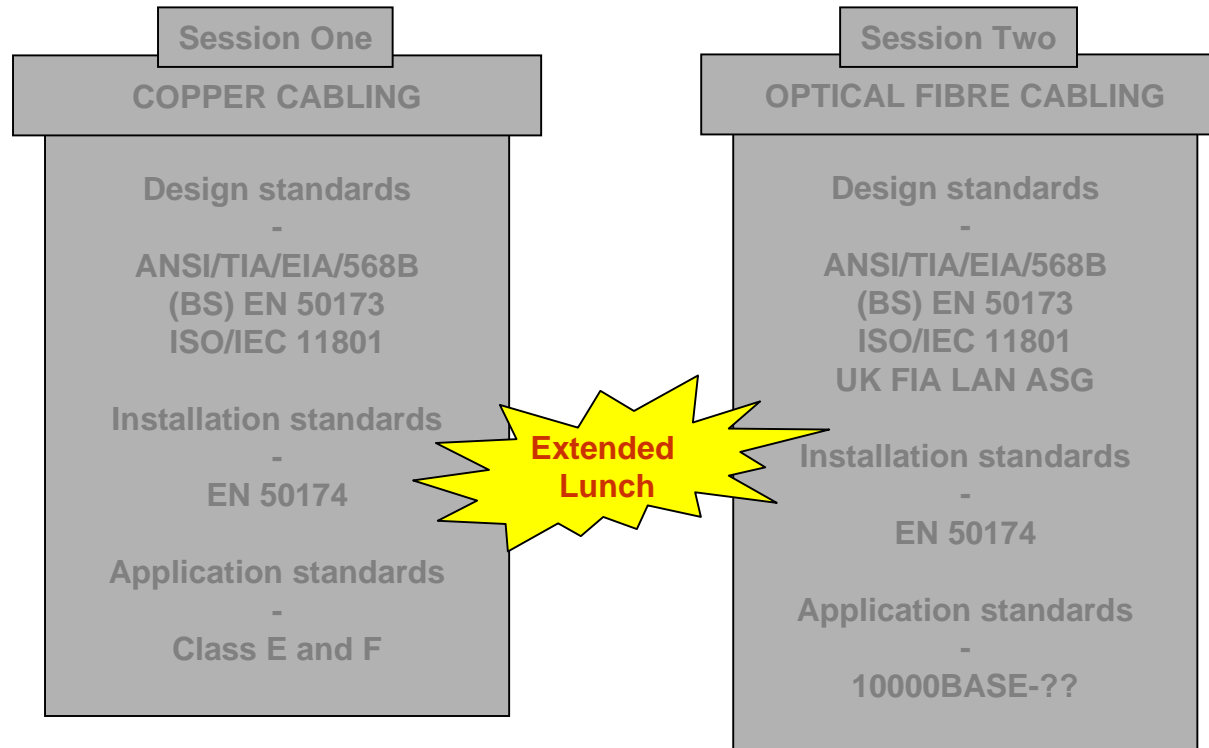

# Agenda

Presentations 2000

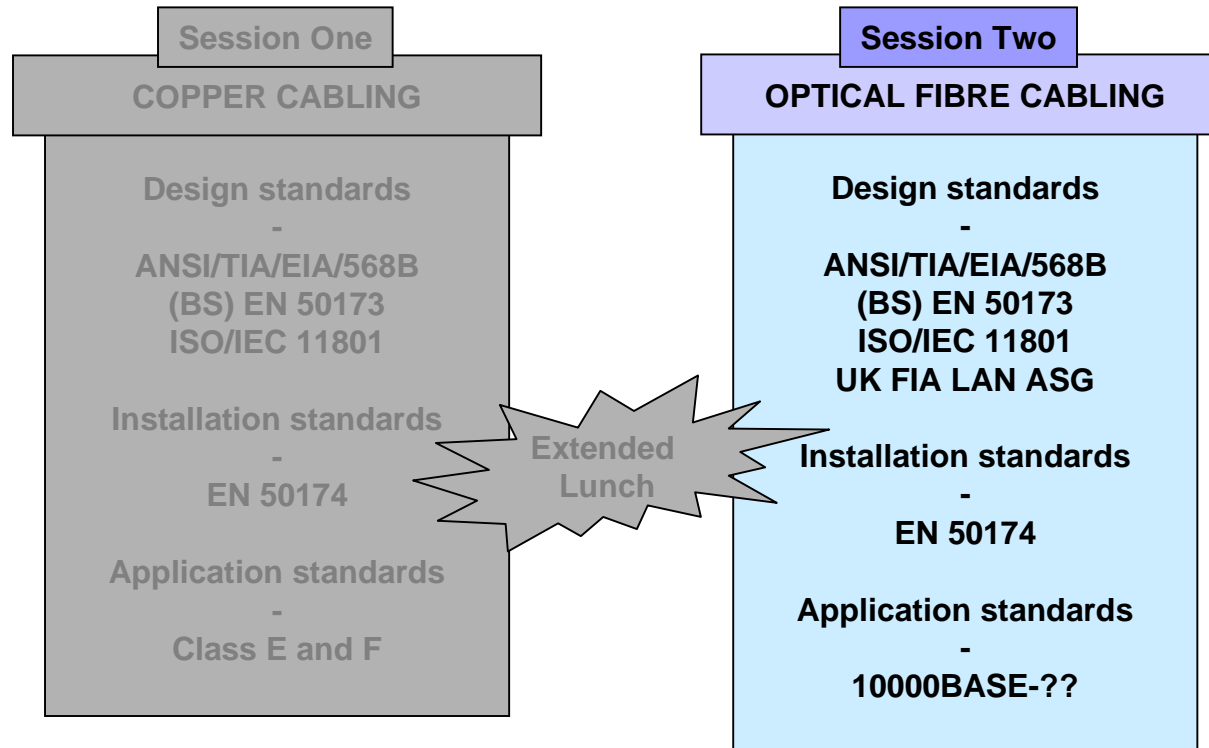



# Design Standards (1995 and 2000)

Presentations 2000

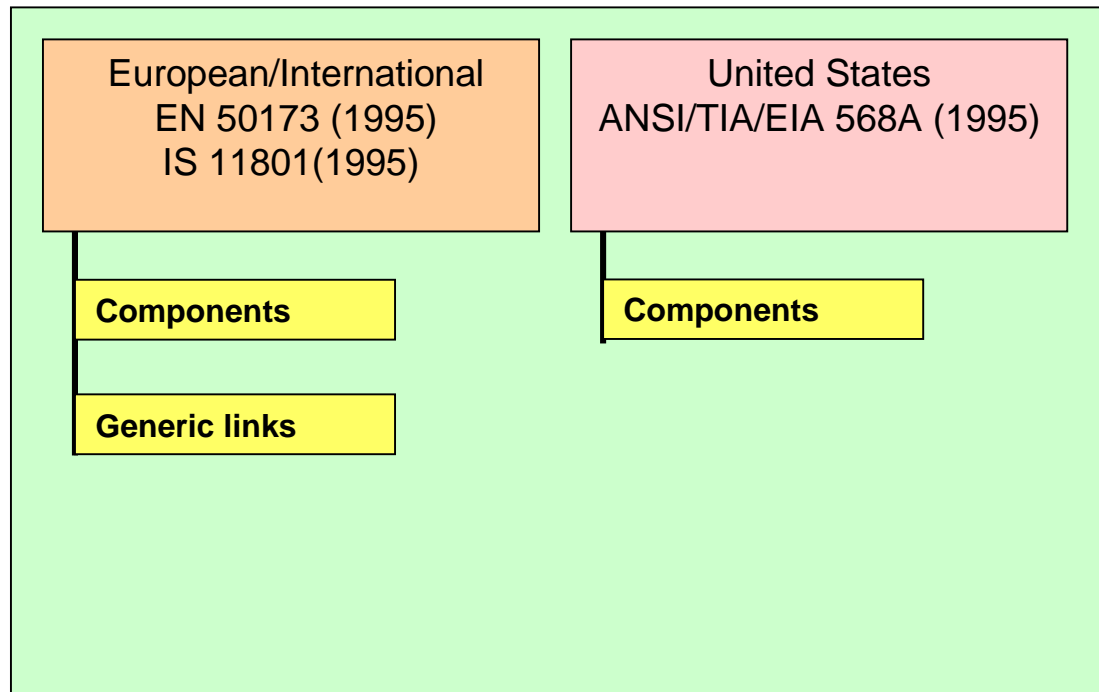

# Next Generation Standards

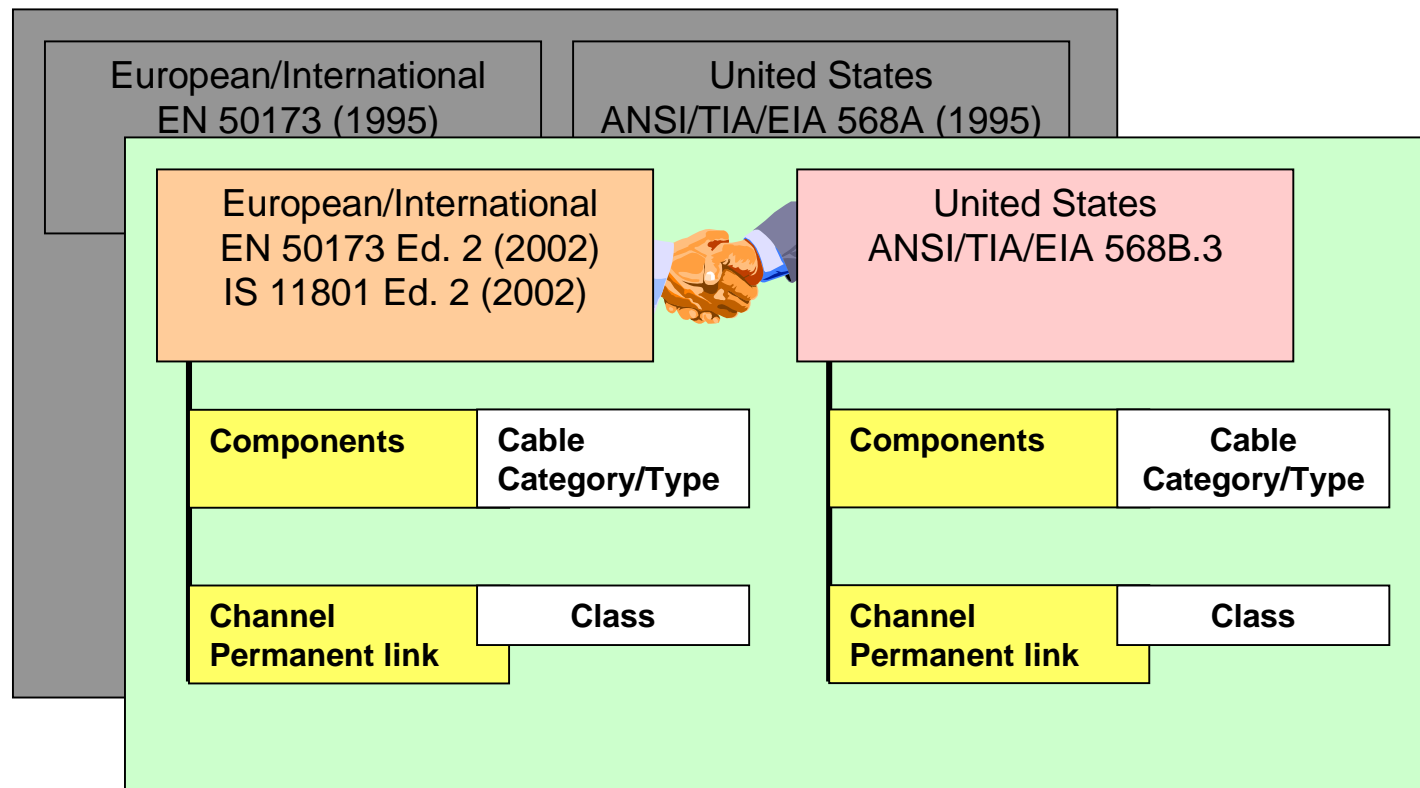

# Attenuation vs. Modal Bandwidth

Presentations 2000

Old applications have channel lengths defined by attenuation

New applications have channel lengths defined by modal bandwidth

- longer lengths cannot be guaranteed even if low attenuation channels are used

Modal bandwidths have rarely been specified by users/installers

Modal bandwidth difficult/impossible to measure on-site

- bandwidth-limited applications are installed with higher risk

**OPTICAL FIBRE SELECTION AND CONFIGURATION IMPACTED**

|                    | Attenuation coefficient<br>dBkm <sup>-1</sup> max. |        | Modal bandwidth<br>MHz.km min. |        |                                  |
|--------------------|--|--------|--------------------------------|--------|----------------------------------|
|                    | 850nm  | 1300nm | 850nm                          | 1300nm |                                  |
| 50/125 or 62.5/125 | 3.5  | 1.0    | 200                            | 500    | IS 11801 (1995), EN 50173 (1995) |
| 62.5/125           | 3.75   | 1.5    | 160                            | 500    | ANSI/TIA/EIA 568A (1995)         |
| 50 or 62.5/125     | 3.5  | 1.5    | 500                            | 500    | IS 11801 (2002), EN 50173 (2002) |
|                    | 3.5  | 1.5    | 200                            | 500    |                                  |
|                    | 3.5  | 1.5    | 2000                           | 500    |                                  |

# OF Cable Category/Type

Presentations 2000

| Generic OF specification: IEC 60793-2            |            |     |     |      |               |     |
|--|------------|-----|-----|------|---------------|-----|
| Test methods: IEC 60793-1                        |            |     |     |      |               |     |
| Mechanical requirements: IEC 60794-1 and -2      |            |     |     |      |               |     |
| 50/125 or 62.5/125                               |            |     |     |      |               |     |
| Multimode OF                                     |            |     |     |      | Singlemode OF |     |
|  | Wavelength | OM1 | OM2 | OM3  | Wavelength    | OS1 |
| Attenuation coefficient (dBkm <sup>-1</sup> max) | 850nm      | 3.5 |     |      | 1310nm        | 1.0 |
|  | 1300nm     | 1.5 |     |      | 1550nm        | 1.0 |
| Modal bandwidth OFL (MHz.km min)                 | 850nm      | 200 | 500 | 500  |               |     |
|  | 1300nm     | 500 | 500 | 500  |               |     |
| Modal bandwidth LL (MHz.km min)                  | 850nm      | ffs | ffs | 2000 |               |     |
|  | 1300nm     | ffs | ffs | ffs  |               |     |
| Propagation delay (ns.m <sup>-1</sup> max)       | 850nm      | 5   |     |      | 1310nm        | 5   |
|  | 1300nm     |     |     |      | 1550nm        |     |

# OF Connectors for IT Cabling

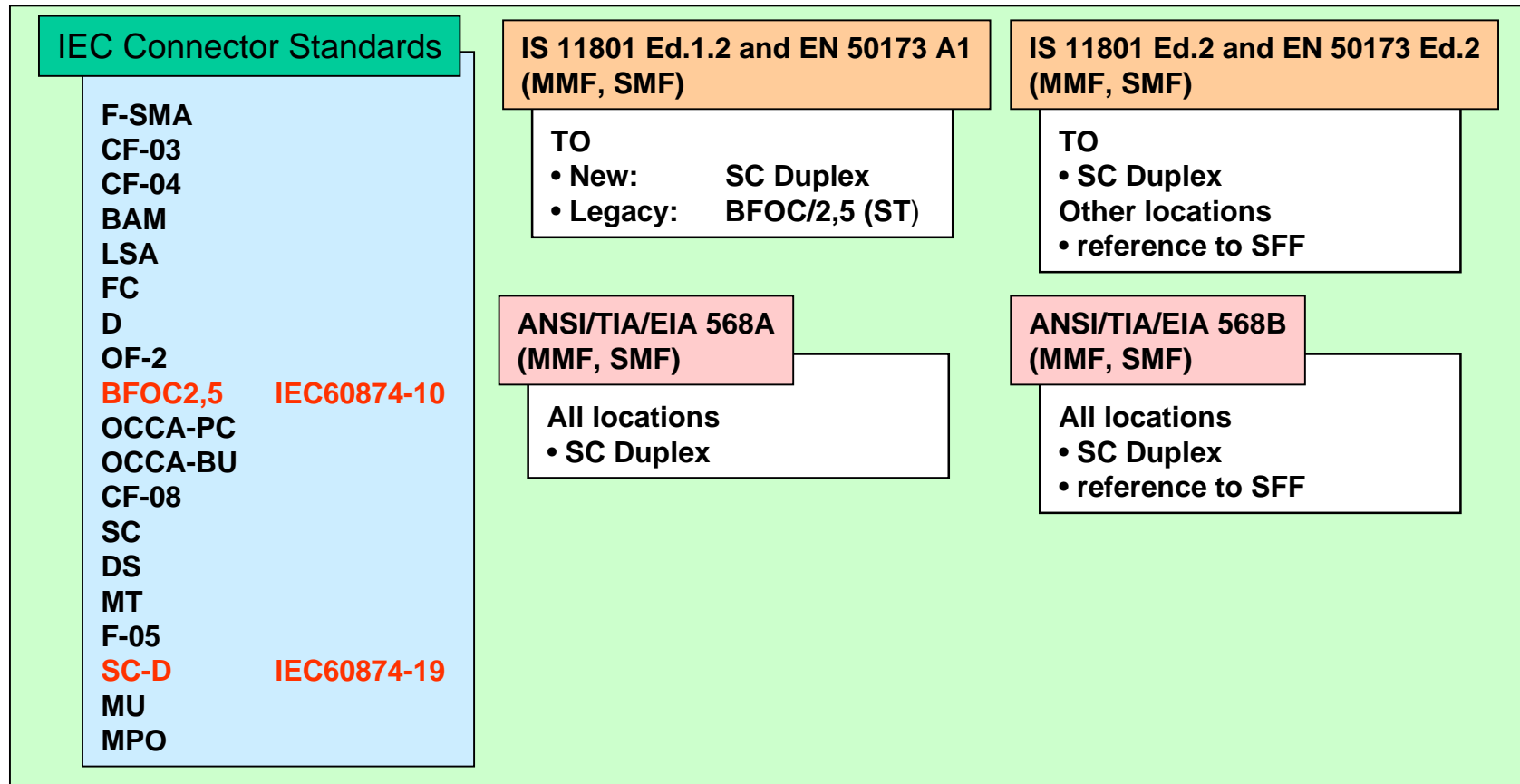

# SFF Optical Fibre Connectors

## SMALL FORM FACTOR

- duplex termination
- RJ45 face area

MT-RJ, SG (Volition), LC

- no interoperability standards

### Advantages

- small face area
  - benefits for equipment and patch panels
  - no benefit for TO
    - OF bend radius defines “backbox” dimensions
- duplex termination
  - benefits for equipment
- no benefit
  - video
  - bi-directional simplex applications

### The future within “standards”

- no clear advantage over existing solutions
  - performance
  - overall installation cost
- disadvantages
  - too many choices
  - no clear “winner”
- will SFF go away?
  - definitely NOT

# OF Connecting Hardware

| SPLICES                                | Insertion loss (max.) |  | Return loss |           |
|--|-----------------------|--|-------------|-----------|
|  | Singlemode/multimode  |  | Singlemode  | Multimode |
| ISO/IEC 11801 and EN 50173 (1995/2002) | 100% < 0.30 dB        |  | -           | -         |

## DEMOUNTABLE CONNECTING HARDWARE: INTEROPERABILITY STANDARDS

|   |                | Insertion loss (max.) |  | Return loss |           |
|---|----------------|-----------------------|--|-------------|-----------|
|   |                | Singlemode/multimode  |  | Singlemode  | Multimode |
| TO in ISO/IEC 11801 and EN 50173 (1995) |                | 100% < 0.75 dB        |  | 26dB        | 20dB      |
| ST (BFOC2,5): MMF                       | IEC 60874-10   |                       |  |             |           |
| SC-D (duplex ): MMF                     | IEC 60874-19-1 |                       |  |             |           |

|   |                |                              |  |      |      |
|---|----------------|------------------------------|--|------|------|
| TO in ISO/IEC 11801 and EN 50173 (2002) |                |                              |  |      |      |
| SC-D (duplex ): MMF                     | IEC 60874-19-1 | 95% < 0.5 dB, 100% < 0.75 dB |  | 35dB | 20dB |

## DEMOUNTABLE CONNECTING HARDWARE: ALTERNATIVE INTERFACE STANDARDS

| Interoperability not guaranteed by standards   |   |
|--|---|
| F-SMA, CF-03, CF-04, BAM, LSA, FC, D, OF-2, OCCA-PC, OCCA-BU, CF-08, SC, DS, F-05, MU, MPO | SFF types in preparation:<br>LC, SG (Volition), MT-RJ |

# OF Channel Classes

Presentations 2000

|       |         | Maximum attenuation (dB) |        |            |        |
|-------|---------|--------------------------|--------|------------|--------|
|       |         | Multimode                |        | Singlemode |        |
|       |         | 850nm                    | 1300nm | 1310nm     | 1550nm |
| Class | OF-300  | 2.55                     | 1.95   | 1.80       | 1.80   |
|       | OF-500  | 3.25                     | 2.25   | 2.00       | 2.00   |
|       | OF-2000 | 8.50                     | 4.50   | 3.50       | 3.50   |

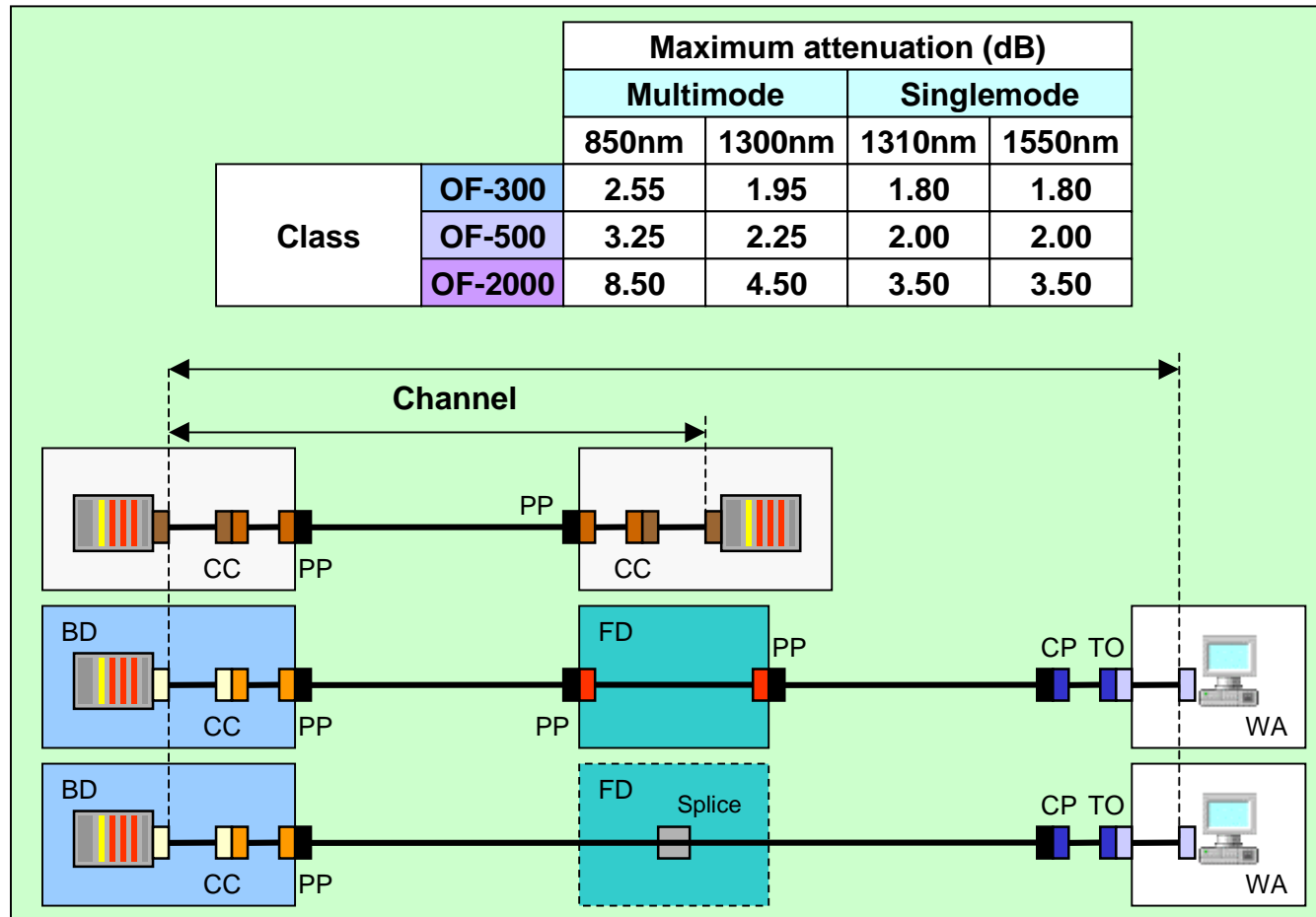

# OF Channel Implementations

Presentations 2000

|           |               | L = channel length (m) |                   |                            |                             |
|-----------|---------------|------------------------|-------------------|----------------------------|-----------------------------|
|           |               | Cable Category         | Class             | $\lambda = 850 \text{ nm}$ | $\lambda = 1300 \text{ nm}$ |
| Multimode | OM1, OM2, OM3 | OF-300                 | L = 735-145x-90y  | L = 1300-330x-200y         | 300                         |
|           |               | OF-500                 | L = 935-145x-90y  | L = 1500-330x-200y         | 500                         |
|           |               | OF-2000                | L = 2435-145x-90y | L = 2435-330x-200y         | 2000                        |

|            |     | L = channel length (m) |                    |                             |                             |
|------------|-----|------------------------|--------------------|-----------------------------|-----------------------------|
|            |     | Cable Category         | Class              | $\lambda = 1310 \text{ nm}$ | $\lambda = 1550 \text{ nm}$ |
| Singlemode | OS1 | OF-300                 | L = 1800-500x-300y | L = 1800-500x-300y          | 300                         |
|            |     | OF-500                 | L = 2000-500x-300y | L = 2000-500x-300y          | 500                         |
|            |     | OF-2000                | L = 3500-500x-300y | L = 3500-500x-300y          | 2000                        |

Where:  
x = no. of mated connections in the channel  
y = no. of splices in the channel

0.5dB = 145m of 3.5dBkm<sup>-1</sup> cable  
0.3dB = 90m of 3.5dBkm<sup>-1</sup> cable

0.5dB = 330m of 1.5dBkm<sup>-1</sup> cable  
0.3dB = 200m of 1.5dBkm<sup>-1</sup> cable

0.5dB = 500m of 1.0dBkm<sup>-1</sup> cable  
0.3dB = 300m of 1.0dBkm<sup>-1</sup> cable

# OF-300 Channel Implementations

Presentations 2000

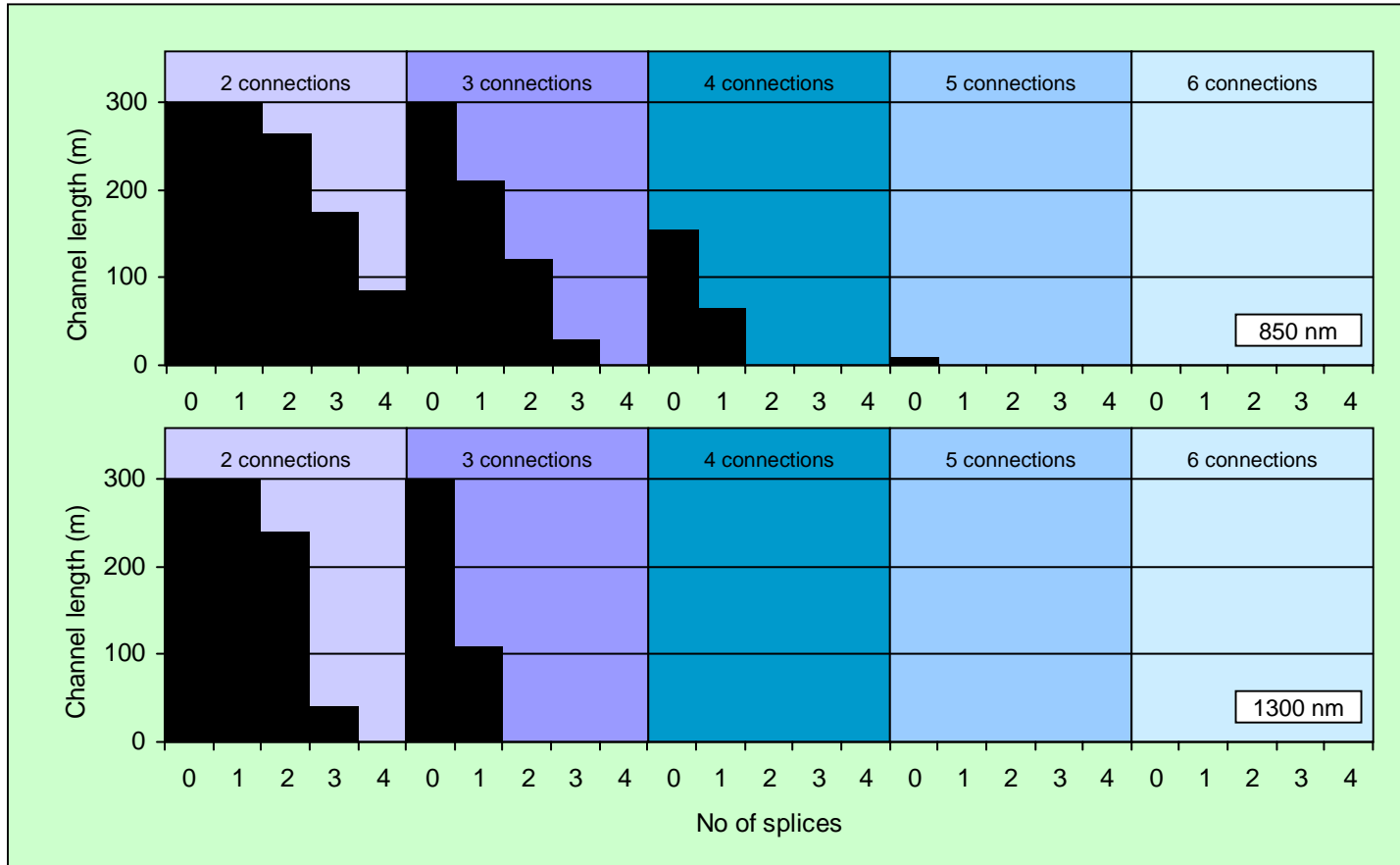

# Application Mapping

Presentations 2000

| APPLICATION                    | Optical power budget (dB) |            |        | Optical channel class using |         |         |         |         |         |         |
|--------------------------------|---------------------------|------------|--------|-----------------------------|---------|---------|---------|---------|---------|---------|
|                                | MMF                       |            | SMF    | OF OM1                      |         | OF OM2  |         | OF OM3  |         | OF OS1  |
|                                | 850nm                     | 1300nm     | 1310nm | 850nm                       | 1300nm  | 850nm   | 1300nm  | 850nm   | 1300nm  | 1310nm  |
| ISO/IEC 8802-3: FOIRL          | 9.0 (3.3)                 |            |        | OF-2000                     |         | OF-2000 |         | OF-2000 |         |         |
| ISO/IEC 8802-3: 10BASE-FL/FB   | 12.5 (6.8)                |            |        | OF-2000                     |         | OF-2000 |         | OF-2000 |         |         |
| ISO/IEC 8802-5: TR 4/16 Mbit/s | 13.0 (8.0)                |            |        | OF-2000                     |         | OF-2000 |         | OF-2000 |         |         |
| IEEE 802-12: Demand priority   | 7.5 (2.8)                 |            |        | OF-500                      |         | OF-500  |         | OF-500  |         |         |
| ATM-52                         |                           | 10.0 (5.3) | 10.0   |                             | OF-2000 |         | OF-2000 |         | OF-2000 | OF-2000 |
| CD 9314-9 FDDI-LCF             |                           | 7.0 (2.0)  |        |                             | OF-500  |         | OF-500  |         | OF-500  |         |
| ISO/IEC 9314-3 FDDI            |                           | 11.0 (6.0) |        |                             | OF-2000 |         | OF-2000 |         | OF-2000 |         |
| ISO/IEC DIS 9314-4 FDDI        |                           |            | 10.0   |                             |         |         |         |         |         | OF-2000 |
| ISO/IEC 8802-3: 100BASE-FX     |                           | 11.0 (6.0) |        |                             | OF-2000 |         | OF-2000 |         | OF-2000 |         |
| ATM-155                        | 7.2                       | 10.0 (5.3) | 7.0    | OF-500                      | OF-2000 | OF-500  | OF-2000 | OF-500  | OF-2000 | OF-2000 |
| ATM-622                        | 4.0                       | 6.0 (2.0)  | 7.0    | OF-500                      | OF-500  | OF-500  | OF-500  | OF-500  |         |         |
| CD 14165-1: Fibre Channel-133  |                           | 6.0        |        |                             | OF-2000 |         | OF-2000 |         | OF-2000 |         |
| CD 14165-1: Fibre Channel-266  | 12.0                      | 6.0 (5.5)  | 6.0    | OF-2000                     | OF-2000 | OF-2000 | OF-2000 | OF-2000 | OF-2000 | OF-2000 |
| CD 14165-1: Fibre Channel-531  | 8.0                       |            | 14.0   | OF-500                      |         | OF-500  |         | OF-500  |         | OF-2000 |
| CD 14165-1: Fibre Channel-1062 | 4.0                       |            | 6.0    | OF-500                      |         | OF-500  |         | OF-500  |         | OF-2000 |
| IEEE 802-3: 1000BASE-SX        | 2.6 (3.56)                |            |        | OF-300                      |         | OF-500  |         | OF-500  |         |         |
| IEEE 802-3: 1000BASE-LX        |                           | 2.35       | 5.0    |                             | OF-500  |         | OF-500  |         | OF-500  | OF-2000 |
| IEEE 802-3: 10000BASE-SX       | ?                         |            |        | OF-300                      |         | OF-500  |         | OF-500  |         |         |
| IEEE 802-3: 10000BASE-LX       |                           | ?          | ?      |                             |         |         |         | OF-300  |         | OF-2000 |

Note: the figures in brackets are the application optical power budget values for 50/125 (if they differ from that for 62.5/125)

# UK Fibreoptic Industry Association

Presentations 2000

## 2000 SERIES DOCUMENT SET

|                            |                  |  |
|----------------------------|------------------|--|
| <b>DESIGN</b>              | FIA-TSD-2000-1-1 | OPTICAL FIBRE CABLING: LAN APPLICATION SUPPORT GUIDE       |
| <b>COMPONENT SELECTION</b> | FIA-TSD-2000-2-1 | OPTICAL FIBRE CABLING: CABLE SELECTION GUIDE               |
|                            | FIA-TSD-2000-2-2 | OPTICAL FIBRE CABLING: CONNECTING HARDWARE SELECTION GUIDE |
| <b>OPERATION</b>           | FIA-TSD-2000-3-1 | OPTICAL FIBRE CABLING: QUALITY ASSURANCE                   |
|                            | FIA-TSD-2000-3-2 | OPTICAL FIBRE CABLING: ADMINISTRATION                      |
| <b>INSTALLATION</b>        | FIA-TSD-2000-4-1 | OPTICAL FIBRE CABLING: INSTALLATION PRACTICE               |
|                            | FIA-TSD-2000-4-2 | OPTICAL FIBRE CABLING: TESTING                             |
| <b>SAFETY</b>              | FIA-TSD-2000-5-1 | OPTICAL POWER: SAFETY LEVELS                               |
|                            | FIA-TSD-2000-5-2 | OPTICAL FIBRE: HANDLING OF PROCESSING CHEMICALS            |
|                            | FIA-TSD-2000-5-3 | OPTICAL FIBRE: DISPOSAL OF WASTE                           |

# Optical Power Budget - I

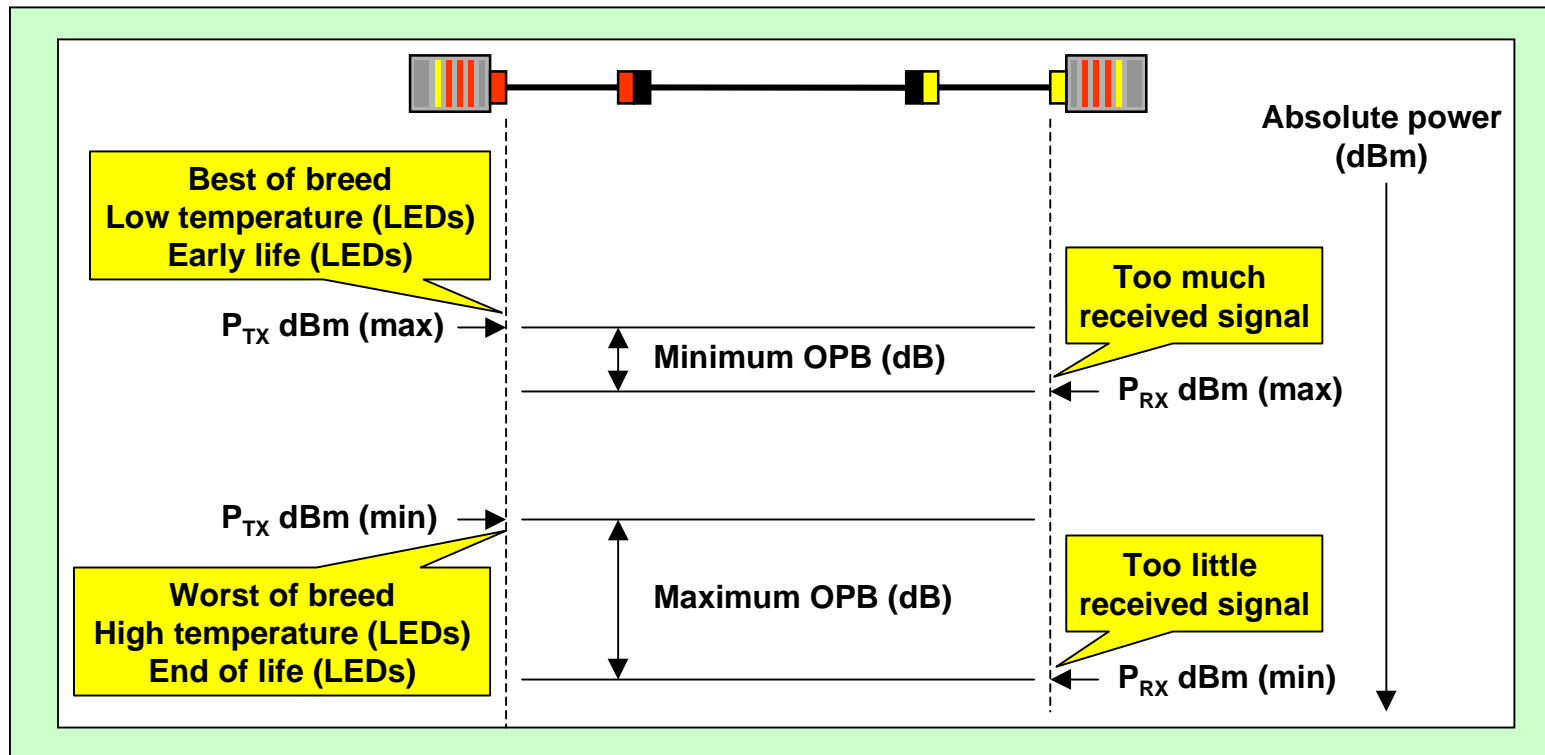

# Coupling Loss

Presentations 2000

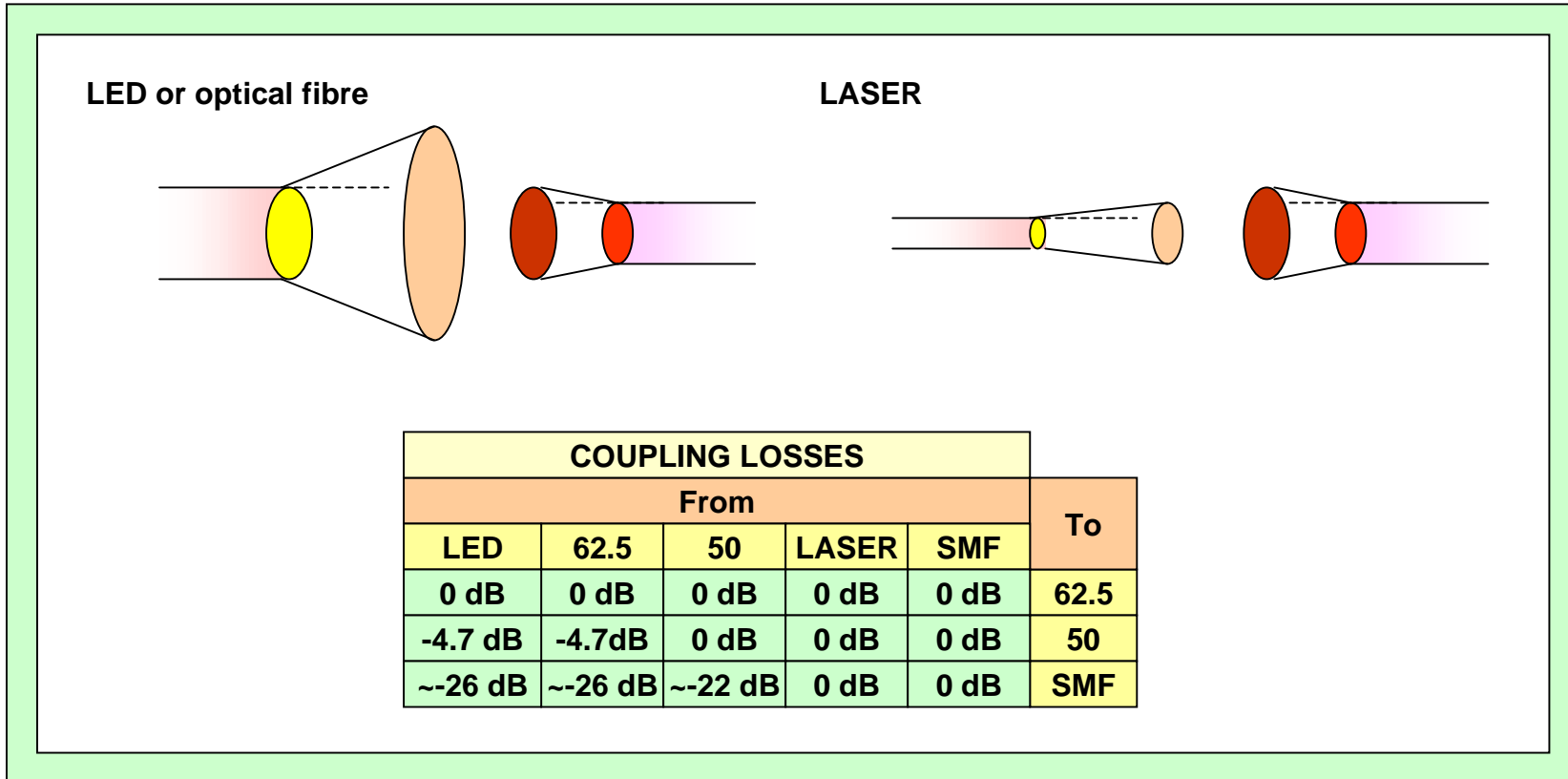

# Optical Power Budget - 1GbE

Presentations 2000

|  | 850nm    |      |        |      | 1300nm   |        |     | 1310nm |
|--|----------|------|--------|------|----------|--------|-----|--------|
|  | 62.5/125 |      | 50/125 |      | 62.5/125 | 50/125 |     | SMF    |
| OFL Modal Bandwidth (MHz.km)                 | 160      | 200  | 400    | 500  | 500      | 400    | 500 |        |
| Assumed OF attenuation (dBkm <sup>-1</sup> ) | 3.75     | 3.75 | 3.50   | 3.50 | 1.5      | 1.5    | 1.5 | 0.5    |

|                |   | 1000BASE-SX |      |      |      | 1000BASE-LX |      |      |            |
|----------------|---|-------------|------|------|------|-------------|------|------|------------|
|                |   | 830nm       |      |      |      | 1270nm      |      |      | 1270nm     |
| <b>A</b>       | Max. channel length (m)                   | 220         | 275  | 500  | 550  | 550         | 550  | 550  | 5000       |
|                | Max. OF cable attenuation (dB)            | 0.88        | 1.1  | 1.87 | 2.06 | 0.85        | 0.85 | 0.85 | 3.07       |
|                | Connecting hardware allowance (dB)        | 1.5         | 1.5  | 1.5  | 1.5  | 1.5         | 1.5  | 1.5  | 1.5        |
| <b>B</b>       | Total channel loss at maximum length (dB) | 2.38        | 2.60 | 3.37 | 3.56 | 2.35        | 2.35 | 2.35 | 4.57       |
| <b>C</b>       | Equipment OPB (dB)                        | <b>7.5</b>  |      |      |      | <b>7.5</b>  |      |      | <b>8.0</b> |
| <b>D</b>       | Power penalty (dB)                        | 4.27        | 4.29 | 4.07 | 3.57 | 3.48        | 5.08 | 3.96 | 3.27       |
| <b>B</b>       | Total channel loss (dB)                   | 2.38        | 2.60 | 3.37 | 3.56 | 2.35        | 2.35 | 2.35 | 4.57       |
| <b>E=C-D-B</b> | Unallocated margin (dB)                   | 0.84        | 0.60 | 0.05 | 0.37 | 1.67        | 0.07 | 1.19 | 0.16       |
| <b>B</b>       | Max. channel loss (IEEE defined) (dB)     | 2.38        | 2.60 | 3.37 | 3.56 | 2.35        | 2.35 | 2.35 | 4.57       |
| <b>B+E</b>     | Maximum channel loss inc. UM (dB)         | 3.22        | 3.2  | 3.42 | 3.93 | 4.02        | 2.42 | 3.54 | 4.73       |
| <b>A</b>       | Max. channel length (m)                   | 220         | 275  | 500  | 550  | 550         | 550  | 550  | 5000       |

# Attenuation Coefficient Variation

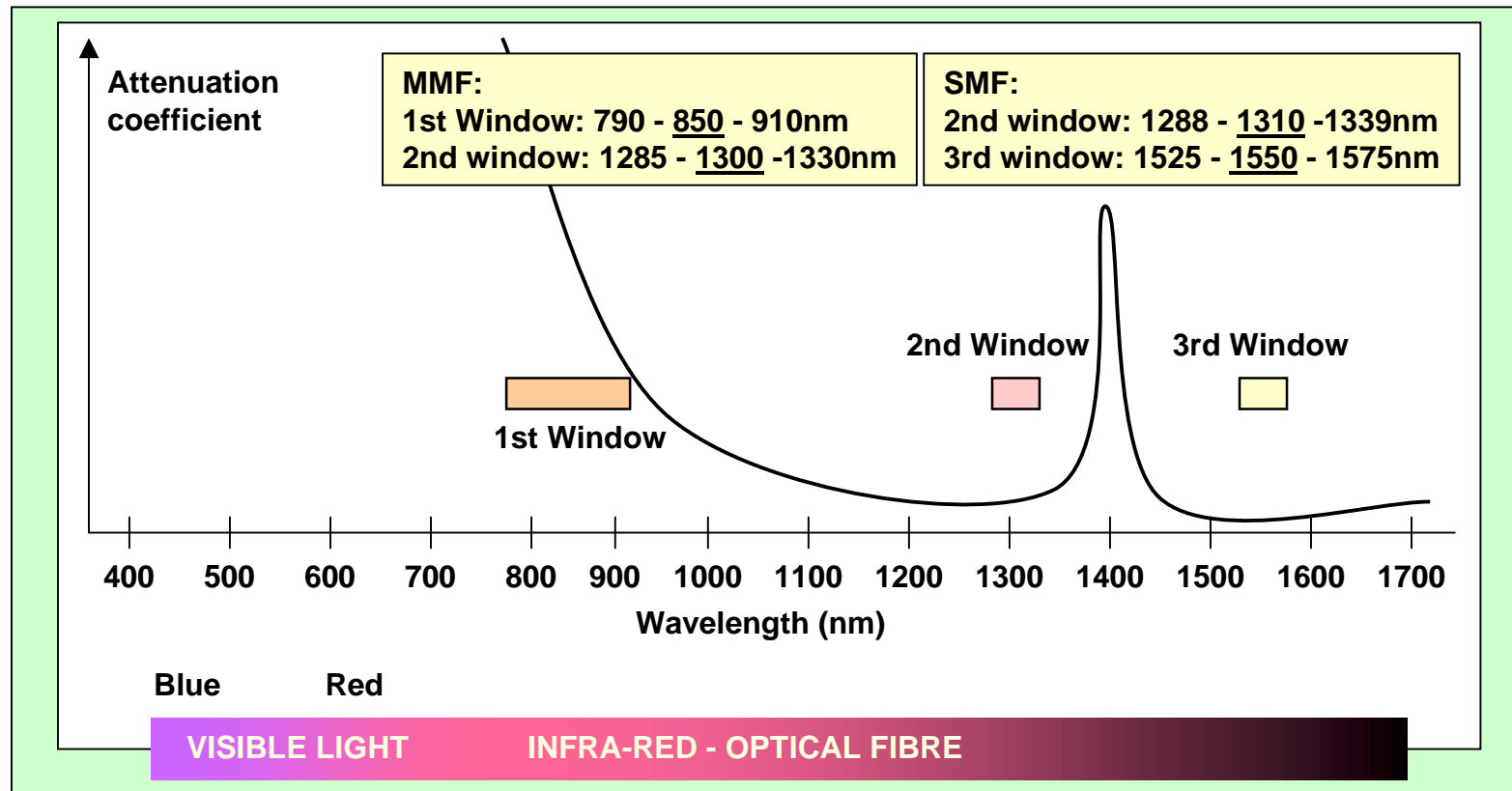

# Application-specific Channel Lengths

Presentations 2000

| APPLICATION                    | Optical power budget (dB) |            |        | Max. channel lengths (m) |                  |                  |                  |        |
|--------------------------------|---------------------------|------------|--------|--------------------------|------------------|------------------|------------------|--------|
|                                |                           |            |        | OF specification         |                  |                  |                  |        |
|                                | MMF                       |            | SMF    | OM1                      |                  | OM2              |                  | OS1    |
|                                | 850nm                     | 1300nm     | 1310nm | 62.5/125                 |                  | 50/125           |                  | 1310nm |
|                                |                           |            | 850nm  | 1300nm                   | 850nm            | 1300nm           | 1310nm           |        |
| ISO/IEC 8802-3: FOIRL          | 9.0 (3.3)                 |            |        | 1000                     |                  | 1000             |                  |        |
| ISO/IEC 8802-3: 10BASE-FL/FB   | 12.5 (6.8)                |            |        | 2000                     |                  | 2000             |                  |        |
| ISO/IEC 8802-5: TR 4/16 Mbit/s | 13.0 (8.0)                |            |        | 2000                     |                  | 2000             |                  |        |
| IEEE 802-12: Demand priority   | 7.5 (2.8)                 | 7.0 (2.3)  |        | 500                      | 2000             | 500              | 2000             | 2000   |
| ATM-52                         |                           | 10.0 (5.3) | 10.0   |                          | 2000             |                  | 2000             |        |
| CD 9314-9 FDDI-LCF             |                           | 7.0 (2.0)  |        |                          | 500              |                  | 500              |        |
| ISO/IEC 9314-3 FDDI            |                           | 11.0 (6.0) |        |                          | 2000             |                  | 2000             |        |
| ISO/IEC DIS 9314-4 FDDI        |                           |            | 10.0   |                          |                  |                  |                  | 2000   |
| ISO/IEC 8802-3: 100BASE-FX     |                           | 11.0 (6.0) |        |                          | 2000             |                  | 2000             |        |
| TR 100 Mbit/s                  |                           | 11.0 (6.0) |        |                          | 2000             |                  | 2000             |        |
| ATM-155                        | 7.2                       | 10.0 (5.3) | 7.0    | 1000 <sup>1</sup>        | 2000             | 1000             | 2000             | 2000   |
| ATM-622                        | 4.0                       | 6.0 (2.0)  | 7.0    | 300 <sup>1</sup>         | 500              | 300              | 500              | 2000   |
| CD 14165-1: Fibre Channel-133  |                           | 6.0        |        |                          | 1500             |                  |                  |        |
| CD 14165-1: Fibre Channel-266  | 12.0                      | 6.0 (5.5)  | 6.0    | 500                      | 1500             | 2000             | 2000             | 2000   |
| CD 14165-1: Fibre Channel-531  | 8.0                       |            | 14.0   | 350                      |                  | 1000             |                  | 2000   |
| CD 14165-1: Fibre Channel-1062 | 4.0                       |            | 6.0    | 300 <sup>1</sup>         |                  | 500 <sup>1</sup> |                  | 2000   |
| IEEE 802-3: 1000BASE-SX        | 2.6 (3.56)                |            |        | 275 <sup>1</sup>         |                  | 550 <sup>1</sup> |                  |        |
| IEEE 802-3: 1000BASE-LX        |                           | 2.35       | 5.0    |                          | 550 <sup>1</sup> |                  | 550 <sup>1</sup> | 2000   |

Note 1: these applications are bandwidth limited - lower attenuation channels do not guarantee longer lengths.  
Note: the figures in brackets are the application optical power budget values for 50/125 (if they differ from that for 62.5/125)

# FIA Implementation Rules

Presentations 2000

|            |                                 | Maximum channel length L (metres)<br>(subject to limits defined by application standard) |   |
|------------|---------------------------------|--|---|
|            |                                 | $\lambda = 850 \text{ nm}$   | $\lambda = 1300 \text{ nm}$                     |
| Multimode  | Cable Category<br>OM1, OM2, OM3 | $L = (1000 \cdot \text{OPB}/3.5) - 145x - 90y$   | $L = (1000 \cdot \text{OPB}/1.5) - 330x - 200y$ |
|            |                                 | $L = (1000 \cdot \text{OPB}/1.0) - 500x - 300y$  | $L = (1000 \cdot \text{OPB}/1.0) - 500x - 300y$ |
| Singlemode | OS1                             | $\lambda = 1310 \text{ nm}$  | $\lambda = 1550 \text{ nm}$                     |
|            |                                 | $L = (1000 \cdot \text{OPB}/1.0) - 500x - 300y$  | $L = (1000 \cdot \text{OPB}/1.0) - 500x - 300y$ |

Where:  
x = no. of mated connections in the channel  
y = no. of splices in the channel

|   |  |  |
|---|--|--|
| 0.5dB = 145m of 3.5dBkm <sup>-1</sup> cable<br>0.3dB = 90m of 3.5dBkm <sup>-1</sup> cable | 0.5dB = 330m of 1.5dBkm <sup>-1</sup> cable<br>0.3dB = 200m of 1.5dBkm <sup>-1</sup> cable | 0.5dB = 500m of 1.0dBkm <sup>-1</sup> cable<br>0.3dB = 300m of 1.0dBkm <sup>-1</sup> cable |
|---|--|--|

# Optical Fibre Selection $\leq$ 1Gb/s

|               | Max. OLB (dB) |         | Optical fibre choices                               |               |
|---------------|---------------|---------|---|---------------|
|               | 850 nm        | 1300 nm |   |               |
| < 200 metres  | 2.3           | 1.3     | Either 50/125 <sup>1</sup> or 62.5/125 <sup>2</sup> | SMF > 1Gb/s   |
| < 500 metres  | 3.3           | 2.3     | 50/125 <sup>1</sup>                                 |               |
| < 1500 metres | 6.8           | 6.0     | 50/125  | SMF > 200Mb/s |
|               | 12.0          | 10.0    | 62.5/125 <sup>3</sup>                               |               |
| < 2000 metres | 6.8           | 6.0     | 50/125  |               |
|               | 12.0          | 10.0    | 62.5/125 <sup>3</sup>                               |               |

<sup>1</sup> 50/125: 3.5/1.5dBkm<sup>-1</sup>, 500/500MHz.km

<sup>2</sup> 62.5/125: 3.5/1.5dBkm<sup>-1</sup>, 200/500MHz.km preferred

<sup>3</sup> 62.5/125: 3.5/1.5dBkm<sup>-1</sup>, 200/500MHz.km adequate

# EN 50174 Standards

Presentations 2000

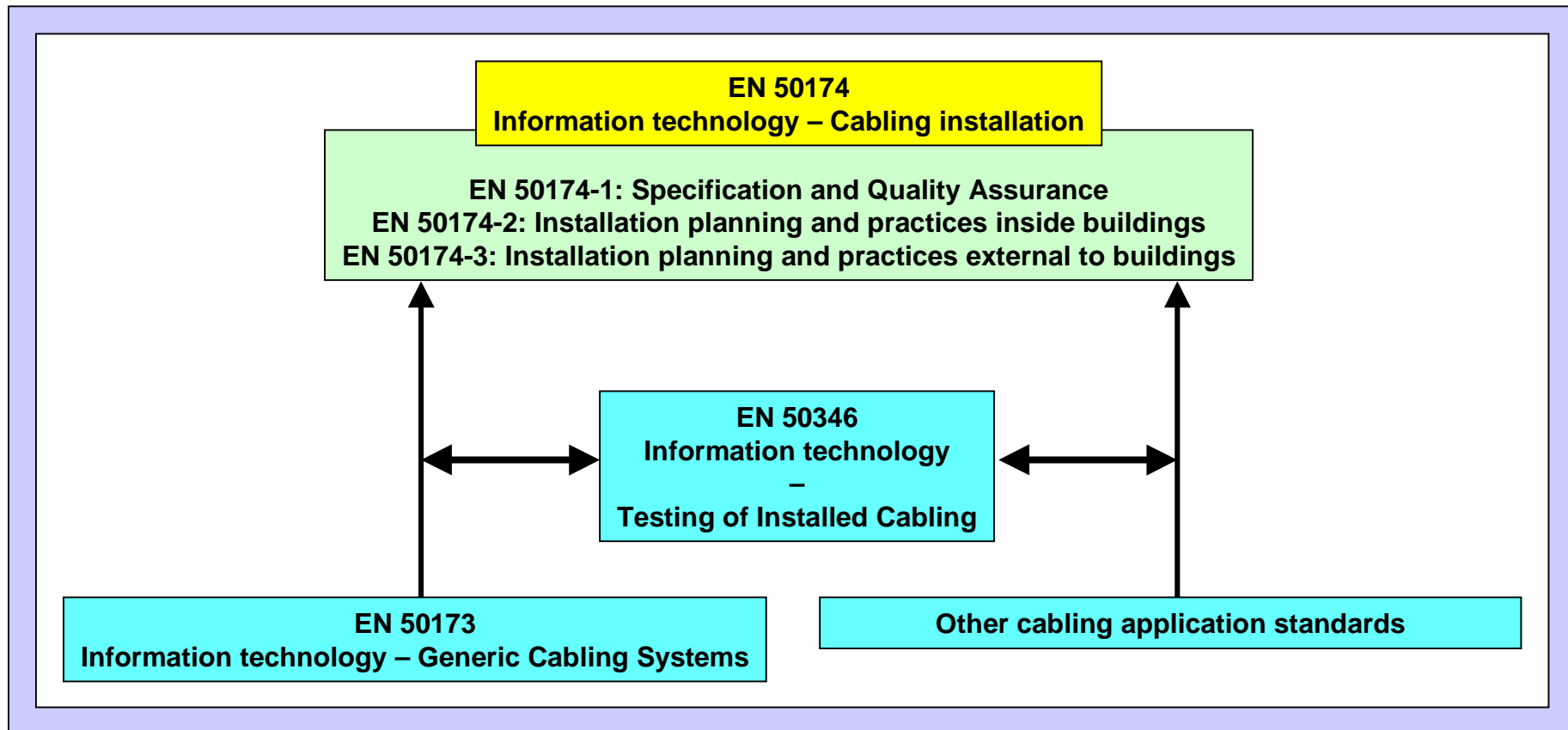

# The Impact of EN 50174

**BS EN 50174-1: Information technology – Cabling installation - Specification and Quality Assurance**

**BS EN 50174-2: Information technology – Cabling installation - Installation planning and practices inside buildings**

**Published 01/01**

**“In force” 08/01**

**BS 7718 - A Code of Practice for  
“Installation of Fibre Optic Cabling”**

**to be reviewed and possibly withdrawn**

**BS 7671**

**• The Wiring Regulations (IEE)**

**untouched**

# 10 Gb/s Ethernet: 802.3ae

## OBJECTIVES

- switched operation only
- star topology
- support 10Gb/s Ethernet and 9.584640Gb/s SONET
- 2000 m, 10000 m and 40000 m over SMF
- 100 m over existing MMF

## PROPOSALS FOR IMPLEMENTATION

### CURRENT

- legacy MMF (OM1, OM2)
  - 1300nm 4 channel parallel: 300 m
  - 1300nm single channel: 75 m
- legacy SMF (OS1)
  - 1310nm LASERS: 300 m to 10000 m
  - 1550nm LASERS: 40000 m

### FUTURE (maybe)

- legacy MMF (OM1, OM2)
  - 1300nm 4 x WDM: 300 m
- "new" MMF (OM-3)
  - 850nm VCSEL: 300m



# The End

- full colour copy of presentation
- [www.it-cabling.com/gendocs/gs-ittrends.pdf](http://www.it-cabling.com/gendocs/gs-ittrends.pdf)