

Trends in Business & IT Infrastructures

Mike Gilmore

Senior Partner, The Cabling Partnership and e-Ready Building
Chairman, BSI TCT7/-/1 and TCT7/-/3
Convenor CLC TC215 WG1
Technical Director, UK Fibreoptic Industry Association

improving communication



The Cabling Partnership

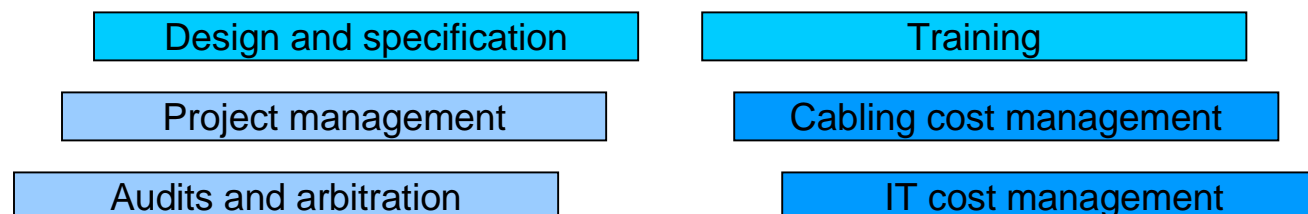

SERVICE PROVIDER
TO THE
INFORMATION TECHNOLOGY
CABLING MARKET

www.it-cabling.com

improving communication



Cabling Facing Recession

No reduction in business levels

Cabling Facing Recession

No reduction in business levels

Significant reduction in margins

Cabling Facing Recession

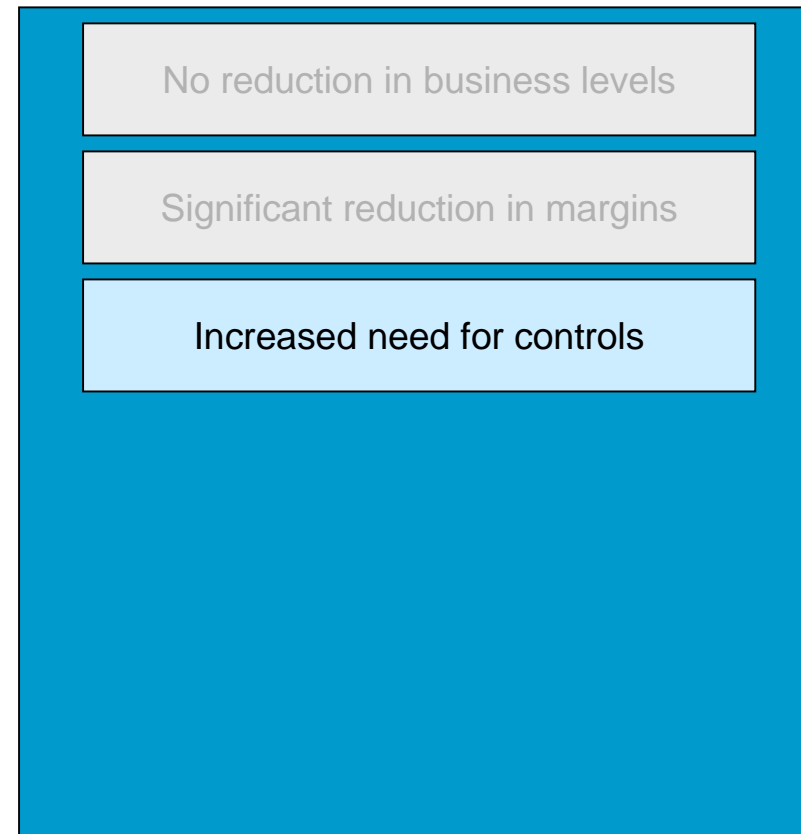

Cabling Facing Recession

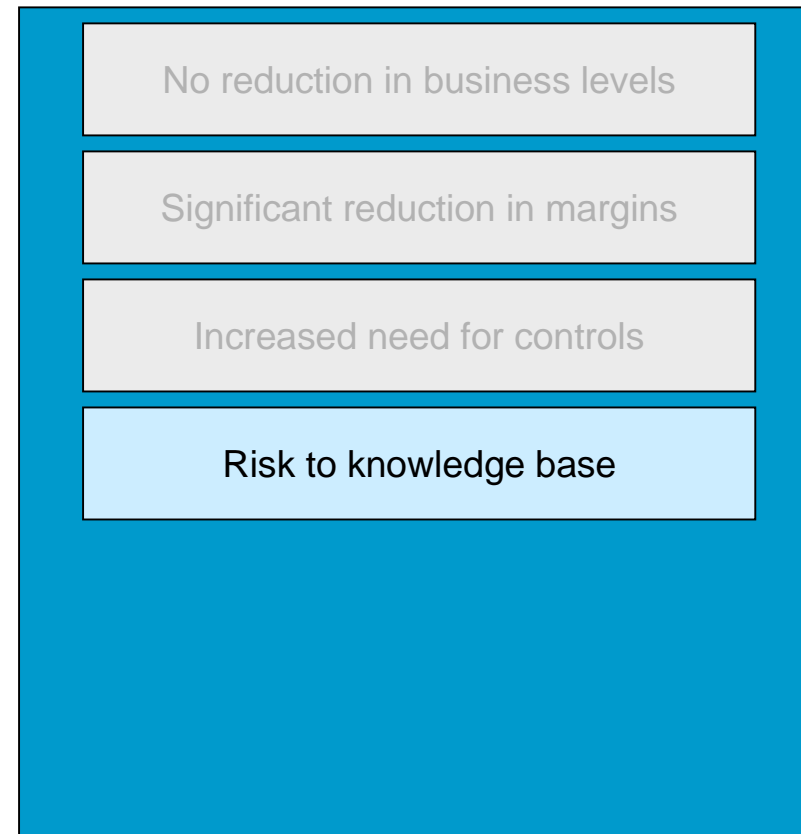

Cabling Facing Recession



Infrastructure Options

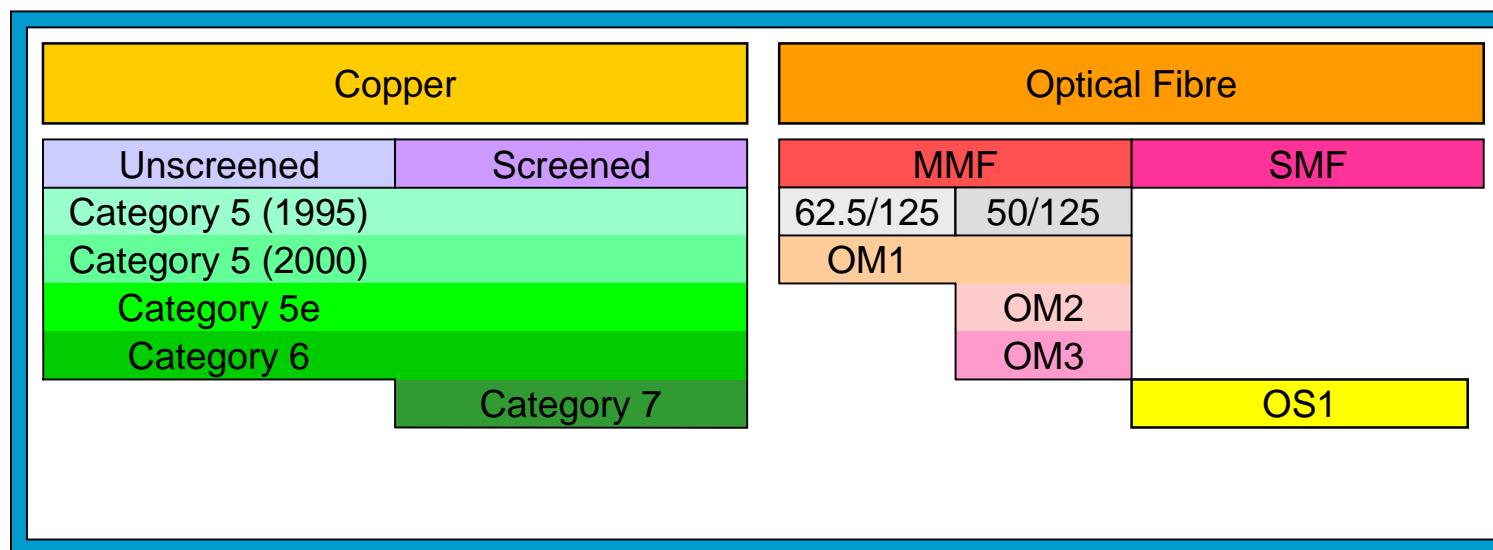

Application Development

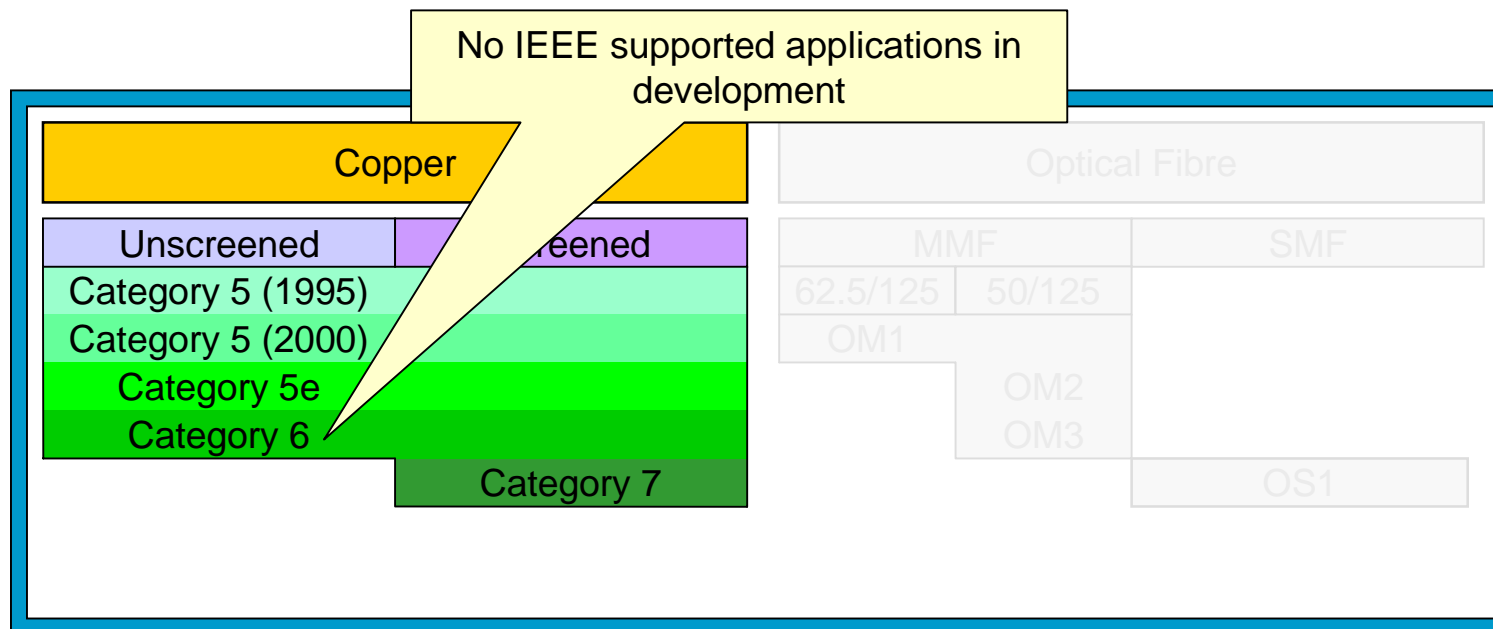

Application Development

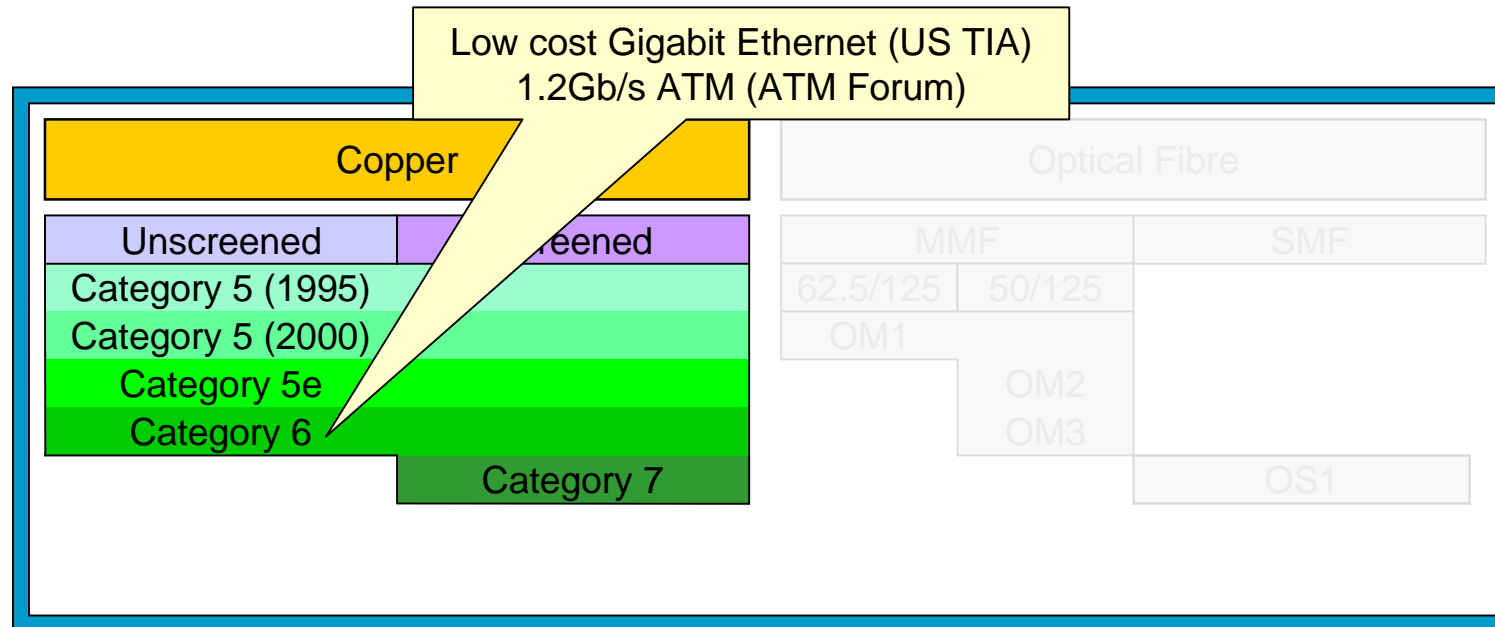

Application Development

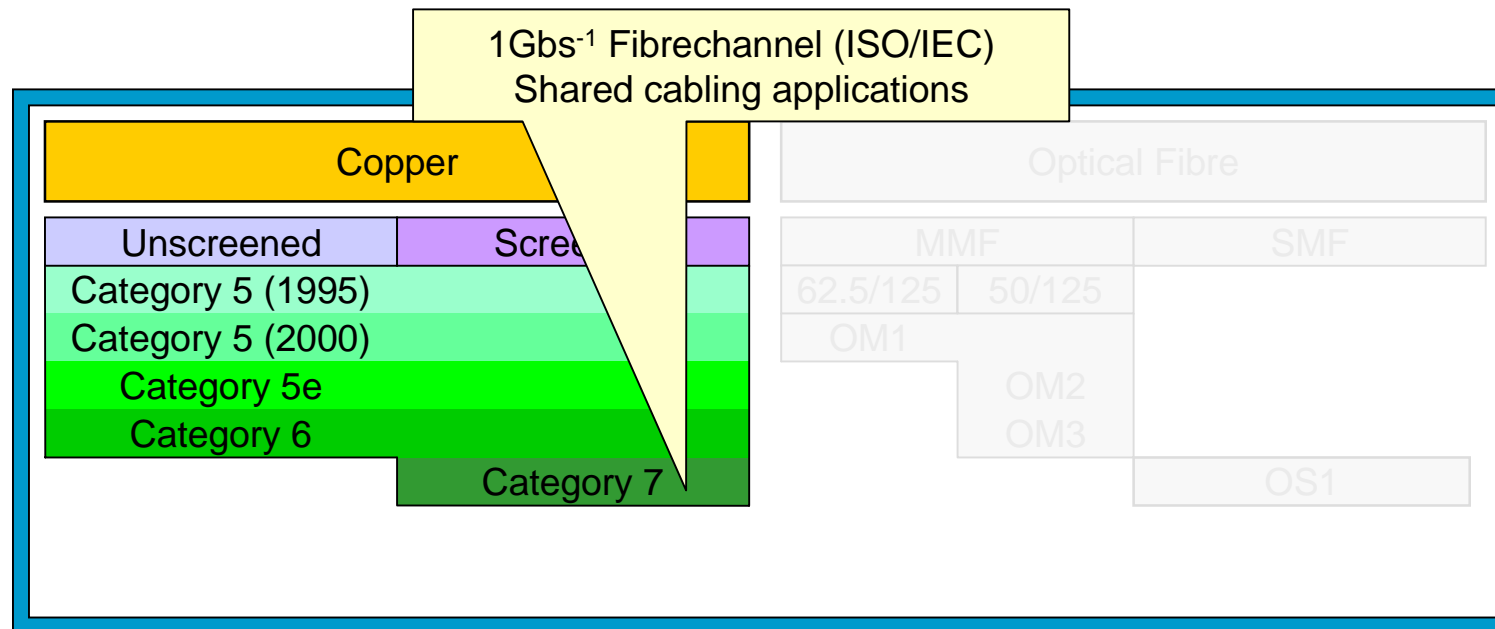

The Technology Squeeze

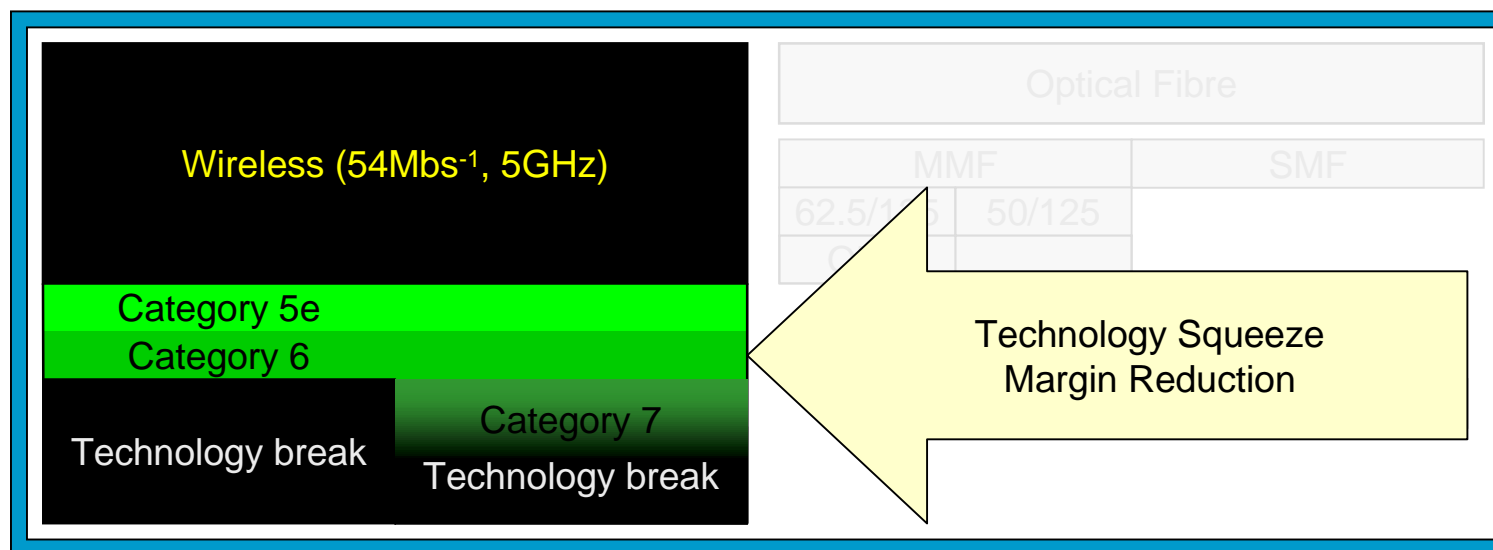

IEEE Activity - Copper

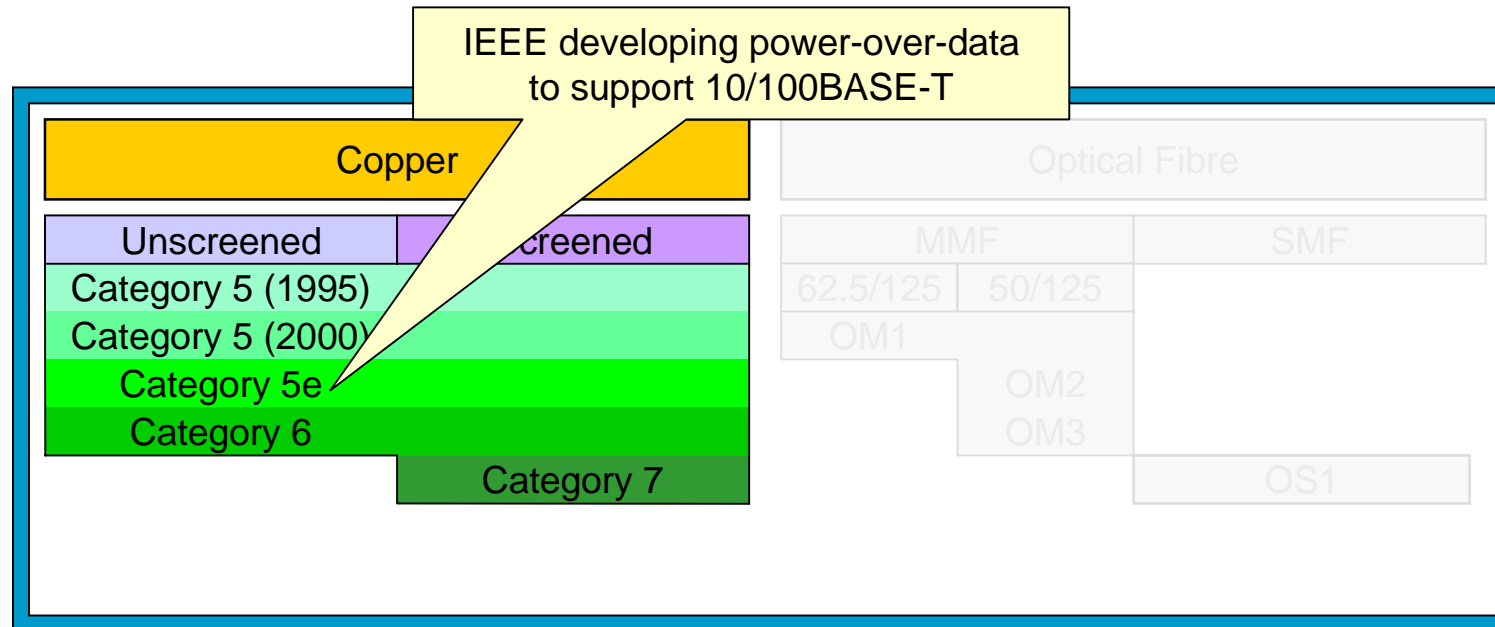

IEEE Activity - Optical Fibre

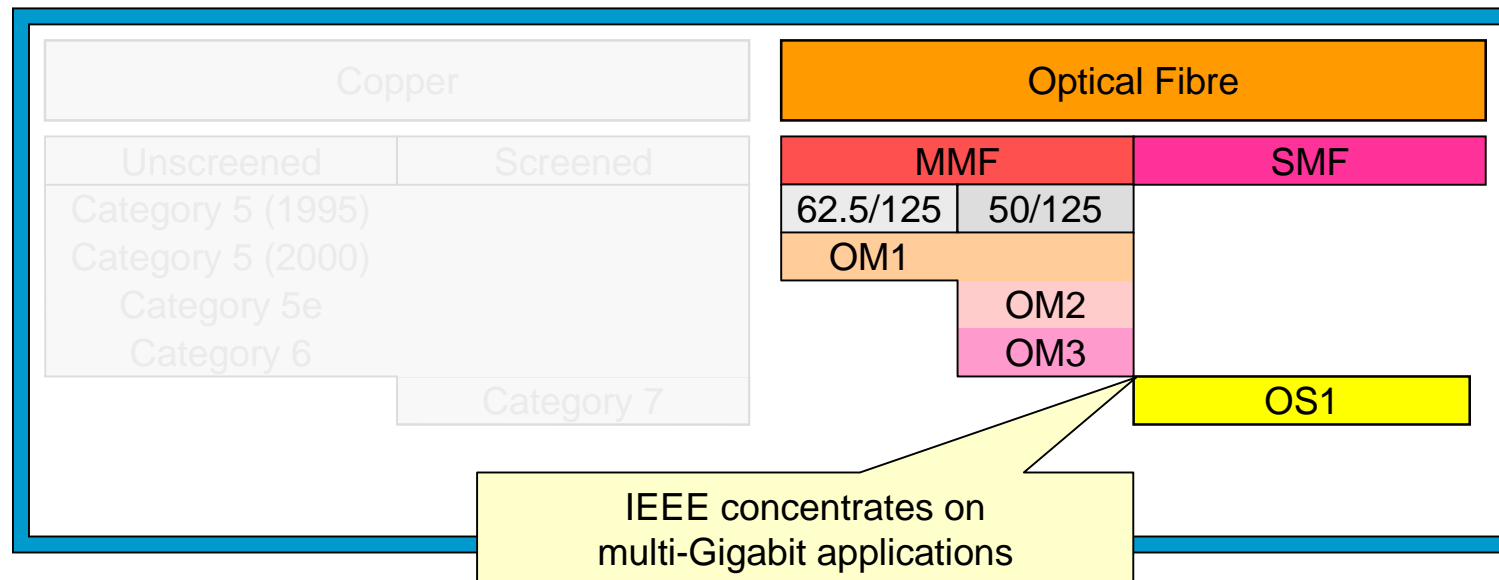

10GBASE-xx Implementation

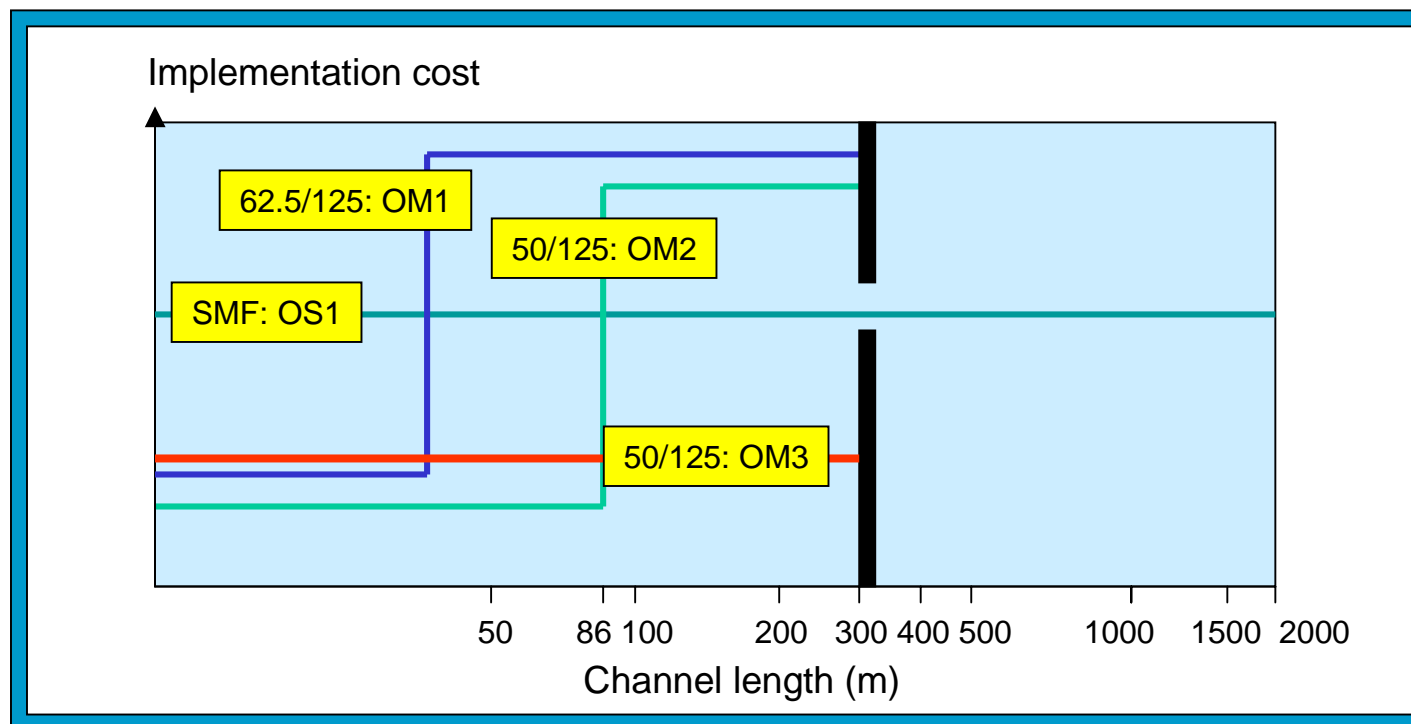

Category 8 - A Sideshow

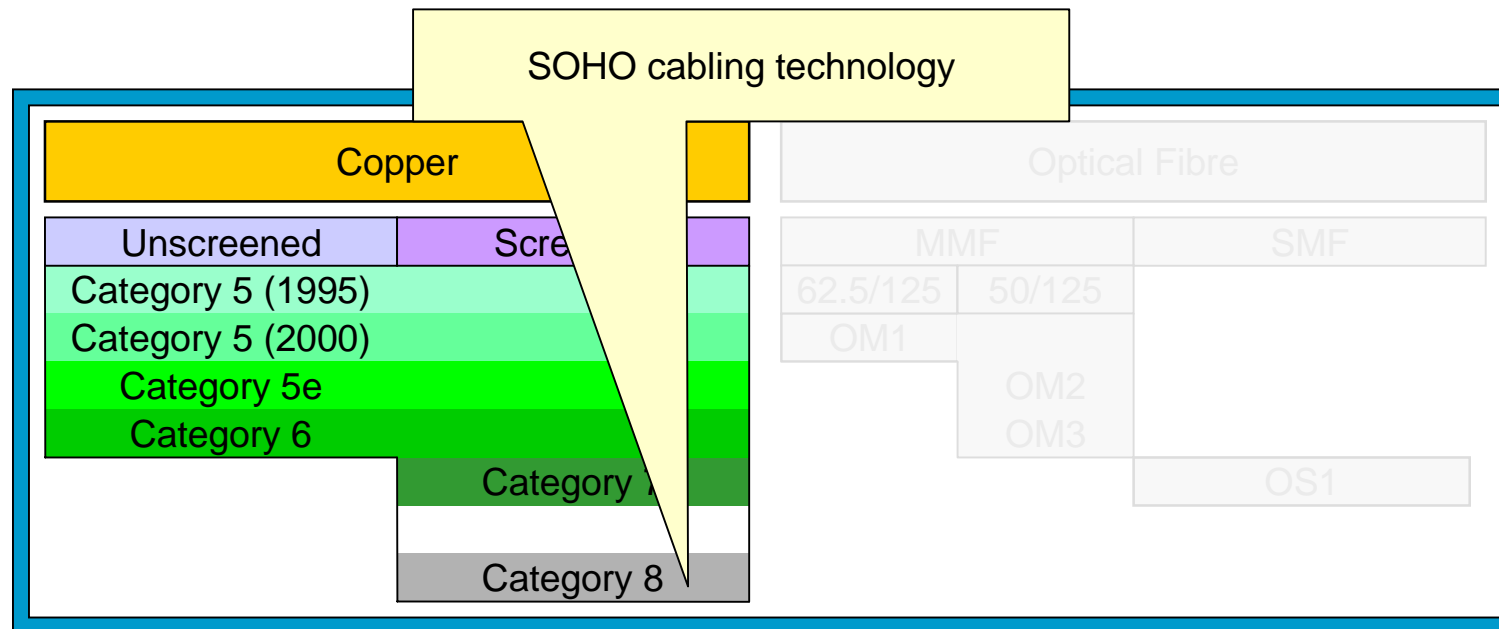

Next Generation Standards

EUROPE	EN 50173 Ed.2 (2002)	UNITED STATES	ANSI/TIA/EIA 568B
<ul style="list-style-type: none"> • 6MP begins • 3MV begins Q1, 2002 • publication 	<p>July, 2001</p> <p>Q3, 2002</p>	<ul style="list-style-type: none"> • 568B.1 General Requirements • 568B.2 Balanced Twisted-pair Cabling <ul style="list-style-type: none"> • Addendum 1 <ul style="list-style-type: none"> • Category 6 • Draft 8 (05/2001) • 568B.3 Optical Fibre Cabling 	
INTERNATIONAL	IS 11801 Ed.2 (2002)		
<ul style="list-style-type: none"> • CD • 2nd CD • FCD • FDIS • publication 	<p>Q4, 2000</p> <p>NOW</p> <p>Q4, 2001</p> <p>Q1, 2002</p> <p>Q3, 2002</p>		

“State of the Art” Technology

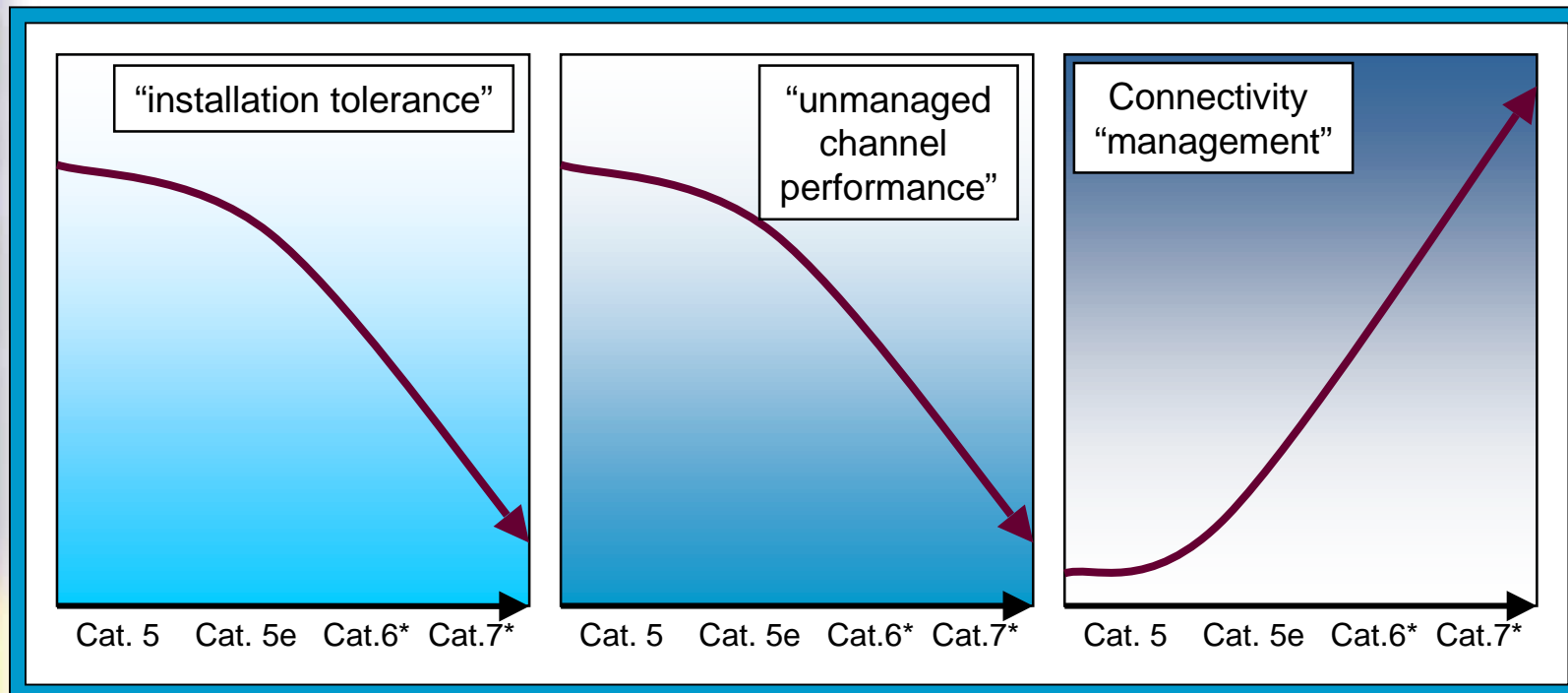

IT Futureworld

TREND	IMPACT	AFFECTING
IT cabling: a commodity	Low margin business	Suppliers - Installers
Applications: strategies defined	Fewer design choices	Consultants
<i>Competent</i> IT resource: shortfall	Cost of solutions provision	Users
<i>Competent</i> FM resource: shortfall	Cost of service provision	Users

IT Futureworld

TREND	IMPACT	AFFECTING
IT cabling: a commodity	Low margin business	Suppliers - Installers
Applications: strategies defined	Fewer design choices	Consultants
<i>Competent</i> IT resource: shortfall	Cost of solutions provision	Users
<i>Competent</i> FM resource: shortfall	Cost of service provision	Users

Network reliability
Cost of ownership

e-Ready Building

Pre-installed cabling infrastructure

A centrally-managed IT function

High-bandwidth external connections

e-readybuilding.com
RESOURCE
FOR
TENANTS AND PROPERTY DEVELOPERS

www.e-readybuilding.com

improving communication



Changing Environments

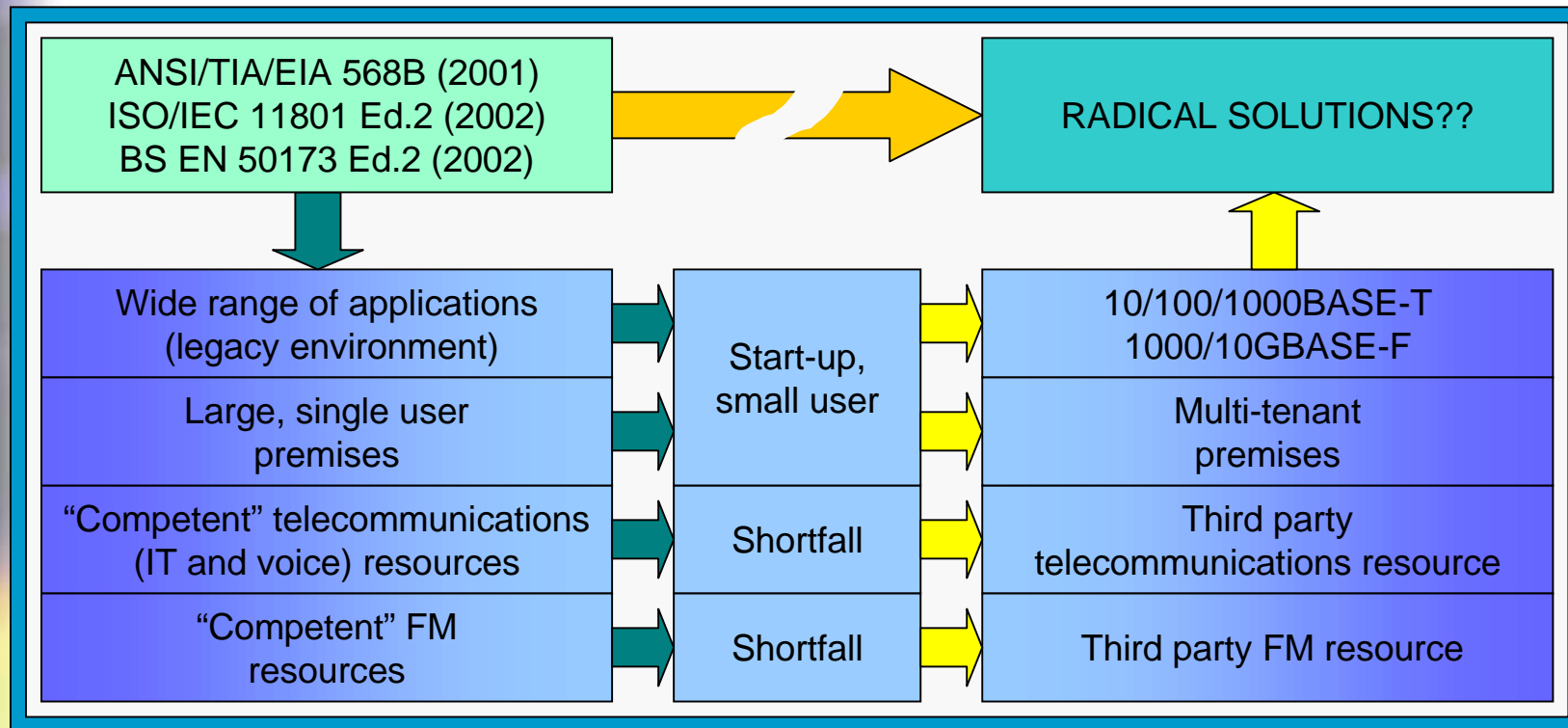

e-Ready Building

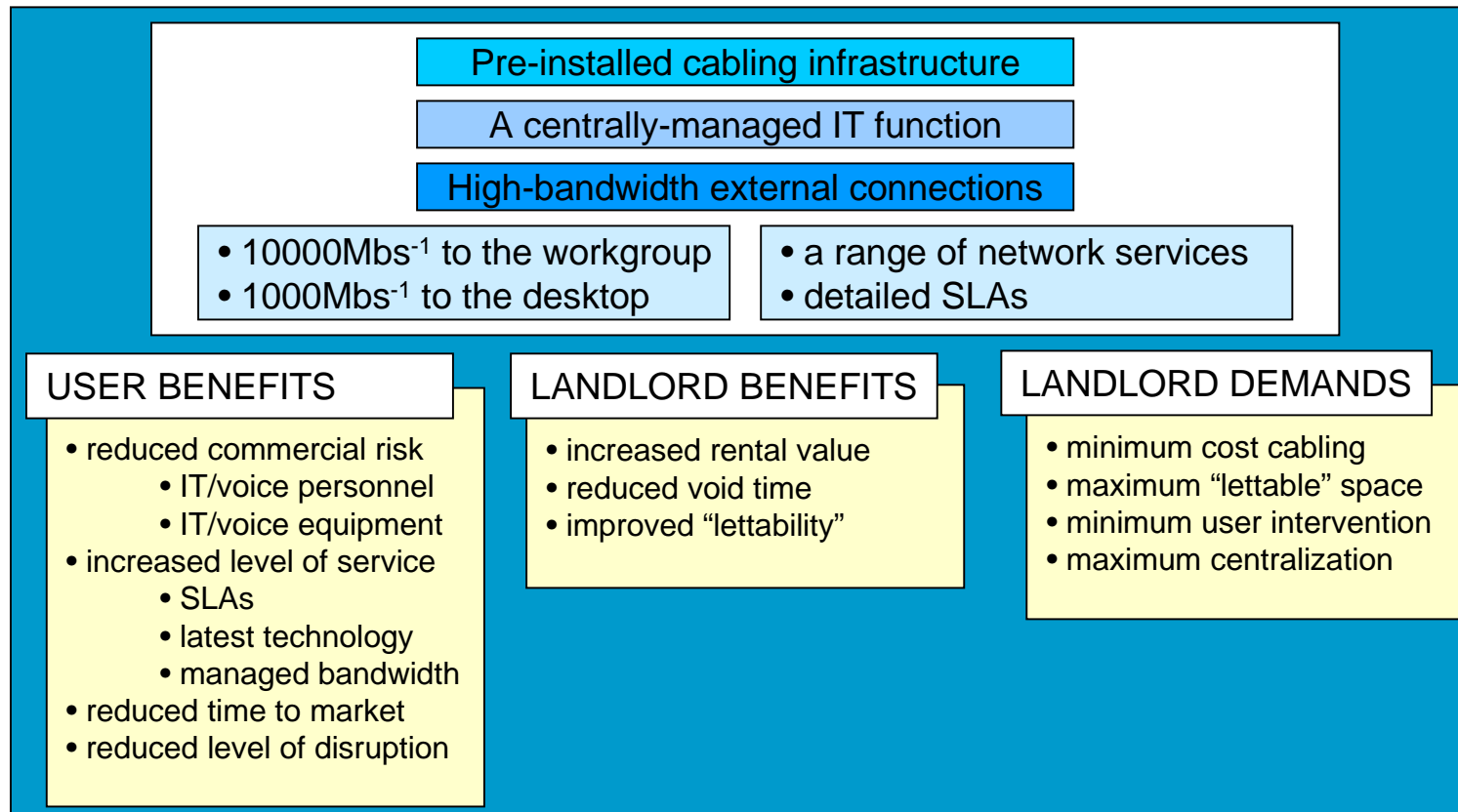

Conventional Structured Cabling

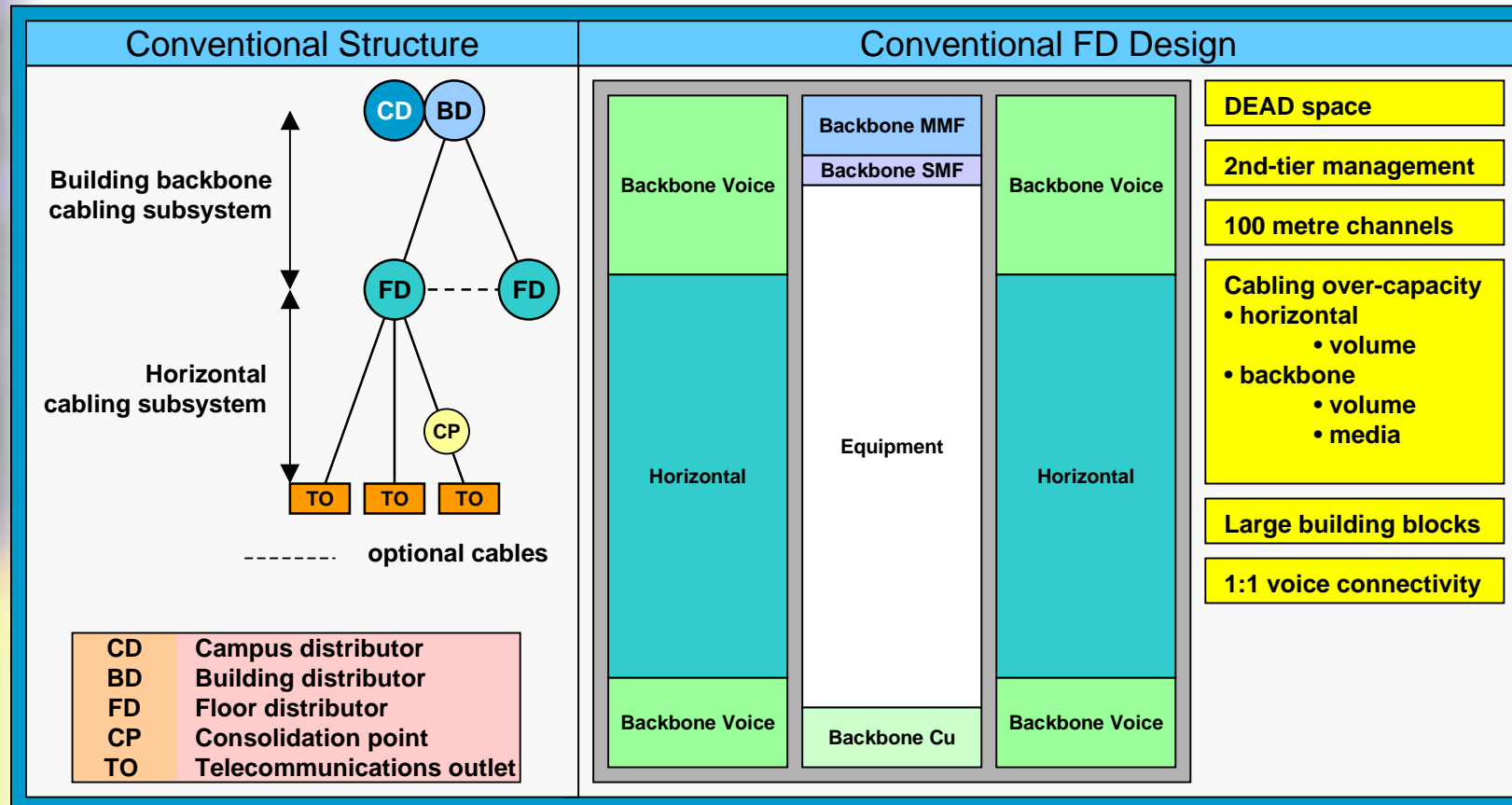

e-Ready Structured Cabling

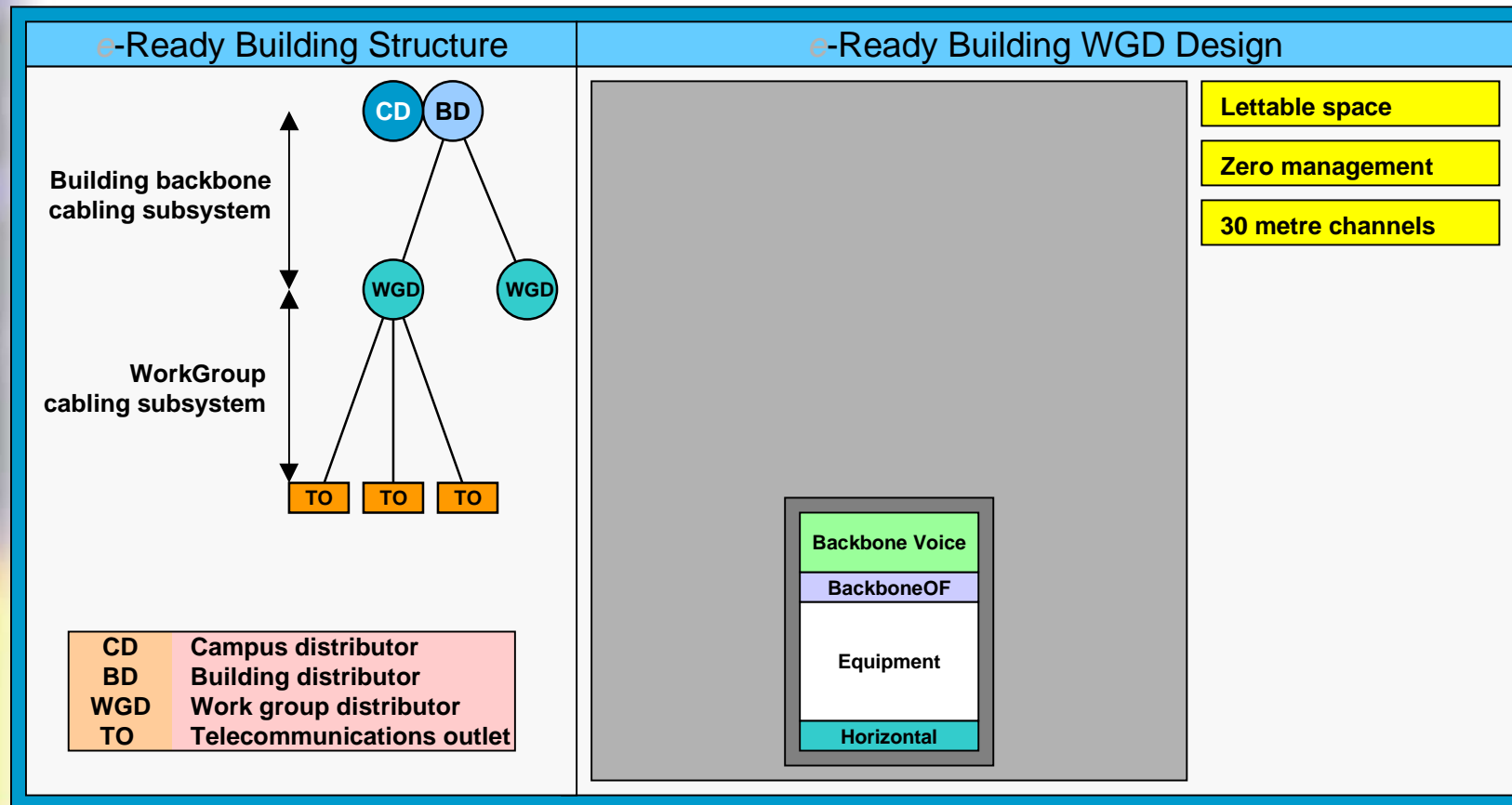

Conventional Cabling Channels

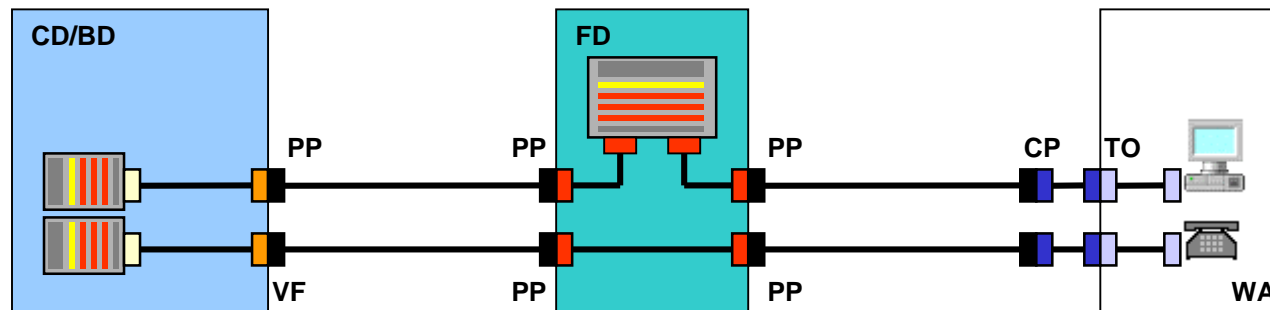

CD	Campus distributor	PP	Patch panel
BD	Building distributor	VF	Voice frame
FD	Floor distributor		
WGD	Work group distributor		
CP	Consolidation point		
TO	Telecommunications outlet		

e-Ready Cabling Channels

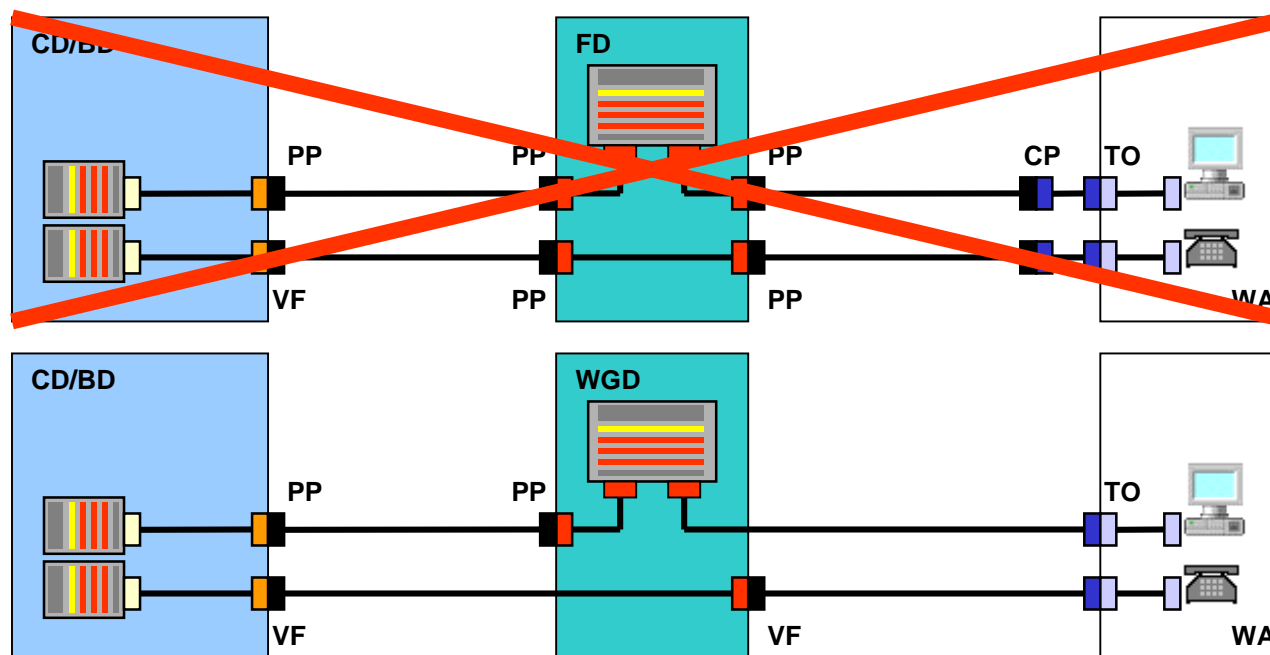

CD	Campus distributor	PP	Patch panel
BD	Building distributor	VF	Voice frame
FD	Floor distributor		
WGD	Work group distributor		
CP	Consolidation point		
TO	Telecommunications outlet		

improving communication

e-Ready Data Channels

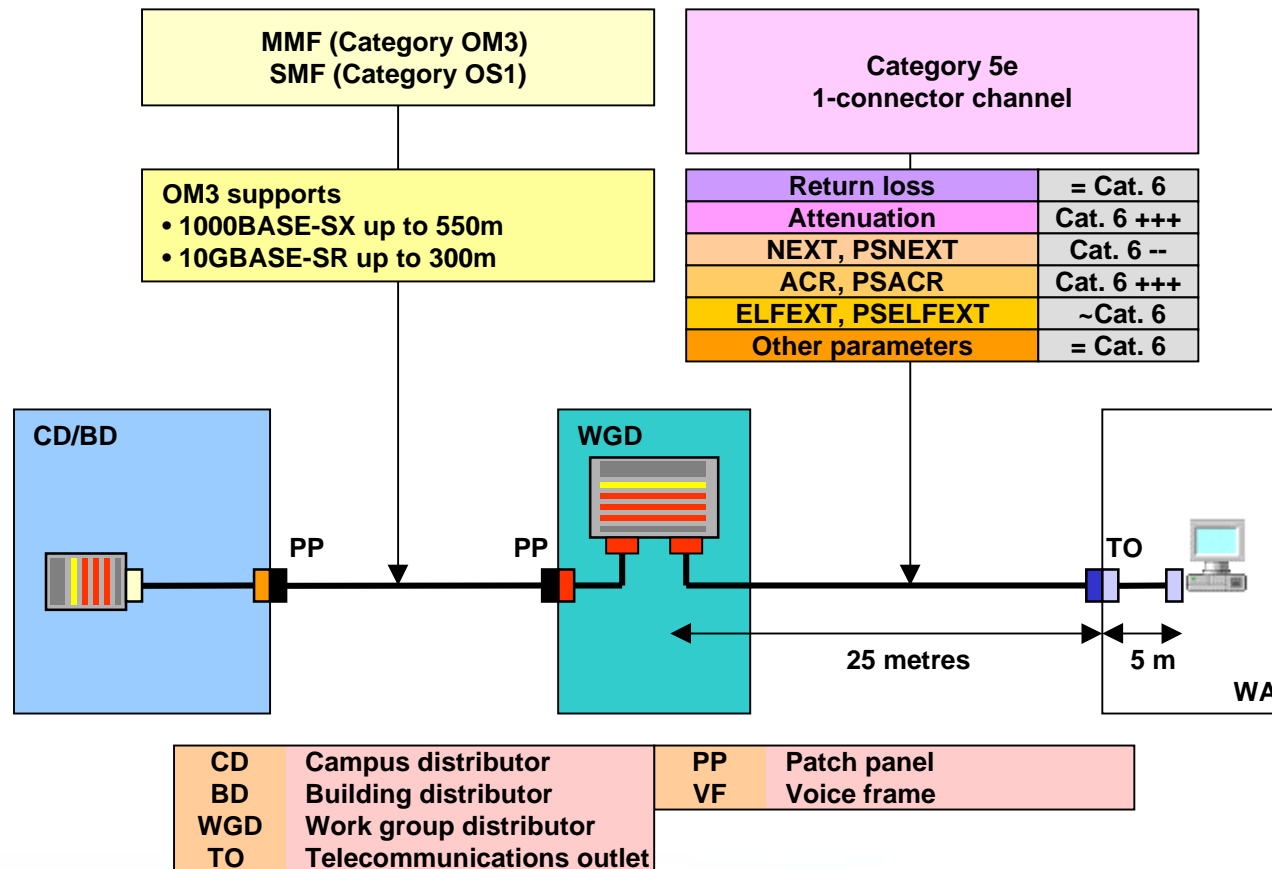

e-Ready Building Evolution

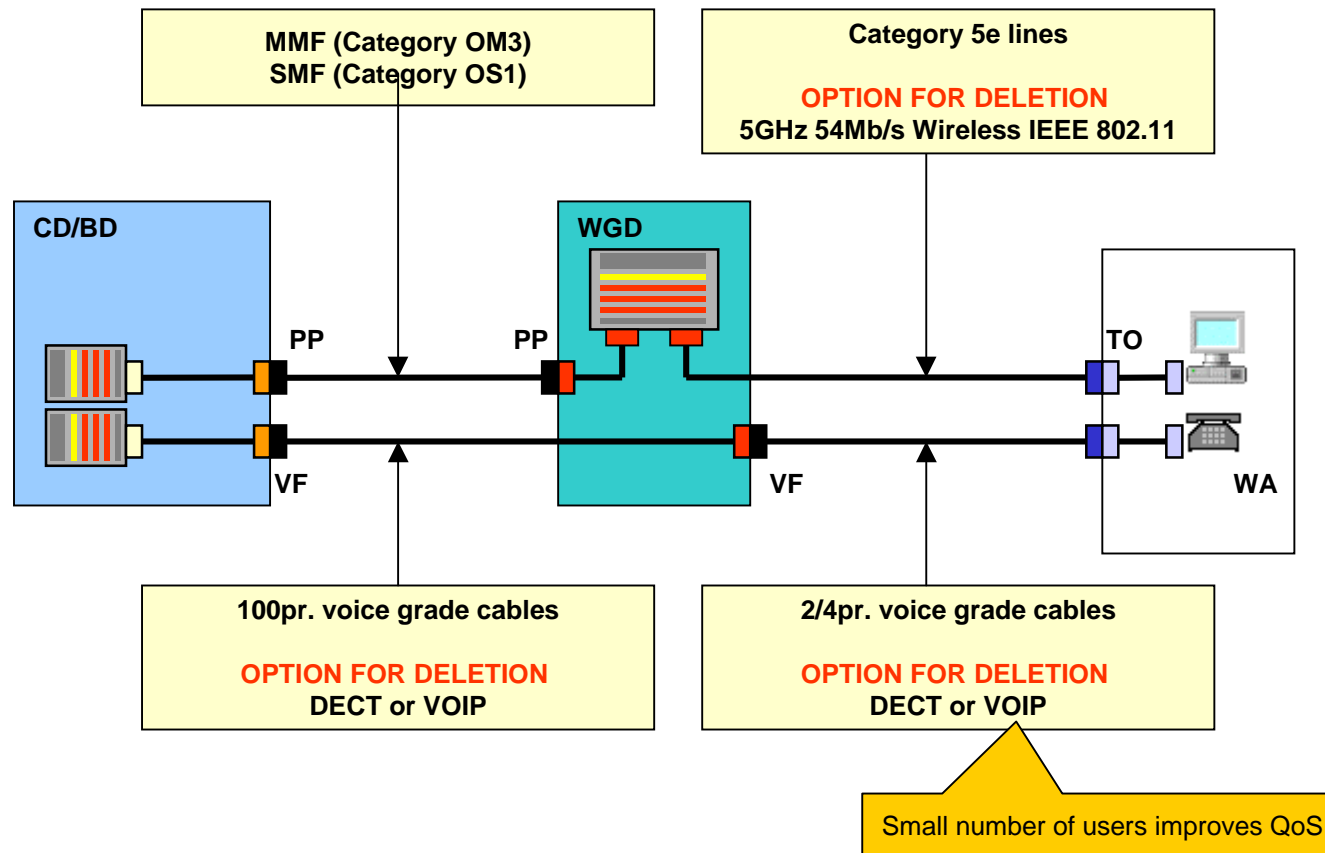

improving communication

Thank You

Mike Gilmore

www.it-cabling.com

www.e-readybuilding.com

improving communication

