

The author

Mike Gilmore, Senior Partner of The Cabling Partnership, is involved at the highest level in UK and European cabling standardisation. Mike is Chairman of the BSI Premises Cabling Experts Panels (TCT7/-/1 and TCT7/-/3) and Convenor of CENELEC TC215 Working Group 1 (its European partner). The two groups control the development of UK and European standards for the design and installation of telecommunications cabling. Mike also acts as the Technical Director of the UK Fibreoptic Industry Association. He can be contacted at mike.gilmore@btinternet.com.



The IT cabling infrastructure
division of
e-Ready Building Limited

The IT cabling consultants

e-Ready Building Limited
Next generation IT infrastructures

Paradigm shifts in ISO/IEC 11801 Ed.2 and EN 50173-1

Introduction

For many designers and installers the main aspects of the new cabling infrastructure standards will be the inclusion of Category 6 and Category 7 components for balanced cabling and the development of optical fibre cable Categories. My previous article reviewed the differences between the forthcoming second editions of ISO/IEC 11801, EN 50173-1 (the second edition of EN 50173) and the published ANSI/TIA/EIA-568B standards. It concentrated on copper (balanced) cabling Categories and Classes and identified some key differences between various specifications and standards. The article concluded that, provided that you defined which standard was being used, the difference were not earth-shattering.

This article, by comparison, covers a much more serious topic because a series of more subtle changes has been made to the foundations of the ISO/IEC and EN standards that undermines the simplistic implementation rules that are so often quoted (and misquoted).

Implementation rules are the cabling configurations (lengths, number of connections etc.) that have become the accepted norm for the "rule-of-thumb" designer. These rules have been the bedrock of the standards with maximum permanent link lengths of 90 metres and channels of 100 metres being the most obvious examples. The current understanding is that if "good" components are used and the implementation rules are followed then, to borrow a well-used phrase, "everything in the garden will be rosy". The changes made in the forthcoming editions of the standards explicitly affect this assumption.

The changes referred to above reflect the decision taken in Munich (September 1997) to define two new "state-of-the-art" balanced cabling solutions based upon what were to become Category 6 and Category 7 components. The problem with "state-of-the-art" technology is that it comes with an associated risk. In this case it is the risk that using the right components in the right configurations does not always guarantee the right result in terms of installed cabling performance.

This may have a significant impact on the designers, installers and user alike. The purpose of this article is to highlight these changes which may, at first sight, appear editorial but have serious implications for the unwary. This article reviews the specific impact of these fundamental changes on balanced cabling. Future articles will address optical fibre in more detail.

The existing "reference" implementations

The implementation rules of the existing standards provide a route to meeting the requirements of those standards by using compliant components, following the rules of link/channel length and not exceeding the specified number of connections. In the published editions of the ISO and EN standards these rules are very

The Cabling Partnership
P. O. Box MT 65, LEEDS, West Yorkshire, LS17 8YD, England
Telephone: +44 (0) 113 232 3721 Fax: +44 (0) 113 293 2632

The Cabling Partnership is a division of e-Ready Building Limited
Company Registration No. 4432595 Registered Office - Emery House, 192 Heaton Moor Road, Stockport, Cheshire, SK4 4DU.

straightforward and relate Class D link/channel performance to the Category 5 component set of those standards (see Figure 1).

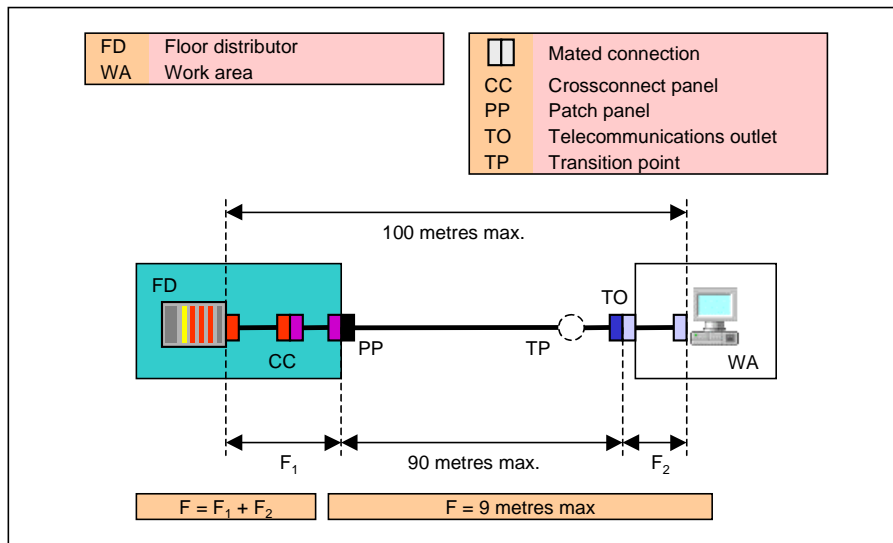

Figure 1: "Reference" implementation of the current standards

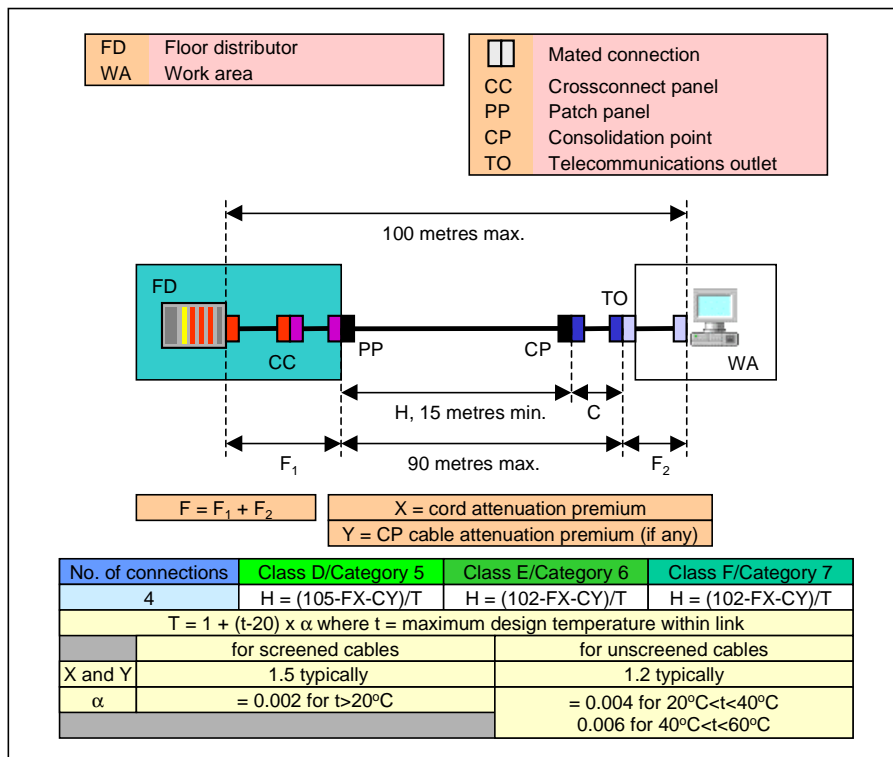

Figure 2: The reference implementations of ISO/IEC 11801 Ed.2 and EN 50173-1

The maximum length of 100 metres for a channel is clearly marked as is the 90 metres for the permanent link. Not many readers will have picked up the apparent anomaly of the 9 metres allocated to cords that suggests that you cannot have a 100 metre channel containing three connections. However, there is a get out clause that allows the 10 metres of cordage providing that you only have two connections (i.e. no cross-connect panel). This generally unrecognised "connection-dependent" length rule represents the basis of the new reference implementations in the second editions of the standards.

The new "reference" implementations

Figure 2 shows the new reference implementations for balanced cabling. These are now so complex that they cannot be contained within a relatively simple diagram as in Figure 1. They also need a series of

The Cabling Partnership
 P. O. Box MT 65, LEEDS, West Yorkshire, LS17 8YD, England
 Telephone: +44 (0) 113 232 3721 Fax: +44 (0) 113 293 2632

The Cabling Partnership is a division of e-Ready Building Limited
 Company Registration No. 4432595 Registered Office - Emery House, 192 Heaton Moor Road, Stockport, Cheshire, SK4 4DU.

equations providing great detail as to how to create Class D (2002), Class E and Class F channels from Category 5 (2002), Category 6 and Category 7 components respectively. In reality it is a little more complicated even than this since there are different equations depending on whether the channel contains two, three or four connections.

So why are the new reference implementations so complex?

One reason is that the channel models are based upon what is termed the “component-up” approach and there is little or no difference between the channel performance requirements and what is delivered by the worst case (better known as minimally compliant) components. This renders previously ignored effects, such as temperature, much more important in the design process whereas the earlier editions of the standards contained a little “slop” in the models.

Another reason is that the introduction of the consolidation point and the resulting variable lengths of one or more of the channel components require a more detailed model. There are now minimum distances as well as maximum values and the maximum fixed horizontal cable length (PP-CP) depends upon the attenuation premiums of the cords which in turn depends upon whether they are of a stranded construction.

With such complex new reference implementations it would be natural to assume that using the correct components and following these rules would guarantee the correct channel performance. Unfortunately, that is where the “paradigm shift” has taken place.

What is this so-called “paradigm shift”?

The fundamental change is best summarised by the changes made to the “Conformance” clauses of the new standards. For the non-standards speaker, the Conformance clause defines what **has** to be achieved in order to assert that one has met the requirements of the standard.

The current published standards (ISO/IEC 11801 Ed1.2 and EN 50173 A1) state that the entire system shall be composed of links that meet the necessary level of performance. This shall be achieved by either using the correct components and link design (i.e. reference implementations) or by adopting an appropriate system design and implementation. This clearly emphasises the role of the implementation approach.

The final drafts of the second editions of these standards contain a significantly different statement. In these standards the performance of balanced cabling channels shall meet the specified requirements by one of the following approaches:

- a channel design and implementation ensuring that the prescribed channel is met;
- attachment of appropriate components to a permanent link or CP link design meeting the prescribed performance but that channel performance shall be assured where a channel is created by adding more than one cord to either end of a link;
- using reference implementations with compatible cabling components based upon a statistical approach of performance modelling.

Even the most cursory glance indicates that the issue of link and channel performance is now emphasised at the expense of the reference implementations.

However, the “devil is in the detail” and there are two sections of text that are new and very important. The first important message is contained in the second bullet point and is “*channel performance shall be assured where a channel is created by adding more than one cord to either end of a link*”. The second, from the third bullet, is provided by the text “*based upon a statistical approach of performance modelling*”.

Both of these are, in effect, cautionary statements regarding the guaranteed performance of channels based upon the component-up approach. The first means that even if a CP link is tested as compliant, the performance of the subsequent channel (created by the addition of a work area cord and a CP cable) is not guaranteed. Similarly, a conformant permanent link cannot be guaranteed to provide a compliant channel if a cross-connect panel is introduced at the distributor. The reference to the “*statistical approach of performance modelling*” is a further reference to the fact that minimally compliant components cannot be guaranteed to produce conformant channels in all cases.

The Cabling Partnership
P. O. Box MT 65, LEEDS, West Yorkshire, LS17 8YD, England
Telephone: +44 (0) 113 232 3721 Fax: +44 (0) 113 293 2632

The Cabling Partnership is a division of e-Ready Building Limited
Company Registration No. 4432595 Registered Office - Emery House, 192 Heaton Moor Road, Stockport, Cheshire, SK4 4DU.

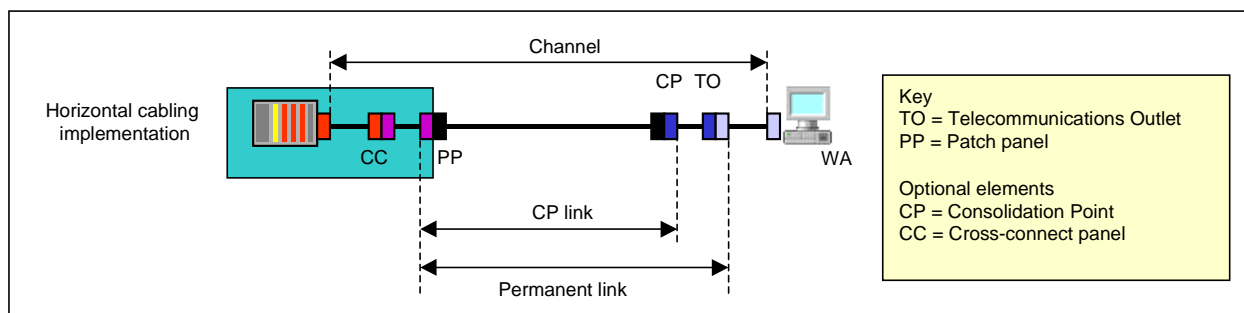

Good news for system suppliers

Obviously, there were at least two possible remedies that would have placed the reference implementation approach back into centre stage as before. One would have been to produce stiffer, or more stringent, specifications for the components. The other would have been to relax the permanent link and/or channel specifications. Neither of these was deemed acceptable by the supply side of the industry with the end result that designers, installers and users could be faced with complicated decisions regarding cabling supply.

The concept of mixing-and-matching of components is essentially sidelined by these issues. If an installer is contracted to install CP links and the user requires a guarantee of conformant channels then he/she is almost forced to pursue a system supplier guarantee.

A further issue is that of compatibility between balanced cabling plugs and sockets. An enormous amount of work has been undertaken in IEC (and in the US) in order to define the separate performance contribution of the plug and mating socket within the overall performance of a connection. This was necessary to enable a clear understanding of backwards compatibility (between different Categories) and interoperability (between different suppliers). This work has enabled, for the first time, the specification of patch cords. However, a detailed review of the work done uncovers the fact that electrical performance of connections is only guaranteed for their first mating (i.e. the guarantee expires after the initial connection). So, in truth, little has changed – manufacturers will be unlikely to guarantee universal interoperability and the system suppliers, once again, have the advantage.

Furthermore, the use of the term “statistical modelling” in the Conformance clause appears to allow installers to claim conformance even if test results appear to indicate a “FAIL”. The whole point of statistics is the impossibility to discriminate between true failures and statistical ones. Once again system suppliers may come to the rescue with zero tolerance policies regarding FAIL test results.

The installers viewpoint

Taking the last point first - no one likes FAIL results and even marginal pass outcomes are not desirable. Although this is not explicitly indicated in the forthcoming standards, it is known that the detailed modelling of channel performance indicates that the probability of channel failure increases as the number of segments within the channel increases. Therefore, four connection channels may be expected to produce more problems than two connection variants.

The statement that “*channel performance shall be assured where a channel is created by adding more than one cord to either end of a link*” adds further support for the widely held view that although cross-connect panels and consolidation points may be necessary from the user perspective they are, nonetheless, a source of technical concern and should be avoided wherever possible (unless underwritten by supplier guarantees).

The continued lack of standards-based guarantees of connection interoperability together with the more complex reference implementation rules suggest, once more, that installers need to provide users with clear guidance as to the applicable operating conditions and rules required to maintain the channel performance of their cabling infrastructures. This “User Guide” has been a particular cause-celebre of The Cabling Partnership for the last ten years and is clearly more important now than ever before.

The Cabling Partnership
P. O. Box MT 65, LEEDS, West Yorkshire, LS17 8YD, England
Telephone: +44 (0) 113 232 3721 Fax: +44 (0) 113 293 2632

The Cabling Partnership is a division of e-Ready Building Limited
Company Registration No. 4432595 Registered Office - Emery House, 192 Heaton Moor Road, Stockport, Cheshire, SK4 4DU.